

12060 FORD ESCAPE / MAZDA TRIBUTE / MERCURY MARINER

GROSS LOAD CAPACITY WHEN USED AS A WEIGHT CARRYING HITCH: 3,500 LBS. TRAILER WEIGHT & 350 LBS. TONGUE WEIGHT.

DO NOT EXCEED VEHICLE MANUFACTURER'S RECOMMENDED TOWING CAPACITY.

WARNING: ALL NON-TRAILER LOADS APPLIED TO THIS PRODUCT MUST BE SUPPORTED BY 18050 STABILIZING STRAPS.

** FAILURE TO PROPERLY SUPPORT NON-TRAILER LOADS WILL VOID PRODUCT WARRANTY**

Parts List			
ITEM	QTY	PART NUMBER	DESCRIPTION
1	1	CM-SP43	.375 x 1.25 x 2.50" SQUARE HOLE SPACER
2	6	1/2-13 x 1 3/4	CARRIAGE BOLT
3	6	CM-SP6	.250 x 1.00 x 3.00" SQUARE HOLE SPACER
4	6	1/2"	CONICAL TOOTHED WASHER
5	6	1/2-13	HEX NUT
6	2	1_2 FISHWIRE	1/2" FISHWIRE

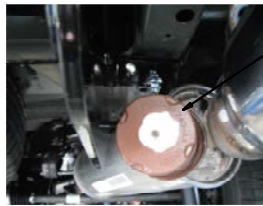

EXHAUST DAMPENER

PASSENGER SIDE FRAME RAIL

FISHWIRE TECHNIQUE
 INSERT COILED END OF FISHWIRE TOOL THROUGH HITCH MOUNTING HOLE IN VEHICLE FRAME RAIL AND OUT THE ACCESS HOLE. PASS COILED END OF FISHWIRE THROUGH SPACER AND THREAD BOLT INTO COIL. KINK WIRE TO KEEP SPACER SEPERATE FROM BOLT AS SHOWN. PULL FISHWIRE, SPACER, AND BOLT THROUGH FRAME AND OUT MOUNTING HOLE. USE FISHWIRE TO GUIDE HITCH DURING MOUNTING AND PREVENT LOSS OF BOLT / SPACER INSIDE FRAME RAIL.
NOTE: SOME VEHICLES MAY FISHWIRE THROUGH END OF FRAME

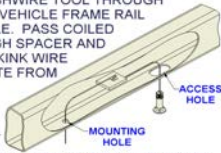

TOOLS REQUIRED	
RATCHET	
3/4" SOCKET	
TORQUE WRENCH	
DIE GRINDER w/ CARBIDE BIT	

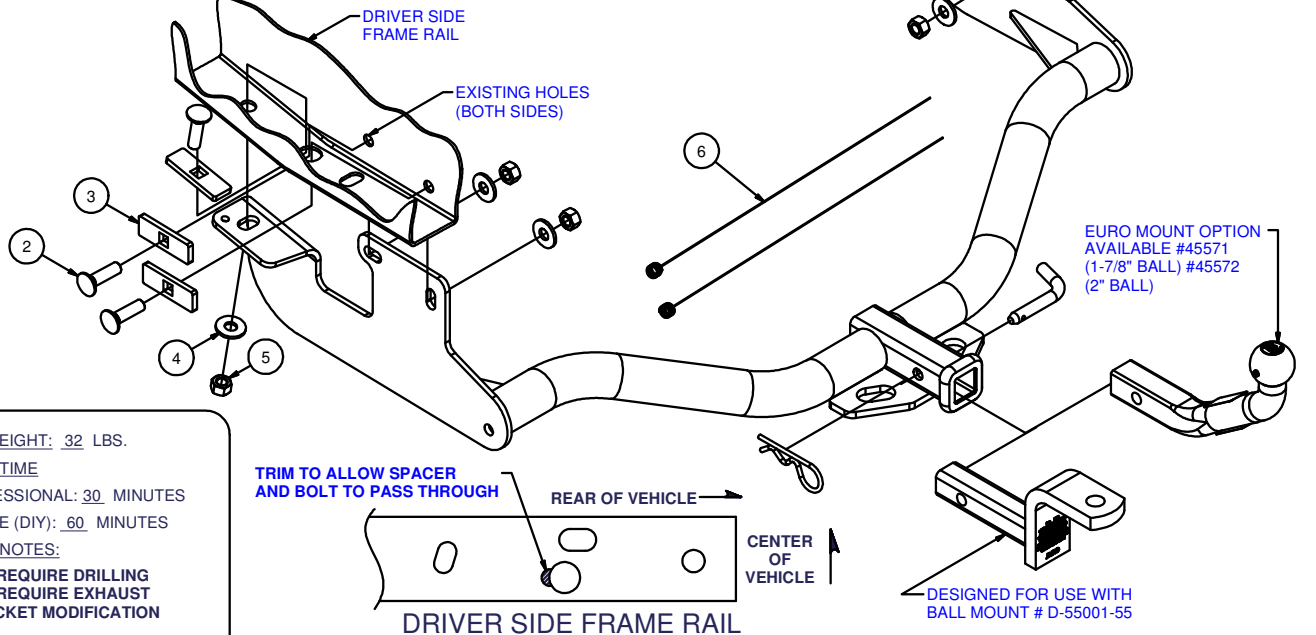

HITCH WEIGHT: .32 LBS.

INSTALL TIME

PROFESSIONAL: .30 MINUTES

NOVICE (DIY): .60 MINUTES

INSTALL NOTES:

- MAY REQUIRE DRILLING
- MAY REQUIRE EXHAUST BRACKET MODIFICATION

INSTALLATION STEPS

NOTES: If there is access to put the bolt and spacer into the frame rail from end there is no need to drill. Some vehicles have different tie down hooks that allow access to frame rail ends.

- If your vehicle is equipped with an exhaust vibration dampener and interferes with the side plate, bend or pry the the dampener away from the side plate as needed.

- 1) Using fishwire, pull carriage bolts and square hole spacers through holes in bottom of frame rail (may require drilling an access hole in frame).
- 2) Place spacer on passenger side bolt and raise hitch into position. Hand tighten the fasteners.
- 3) Fishwire the remaining fasteners into position and secure with conical tooth washers and hex nuts as shown.
- 4) Torque all 1/2" fasteners to 110 lb-ft.

PERIODICALLY CHECK THIS RECEIVER HITCH TO ENSURE THAT ALL FASTENERS ARE TIGHT AND THAT ALL STRUCTURAL COMPONENTS ARE SOUND.



The **FIRST** Name in Towing Products™

Trailer Hitches