

12051 CHEVROLET MALIBU LS, LT & LTZ / SATURN AURA

GROSS LOAD CAPACITY WHEN USED AS A WEIGHT CARRYING HITCH: 3500 LBS. TRAILER WEIGHT & 300 LBS. TONGUE WEIGHT.
*****DO NOT EXCEED VEHICLE MANUFACTURER'S RECOMMENDED TOWING CAPACITY.*****

Parts List			
ITEM	QTY	PART NUMBER	DESCRIPTION
1	2	1/2-13 x 1 3/4	CARRIAGE BOLT
2	2	CM-SP6	.250 x 1.00 x 3.00" SQUARE HOLE SPACER
3	2	HFN 1213	HEX FLANGE NUT
4	2	3/8-16 x 1 1/2	CARRIAGE BOLT
5	2	CM-SP18	.250 x 1.00 x 2.00" SQUARE HOLE SPACER
6	2	CM-SP50	.250 x 1.00 x 1.50" ROUND HOLE SPACER
7	2	HFN3816	HEX FLANGE NUT
8	2	3_8 FISHWIRE	3/8" FISHWIRE
9	2	1_2 FISHWIRE	1/2" FISHWIRE

TOOLS REQUIRED	
DRILL	
17/32" DRILL BIT	
9/16" SOCKET	
3/4" SOCKET	
RATCHET	
TORQUE WRENCH	
BLACK SHARPIE	

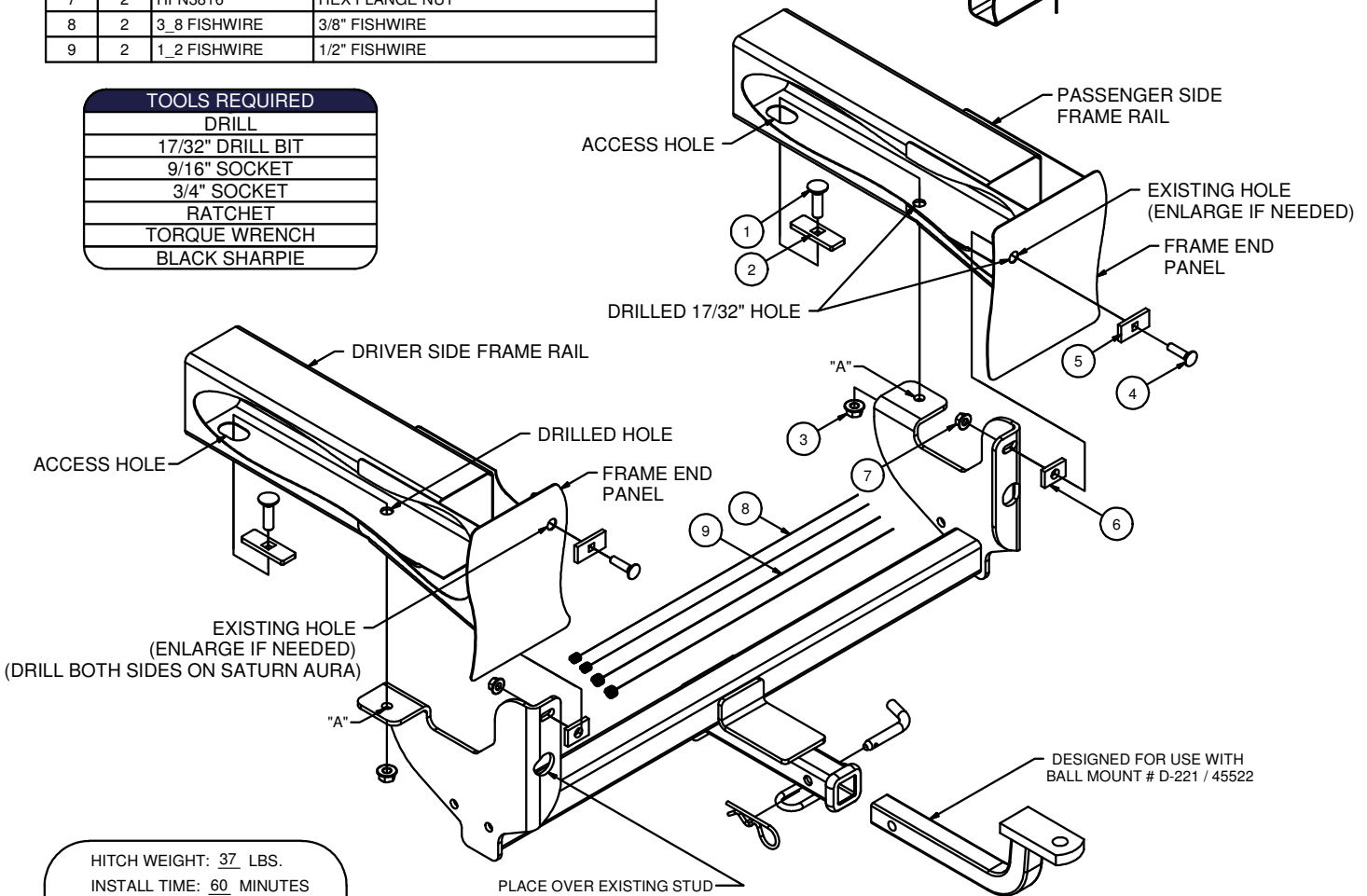

HITCH WEIGHT: 37 LBS.
 INSTALL TIME: 60 MINUTES

INSTALL NOTES:
 - DRILLING REQUIRED
 - FISHWIRE HARDWARE

- Vehicle needs to be jacked up if installation is from ground level.
 - On models with dual exhaust, lower the exhaust to ease installation.

INSTALLATION STEPS

1. Feed fishwire through end panel. Slide spacer (Item 5) onto fishwire then thread carriage bolt (Item 4) onto fishwire. Gently pull spacer plate and carriage bolt into position. Thread spacer (Item 6) onto fishwire. Leave fishwire attached to carriage bolt to hold parts in position.
2. Raise the hitch into position and secure with hex flange nuts (Item 7).
3. Using the hitch as a template, drill one 17/32" hole thru each frame rail as shown.
4. Feed the fishwire through the hole in the hitch side plate ("A"), the drilled hole in frame rail and out the access hole in the frame rail.
5. Thread spacer (Item 2) onto fishwire, attach to carriage bolt (Item 1). Pull fasteners through slot & into position as shown.
6. Loosely install hex flange nuts (Item 3) onto carriage bolts.
7. Torque all 3/8" fasteners to 45 lb-ft and torque all 1/2" fasteners to 110 lb-ft.

PERIODICALLY CHECK THIS RECEIVER HITCH TO ENSURE THAT ALL FASTENERS ARE TIGHT AND THAT ALL STRUCTURAL COMPONENTS ARE SOUND.



The **FIRST** Name
 in Towing Products™

Trailer Hitches