



12031 INSTALLATION INSTRUCTIONS

YEARS: 1999-PRESENT

MAKE: HONDA

MODEL: ODYSSEY

STYLE: VAN





WARNING: NEVER EXCEED YOUR VEHICLE MANUFACTURER'S RECOMMENDED TOWING CAPACITY

WEIGHT CARRYING:
 TRAILER WEIGHT: 3,500 LBS.
 TONGUE WEIGHT: 350 LBS.

INSTALLATION TIME: 20 MIN.

THE INSTALL TIME LISTED IS FOR PROFESSIONAL INSTALLERS. IF YOU ARE HESITANT TO UNDERTAKE THIS TASK ON YOUR OWN, CONTACT AN AUTHORIZED CURT INSTALLER FOR ADDITIONAL ASSISTANCE.



INSTALLATION REQUIRES:

 RATCHET	 TORQUE WRENCH	 9" SOCKET EXTENSION
 11/16" 19mm 10mm SOCKET	 SCREW DRIVER	

INSTALLATION TIPS:

- BEFORE YOU BEGIN INSTALLATION, READ ALL INSTRUCTIONS THOROUGHLY.
- TO EASE INSTALLATION, 2 PEOPLE MAY BE REQUIRED.
- USING PROPER TOOLS WILL GREATLY IMPROVE THE QUALITY OF THE INSTALL AND REDUCE THE TIME REQUIRED.
- NEED HELP OR HAVE SOME QUESTIONS? CALL TECHNICAL SUPPORT AT 800.798.0813

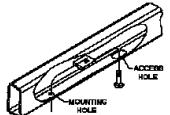
LEVEL OF DIFFICULTY: EASY

EASY	MODERATE	HARD
	- NO DRILLING REQUIRED	
	- FISHWIRE HARDWARE	
	- DRIVER SIDE COVER REMOVAL IF PRESENT	

VEHICLE PHOTO:



REPRESENTATIVE PHOTO

TRAILER HITCH ILLUSTRATION:

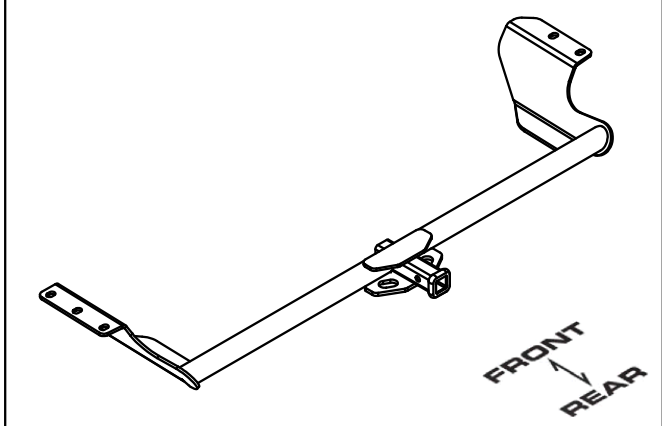

MAKE SURE YOUR HITCH MATCHES

PERIODICALLY CHECK THIS RECEIVER HITCH TO ENSURE ALL FASTENERS ARE TIGHT AND ALL STRUCTURAL COMPONENTS ARE SOUND
 CURT Manufacturing Inc. warrants this product to be free of defects in material and/or workmanship at the time of retail purchase by the original purchaser. If the product is found to be defective, Curt Manufacturing Inc. may repair or replace the product at their option, when the product is returned, prepaid, with proof of purchase. Alteration to, misuse of, or improper installation of this product voids the warranty. Curt Manufacturing Inc.'s liability is limited to repair or replacement of products found to be defective, and specifically excludes liability for incidental or consequential loss or damage.

INSTALLATION WALKTHROUGH:

Parts List			
ITEM	QTY	PART NUMBER	DESCRIPTION
1	4	M12-1.25 x 35mm	HEX BOLT
2	4	1/2"	CONICAL TOOTHED WASHER
3	1	7/16-14	HEX FLANGE NUT
4	1	CM-SP2	.250 x .88 x 2.25" SQUARE HOLE SPACER
5	1	7/16-14 x 1 1/2	CARRIAGE BOLT
6	1	7_16 FISHWIRE	7/16" FISHWIRE

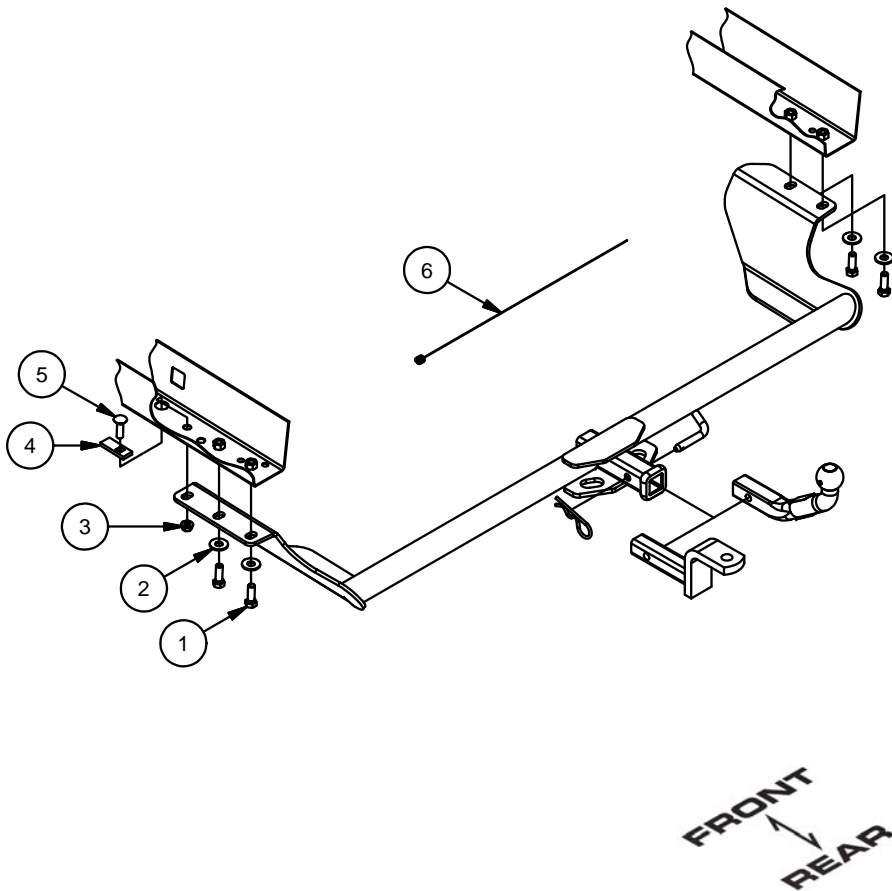

1. If present, remove (5) fasteners and the plastic fascia covering the driver side frame rail. Return fasteners and plastic fascia to owner. **Note:** You may trim fascia and re-attach after hitch installation.



2. Locate (2) weldnuts near the end of each frame rail. Clean weldnuts of debris and rust to ease hitch installation.

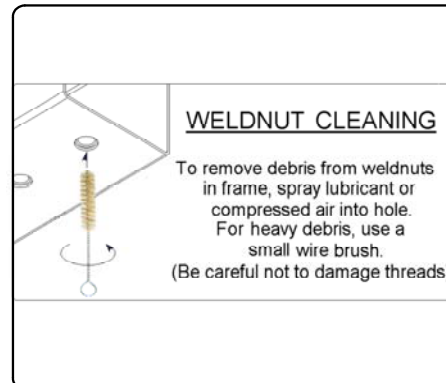

INSTALLATION WALKTHROUGH:

3. Raise hitch into position by sliding the passenger side plate over the exhaust first. Secure the hitch into position using M12-1.25 x 35mm bolts and 1/2" conical toothed washers.

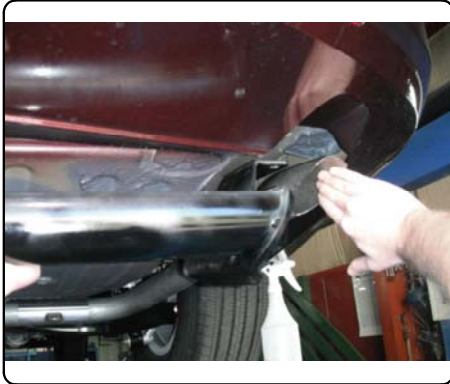

4. On the driver side frame rail fishwire a 7/16-14 x 1 1/2" carriage bolt and CM-SP2 spacer through the access hole and into the existing hole in the bottom of the frame rail. Secure with 7/16" flange nut.

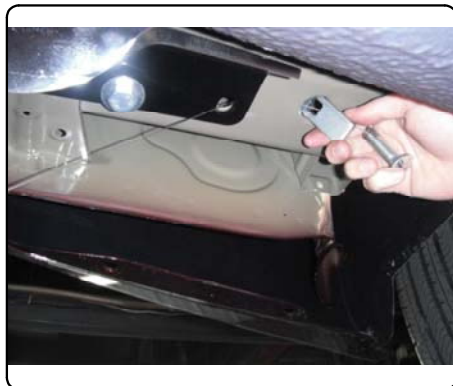
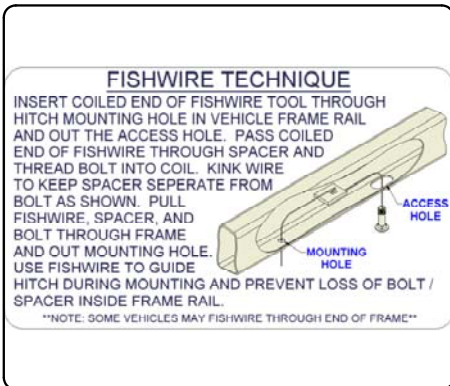

5. Torque all 12mm hardware to 11 ft-lbs.
Torque all 7/16" hardware to 10 ft-lbs.



Install is complete

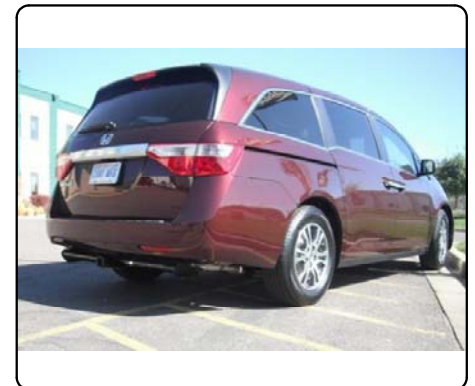

12031

HONDA ODYSSEY

9/21/2012

GROSS LOAD CAPACITY WHEN USED AS A WEIGHT CARRYING HITCH: 3,500 LBS. TRAILER WEIGHT & 350 LBS. TONGUE WEIGHT.

DO NOT EXCEED VEHICLE MANUFACTURER'S RECOMMENDED TOWING CAPACITY.

WARNING: ALL NON-TRAILER LOADS APPLIED TO THIS PRODUCT MUST BE SUPPORTED BY 18050 STABILIZING STRAPS.

** FAILURE TO PROPERLY SUPPORT NON-TRAILER LOADS WILL VOID PRODUCT WARRANTY**

Parts List			
ITEM	QTY	PART NUMBER	DESCRIPTION
1	4	M12-1.25 x 35mm	HEX BOLT
2	4	1/2"	CONICAL TOOTHED WASHER
3	1	7/16-14	HEX FLANGE NUT
4	1	CM-SP2	.250 x .88 x 2.25" SQUARE HOLE SPACER
5	1	7/16-14 x 1 1/2	CARRIAGE BOLT
6	1	7_16 FISHWIRE	7/16" FISHWIRE

FISHWIRE TECHNIQUE

INSERT COILED END OF FISHWIRE TOOL THROUGH HITCH MOUNTING HOLE IN VEHICLE FRAME RAIL AND OUT THE ACCESS HOLE. PASS COILED END OF FISHWIRE THROUGH SPACER AND THREAD BOLT INTO COIL. KINK WIRE TO KEEP SPACER SEPARATE FROM BOLT AS SHOWN. PULL FISHWIRE, SPACER, AND BOLT THROUGH FRAME AND OUT MOUNTING HOLE. USE FISHWIRE TO GUIDE HITCH DURING MOUNTING AND PREVENT LOSS OF BOLT / SPACER INSIDE FRAME RAIL.

"NOTE: SOME VEHICLES MAY FISHWIRE THROUGH END OF FRAME"

WELDNUT CLEANING

To remove debris from weldnuts in frame, spray lubricant or compressed air into hole. For heavy debris, use a small wire brush. (Be careful not to damage threads).

TOOLS REQUIRED

RATCHET
TORQUE WRENCH
9" EXTENSION
11/16" SOCKET
19mm SOCKET
10mm SOCKET
SCREWDRIVER

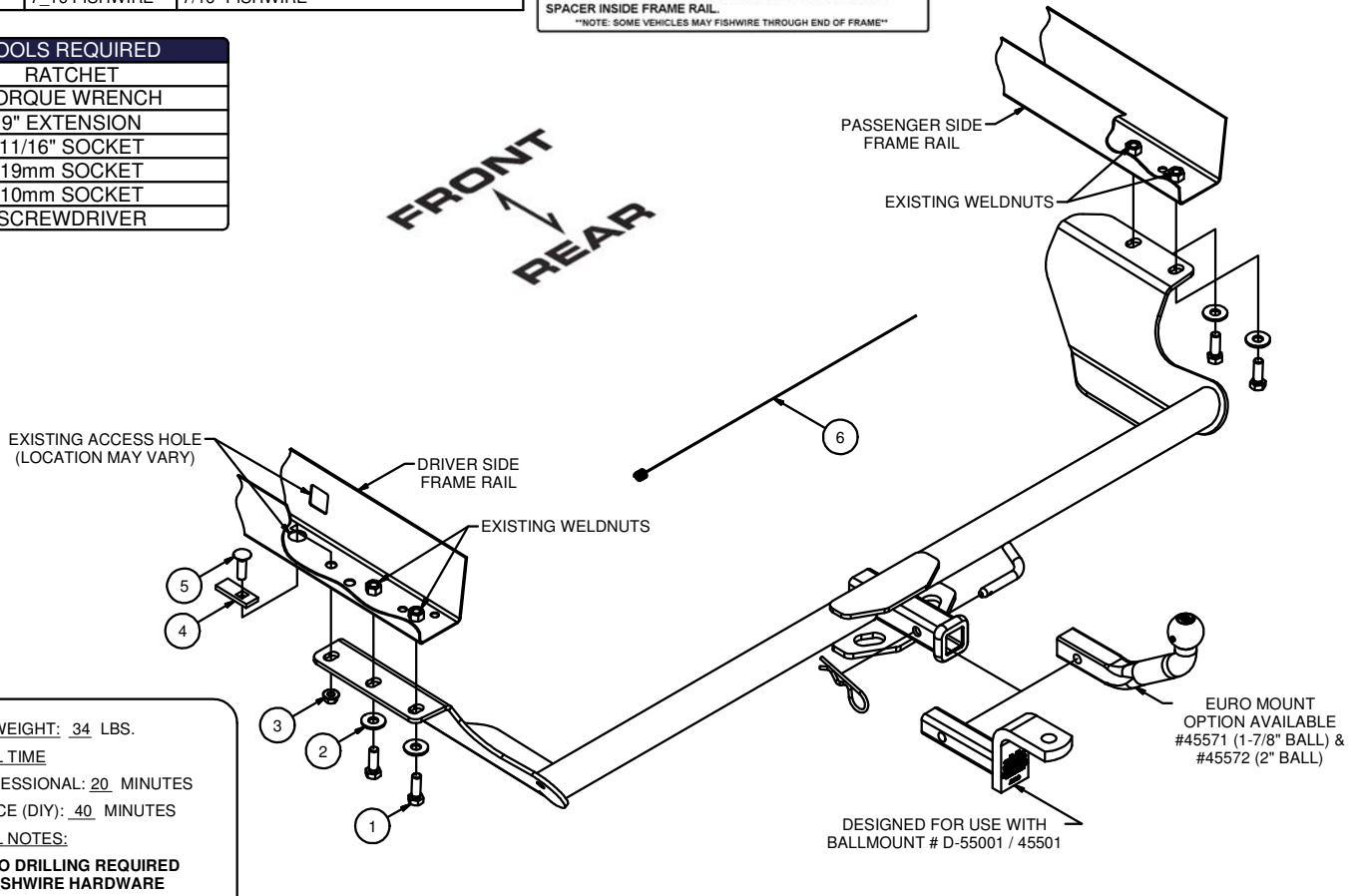

HITCH WEIGHT: 34 LBS.

INSTALL TIME

PROFESSIONAL: 20 MINUTES

NOVICE (DIY): 40 MINUTES

INSTALL NOTES:

- NO DRILLING REQUIRED
- FISHWIRE HARDWARE

INSTALLATION STEPS

1. If present, remove (5) fasteners and the plastic fascia covering the driver side frame rail. Return fasteners and plastic shield to owner. **Note:** You may trim fascia and re-attach after hitch installation.
2. Locate (2) weldnuts near the end of each frame rail. Clean weldnuts of debris and rust to ease hitch installation. (See weldnut cleaning)
3. Raise hitch into position by sliding the passenger side plate over the exhaust first. Secure the hitch into position using M12-1.25 x 35mm bolts and 1/2" conical toothed washers.
4. On the driver side frame rail fishwire a 7/16-14 x 1 1/2" carriage bolt and CM-SP2 spacer through the access hole and into the existing hole in the bottom of the frame rail. Secure with 7/16" flange nut. (See fishwire technique)
5. Torque all 12mm hardware to 86 ft-lbs.
Torque all 7/16" hardware to 70 ft-lbs.

PERIODICALLY CHECK THIS RECEIVER HITCH TO ENSURE THAT ALL FASTENERS ARE TIGHT AND THAT ALL STRUCTURAL COMPONENTS ARE SOUND.

Curt Manufacturing Inc., warrants this product to be free of defects in material and/or workmanship at the time of retail purchase by the original purchaser. If the product is found to be defective, Curt Manufacturing Inc., may repair or replace the product, at their option, when the product is returned, prepaid, with proof of purchase. Alteration to, misuse of, or improper installation of this product voids the warranty. Curt Manufacturing Inc.'s liability is limited to repair or replacement of products found to be defective, and specifically excludes liability for incidental or consequential loss or damage.