

12002

SUZUKI GRAND VITARA

GROSS LOAD CAPACITY WHEN USED AS A WEIGHT CARRYING HITCH: 3,500 LBS. TRAILER WEIGHT & 350 LBS. TONGUE WEIGHT.

\*\*\*DO NOT EXCEED VEHICLE MANUFACTURER'S RECOMMENDED TOWING CAPACITY.\*\*\*

WARNING: ALL NON-TRAILER LOADS APPLIED TO THIS PRODUCT MUST BE SUPPORTED BY 18050 STABILIZING STRAPS.

\*\* FAILURE TO PROPERLY SUPPORT NON-TRAILER LOADS WILL VOID PRODUCT WARRANTY\*\*

Parts List			
ITEM	QTY	PART NUMBER	DESCRIPTION
1	6	M12-1.25 x 35mm	HEX BOLT
2	6	1/2"	CONICAL TOOTHED WASHER

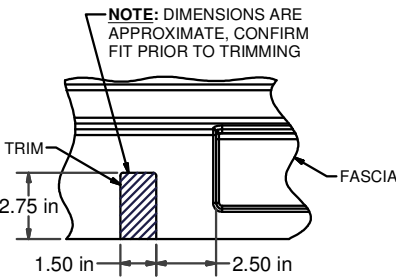
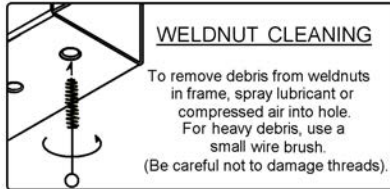
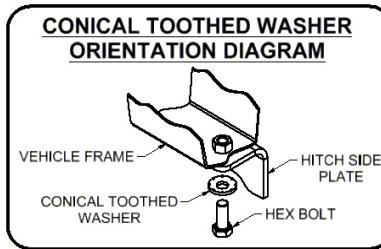

TOOLS REQUIRED
RATCHET
17mm SOCKET
19mm SOCKET
12" SOCKET EXTENSION
TORQUE WRENCH
ROTARY TOOL

HITCH WEIGHT: .39 LBS.  
 INSTALL TIME  
 PROFESSIONAL: 30 MINUTES  
 NOVICE (DIY): 60 MINUTES  
 INSTALL NOTES:  
 - REMOVE TOW HOOK  
 - NO DRILLING REQUIRED  
 - FASCIA TRIMMING (SOME MODELS)

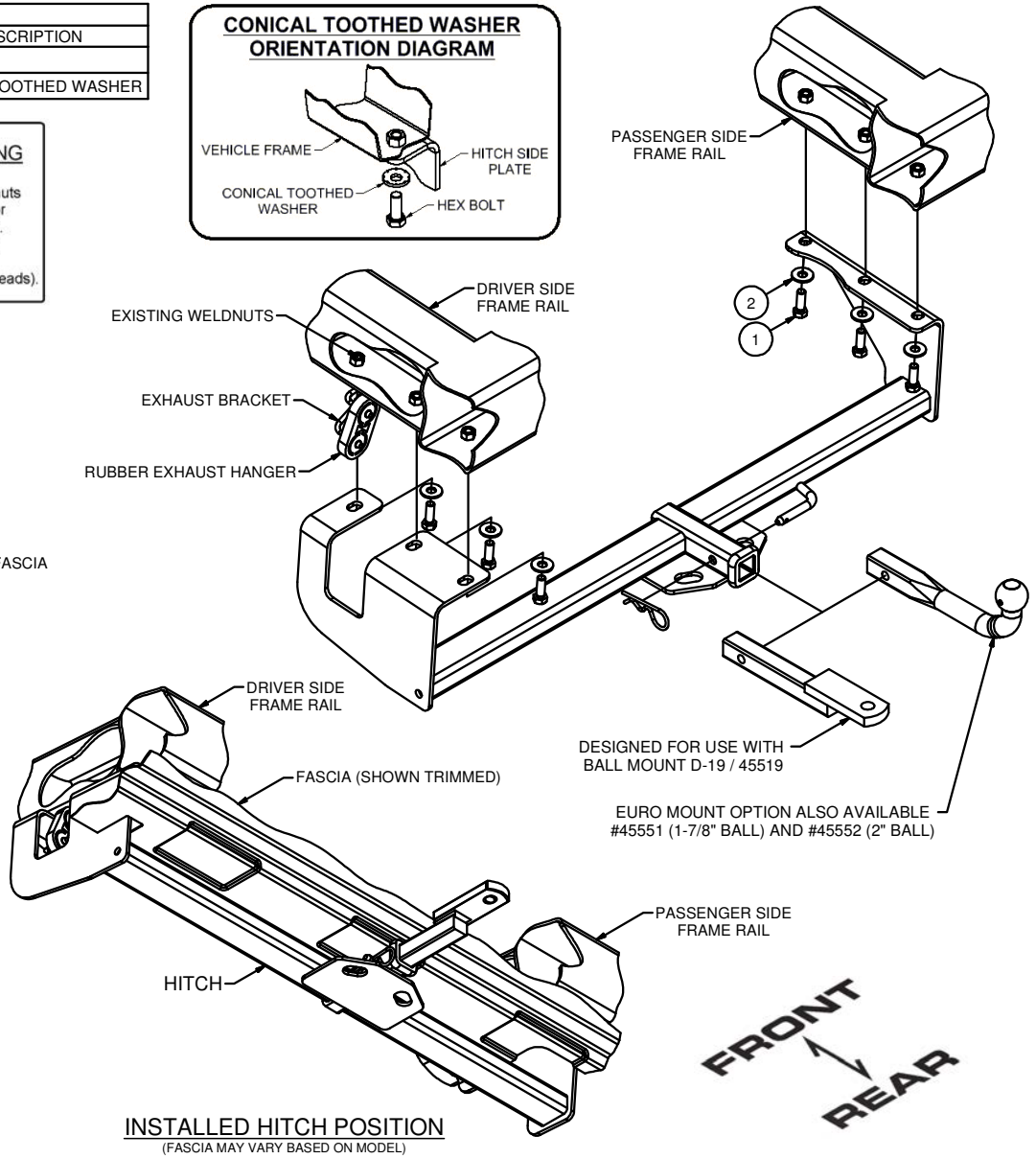

**INSTALLED HITCH POSITION**  
 (FASCIA MAY VARY BASED ON MODEL)

**INSTALLATION STEPS**

**NOTE:** If hatch-mounted spare is not present you will have to trim the rear fascia. (See Trim Diagram)

1. Remove tow hook and return to owner.
2. Raise hitch into position, driver side plate should be positioned outside of exhaust hanger.
3. Install supplied fasteners into existing frame weldnuts.
4. Torque all 12 MM fasteners to 86 ft-lbs.

**PERIODICALLY CHECK THIS RECEIVER HITCH TO ENSURE THAT ALL FASTENERS ARE TIGHT AND THAT ALL STRUCTURAL COMPONENTS ARE SOUND.**



The **FIRST** Name in Towing Products™

Trailer Hitches