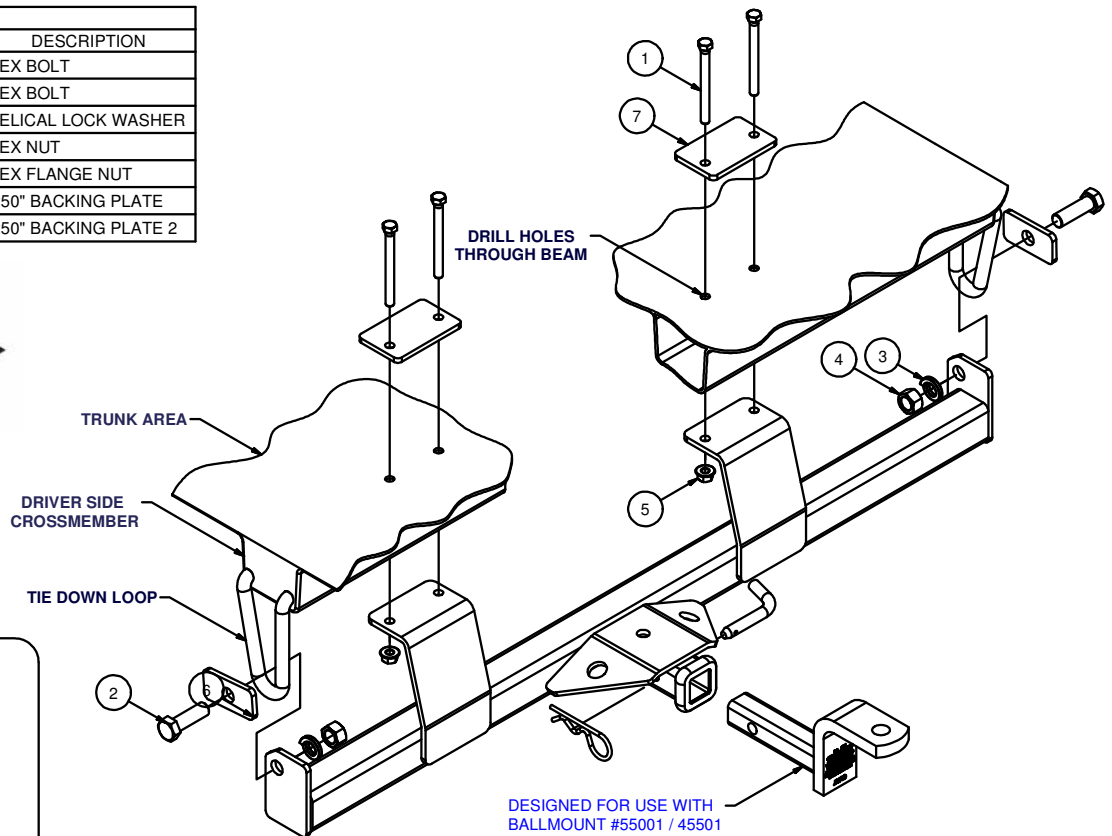

11804**88-91 MAZDA 929 SEDAN****3/27/2013****GROSS LOAD CAPACITY WHEN USED AS A WEIGHT CARRYING HITCH: 2,500 LBS. TRAILER WEIGHT & 200 LBS. TONGUE WEIGHT.*******DO NOT EXCEED VEHICLE MANUFACTURER'S RECOMMENDED TOWING CAPACITY.*******WARNING: ALL NON-TRAILER LOADS APPLIED TO THIS PRODUCT MUST BE SUPPORTED BY 18050 STABILIZING STRAPS.****** FAILURE TO PROPERLY SUPPORT NON-TRAILER LOADS WILL VOID PRODUCT WARRANTY****

Parts List			
ITEM	QTY	PART NUMBER	DESCRIPTION
1	4	3/8 - 16 x 4	HEX BOLT
2	2	5/8 - 11 x 2 HEX	HEX BOLT
3	2	5/8 LOCK WASHER	HELICAL LOCK WASHER
4	2	5/8 - 11 HEX-NUT	HEX NUT
5	4	HFN3816	HEX FLANGE NUT
6	2	CM-11804-BP	.250" BACKING PLATE
7	2	CM-11804-BP2	.250" BACKING PLATE 2

FRONT
↕
REAR

HITCH WEIGHT: 31 LBS.**INSTALL TIME**PROFESSIONAL: 45 MINUTESNOVICE (DIY): 90 MINUTES**INSTALL NOTES:**

- CLEAR TRUNK CONTENTS
- DRILLING REQUIRED
- SILICONE FASTENERS

INSTALLATION STEPS

1. Clear the vehicle's trunk area for drilling. Place the hitch on the vehicle between the tie down loops (under the rear of the vehicle on both sides) with hitch brackets placed against the crossmember. Adjust the hitch to be level and place fasteners temporarily in place.
2. Mark the crossmember for (2) holes in each floor bracket. Remove the hitch from the vehicle. Centerpunch and drill the crossmember (4) places for 3/8" bolts. Drill through (2) surfaces into the trunk area, drilling STRAIGHT up.
3. Reinstall hitch on the vehicle. Install fasteners from inside the trunk using (1) CM-11804-BP2 reinforcement plate in the trunk above each floor bracket. Tighten fasteners (lock nuts used) snug without crushing the crossmember.
4. Fasten the hitch at the tie down loops using fasteners as shown. Loops are sandwiched between the hitch and separate CM-11804-BP backing plates.
5. Torque all 3/8" fasteners to 45 lb-ft, and all 5/8" fasteners to 210 lb-ft.
6. Apply silicone sealant around fasteners installed in the trunk to seal out water and exhaust fumes.
7. Reinstall contents of trunk removed in step 1.

PERIODICALLY CHECK THIS RECEIVER HITCH TO ENSURE THAT ALL FASTENERS ARE TIGHT AND THAT ALL STRUCTURAL COMPONENTS ARE SOUND.



The **FIRST** Name
in Towing Products™

Trailer Hitches