

11801

90-96 INFINITI Q45 SEDAN

GROSS LOAD CAPACITY WHEN USED AS A WEIGHT CARRYING HITCH: 2,500 LBS. TRAILER WEIGHT & 200 LBS. TONGUE WEIGHT.

DO NOT EXCEED VEHICLE MANUFACTURER'S RECOMMENDED TOWING CAPACITY.

WARNING: ALL NON-TRAILER LOADS APPLIED TO THIS PRODUCT MUST BE SUPPORTED BY AUXILIARY STABILIZING STRAPS.

** FAILURE TO PROPERLY SUPPORT NON-TRAILER LOADS WILL VOID PRODUCT WARRANTY**

Parts List			
ITEM	QTY	PART NUMBER	DESCRIPTION
1	1	CM-438-FW	7/16" FISHWIRE TOOL
2	3	7/16 LOCK WASHER	HELICAL LOCK WASHER
3	2	M10 - 1.25 x 30	HEX BOLT
4	2	3/8"	WASHER
5	1	5_8 - 11 x 2 HEX	HEX BOLT
6	1	5/8	WASHER
7	1	5_8 LOCK WASHER	HELICAL LOCK WASHER
8	1	5_8 - 11 HEX-NUT	HEX NUT
9	1	7/16-14 x 1 1/2	CARRIAGE BOLT
10	1	7/16-14	HEX NUT
11	1	CM-SP40	.188 x 1.00 x 3.00" SQUARE HOLE SPACER

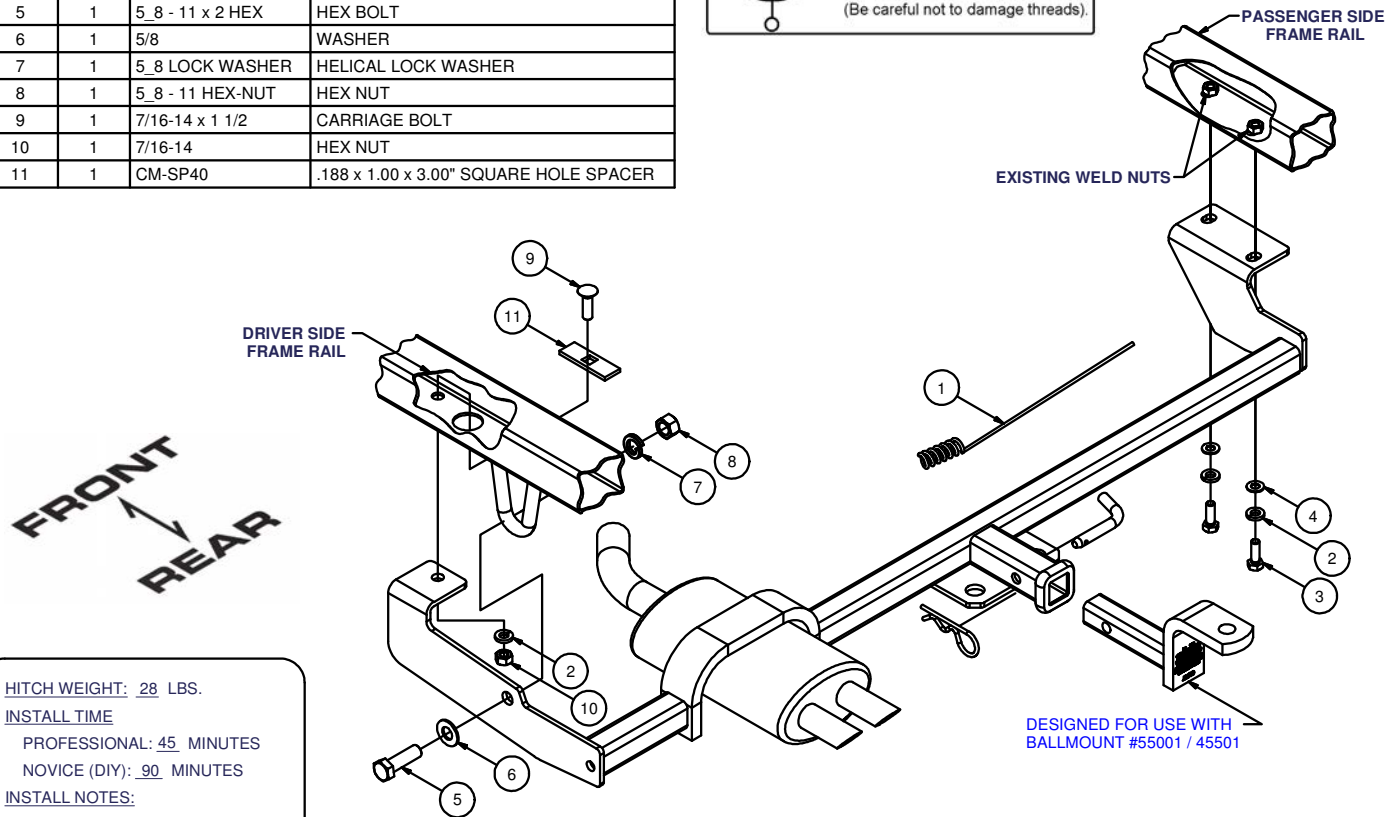
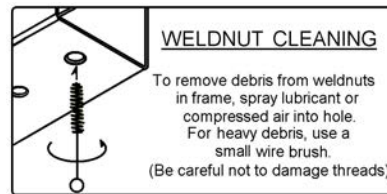

HITCH WEIGHT: 28 LBS.

INSTALL TIME

PROFESSIONAL: 45 MINUTES

NOVICE (DIY): 90 MINUTES

INSTALL NOTES:

- DRILLING REQUIRED
- REMOVE TIE DOWN BRACKET

INSTALLATION STEPS

- Under the rear of the car on the driver's side, locate (do not remove) the tie down loop outside the muffler. On the passenger side of the car, locate and remove the tie down bracket from the frame rail with three 10mm screws. Return these parts to the car's owner for reinstallation should the hitch ever be removed.
- Position the hitch on the car with the U-shaped exhaust bridge passing over the exhaust tips. The left side bracket will fit outside the tie down loop, with the bracket hole aligned with the loop. The passenger side hitch bracket will bolt directly to the bottom at two 10mm threaded holes in the frame as shown.
- With the hitch in final position, drill one 1/2" hole in the driver side frame rail, through the hitch bracket. Lower the hitch and fishwire the carriage bolt and backing plate into position using existing access hole.
- Reposition the hitch on the car, placing the driver side hitch bracket over the 7/16" carriage bolt.
NOTE: A metal panel may have to be trimmed slightly on the driver side to position the fasteners.
- Torque all 10mm fasteners to 48 lb-ft, all 7/16" fasteners to 70 lb-ft, and all 5/8" fasteners to 210 lb-ft.

PERIODICALLY CHECK THIS RECEIVER HITCH TO ENSURE THAT ALL FASTENERS ARE TIGHT AND THAT ALL STRUCTURAL COMPONENTS ARE SOUND.



The **FIRST** Name
in Towing Products™

Trailer Hitches