

11749 / 247314**98-05 MAZDA MIATA CONVERTIBLE**

10/15/2012

GROSS LOAD CAPACITY WHEN USED AS A WEIGHT CARRYING HITCH: 2,000 LBS. TRAILER WEIGHT & 200 LBS. TONGUE WEIGHT.
*****DO NOT EXCEED VEHICLE MANUFACTURER'S RECOMMENDED TOWING CAPACITY.*****

Parts List			
ITEM	QTY	PART NUMBER	DESCRIPTION
1	4	7/16-14 x 1 1/4	HEX BOLT
2	4	7/16 LOCK WASHER	HELICAL LOCK WASHER
3	4	7_16-14 TAB NUT	HANDLE NUT

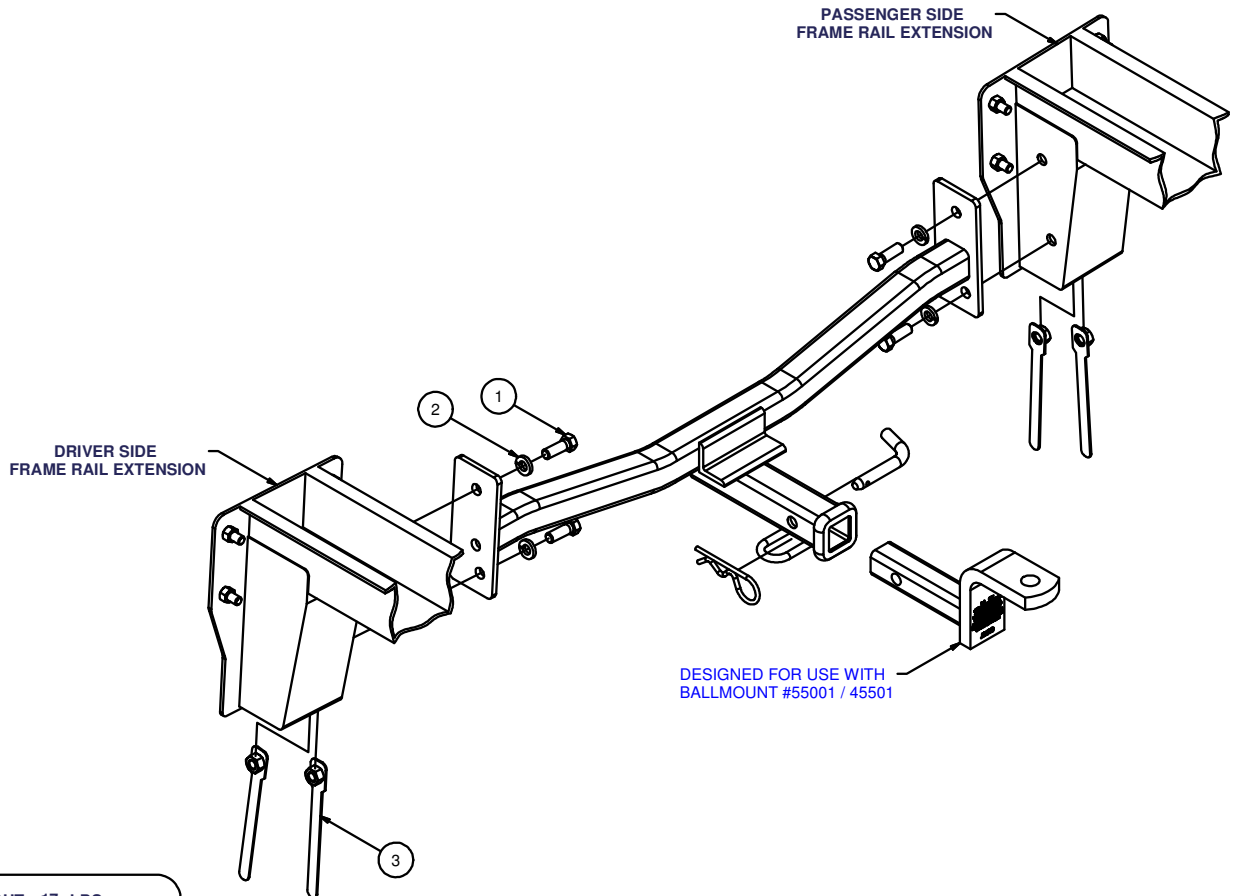

HITCH WEIGHT: 17 LBS.
 INSTALL TIME: 30 MINUTES
 INSTALL NOTES:
 DRILLING REQUIRED

INSTALLATION STEPS

- 1) This hitch mounts to the inside surface of the left and right frame rail extensions.
- 2) Position the hitch up between the frame rail extensions, with the hitch plates as far rearward as possible and flush at the bottom surface of the frame rail extensions. Using the hitch as a template, mark the centers of the holes to be drilled for fasteners as shown.
- 3) Remove the hitch and drill for fasteners.
- 4) Position the hitch on the vehicle matching the holes in the frame rail extensions with the holes in the hitch plates. Install fasteners as shown. Pass handle nuts up through the opening at the bottom of the frame rails extensions.
- 5) Torque all 7/16 fasteners to 70 lb-ft.

PERIODICALLY CHECK THIS RECEIVER HITCH TO ENSURE THAT ALL FASTENERS ARE TIGHT AND THAT ALL STRUCTURAL COMPONENTS ARE SOUND.



The **FIRST** Name
in Towing Products™

Trailer Hitches