

11728

93-95 MITSUBISHI DIAMANTE WAGON

3/25/2013

GROSS LOAD CAPACITY WHEN USED AS A WEIGHT CARRYING HITCH: 2,000 LBS. TRAILER WEIGHT & 200 LBS. TONGUE WEIGHT.

*****DO NOT EXCEED VEHICLE MANUFACTURER'S RECOMMENDED TOWING CAPACITY.*****

WARNING: ALL NON-TRAILER LOADS APPLIED TO THIS PRODUCT MUST BE SUPPORTED BY 18050 STABILIZING STRAPS.

**** FAILURE TO PROPERLY SUPPORT NON-TRAILER LOADS WILL VOID PRODUCT WARRANTY****

| Parts List | | | | |
|------------|-----|----------------|---------------------------------------|--|
| ITEM | QTY | PART NUMBER | DESCRIPTION | |
| 1 | 6 | 3/8-16 X 1 1/2 | HEX BOLT | |
| 2 | 2 | CM-3810-UBR | 3/8 DIA. x 2.00 WIDE x 3.00 LG U-BOLT | |
| 3 | 4 | 3/8" | FENDER WASHER | |
| 4 | 10 | HFN3816 | HEX FLANGE NUT | |
| 5 | 1 | CM-11728-SB | .50 x 1.25 SUB BUMPER | |

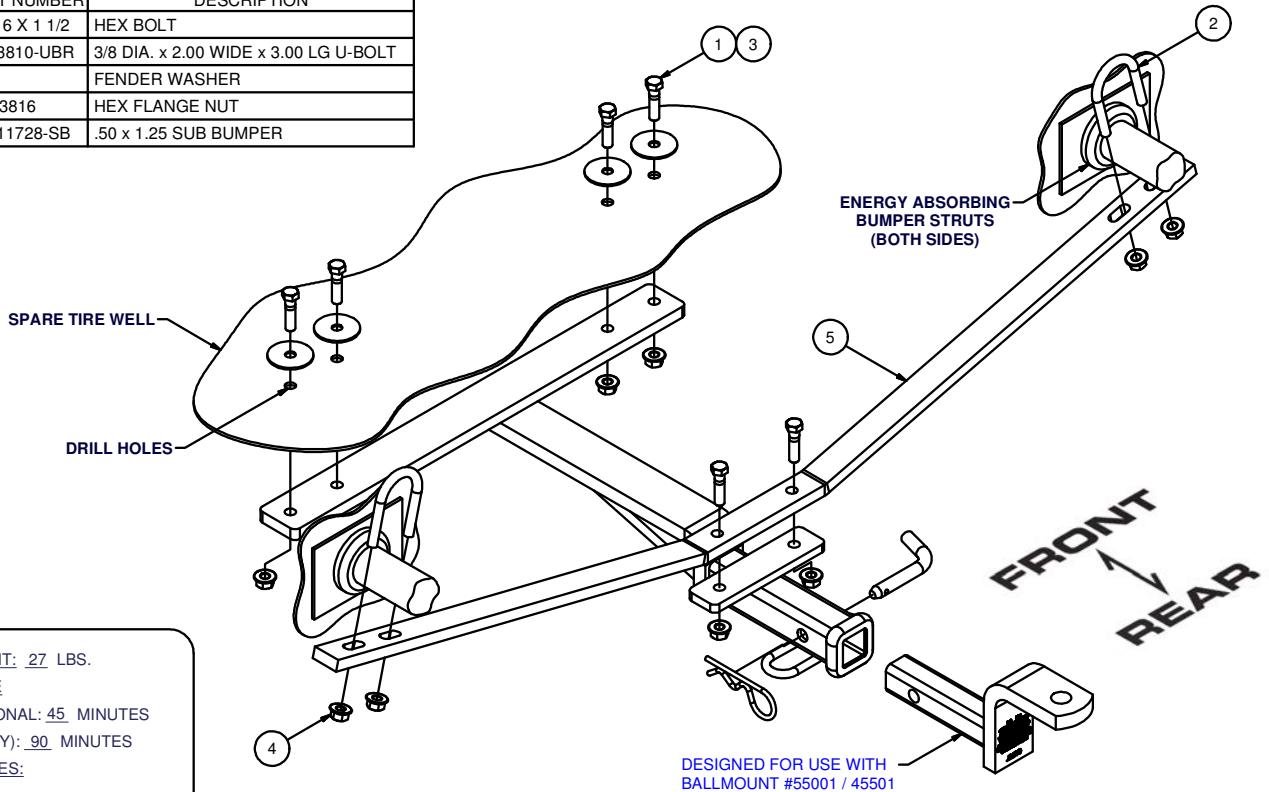

HITCH WEIGHT: 27 LBS.

INSTALL TIME

PROFESSIONAL: 45 MINUTES

NOVICE (DIY): 90 MINUTES

INSTALL NOTES:

- CLEAR TRUNK / REMOVE SPARE
- DRILLING REQUIRED
- SILICONE FASTENERS

INSTALLATION STEPS

1. This hitch includes a separate sub-bumper (CM-11728-SB) that supports the hitch under the vehicle's energy absorbing bumper struts. The hitch is also fastened at the vehicle's spare tire well.
2. Remove trunk contents and spare tire from vehicle to allow for drilling into spare tire well. Install the sub-bumper under the bumper struts as shown. DO NOT tighten completely at this time.
3. Fasten the hitch receiver assembly to the sub-bumper as shown. Adjust the completed hitch assembly fore-aft on the vehicle for the best clearance and fit on the tire well.
4. With the hitch assembly in final position, tighten U-bolt lock nuts. NOTE: DO NOT use impact wrench on U-bolts. Drill the tire well for (4) 3/8" diameter bolts using the hitch as a template.
5. Install fasteners making sure to use fender washers inside the vehicle opposite the hitch.
6. Torque all 3/8" fasteners to 45 lb-ft.
7. Apply silicone sealant around fasteners installed in trunk to seal out water and exhaust fumes.
8. Reinstall trunk contents and spare tire removed in step 2.

PERIODICALLY CHECK THIS RECEIVER HITCH TO ENSURE THAT ALL FASTENERS ARE TIGHT AND THAT ALL STRUCTURAL COMPONENTS ARE SOUND.



The **FIRST** Name in Towing Products™

Trailer Hitches