

11510 INFINITI EX35, EX37 JOURNEY & QX50 (AWD INCLUDED)

GROSS LOAD CAPACITY WHEN USED AS A WEIGHT CARRYING HITCH: 1,500 LBS. TRAILER WEIGHT & 150 LBS. TONGUE WEIGHT.

DO NOT EXCEED VEHICLE MANUFACTURER'S RECOMMENDED TOWING CAPACITY.

WARNING: ALL NON-TRAILER LOADS APPLIED TO THIS PRODUCT MUST BE SUPPORTED BY AUXILIARY STABILIZING STRAPS.

** FAILURE TO PROPERLY SUPPORT NON-TRAILER LOADS WILL VOID PRODUCT WARRANTY**

Parts List			
ITEM	QTY	PART NUMBER	DESCRIPTION
1	6	3/8"	CONICAL TOOTHED WASHER
2	2	7/16"	CONICAL TOOTHED WASHER
3	2	M10 - 1.25 x 30	HEX BOLT
4	6	M8 - 1.25 x 30 TAP BOLT	HEX HEAD TAP BOLT

TOOLS REQUIRED

STRAIGHT SCREW DRIVER

RATCHET

3" SOCKET EXTENSION

10" SOCKET EXTENSION

12mm SOCKET

14mm SOCKET

TORQUE WRENCH

RUBBER ISOLATOR REMOVAL DIAGRAM

This technique can be used if and Exhaust Hanger Removal Pliers is not available.

Using a 5/8" open end wrench, slide the wrench up to the rubber isolator, cradling the hanger rod as shown. Next place the flat edge of a pry bar between the wrench and the hanger stop or hanger rod. Then simply rotate the pry bar toward the wrench to remove the rubber isolator.

Note: Using a spray lubricant or soapy water on the hanger rod and the rubber isolator helps removal.

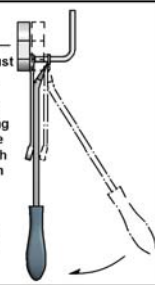

DRIVER SIDE FRAME RAIL

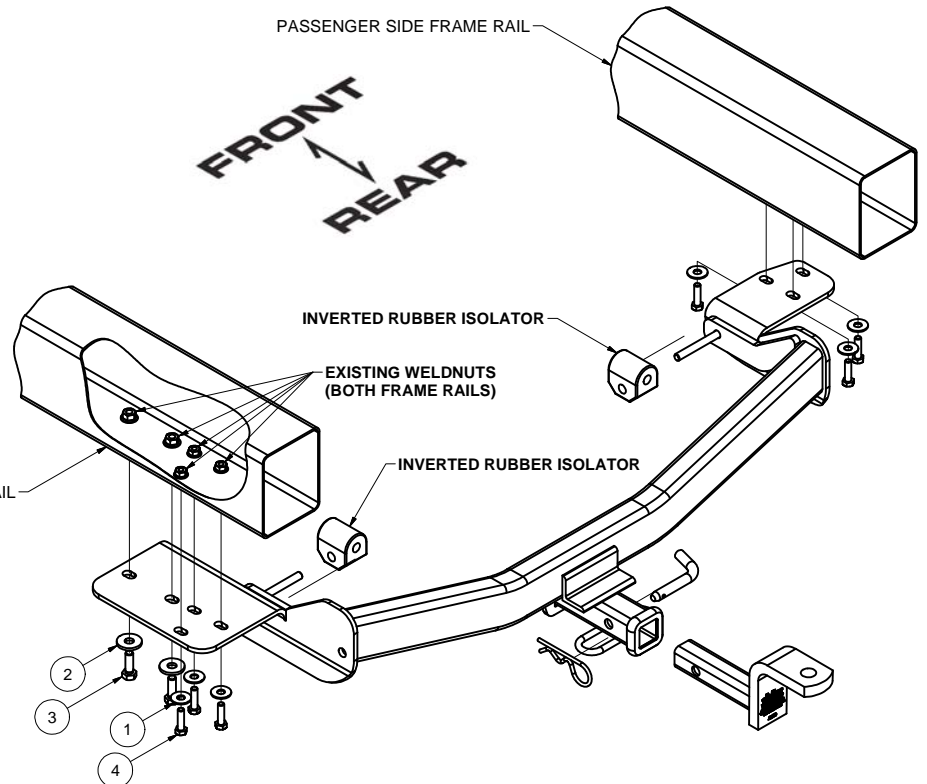

NOTE: IT IS RECOMMENDED TO HAVE TWO PEOPLE TO EASE THE INSTALL.

HITCH WEIGHT: 30 LBS.

INSTALL TIME

PROFESSIONAL: 60 MINUTES

NOVICE (DIY): 120 MINUTES

INSTALL NOTES:

- NO DRILLING REQUIRED
- LOWER EXHAUST
- REMOVE TOW LOOP
- ATTACH EXHAUST TO HITCH

INSTALLATION STEPS

1. Remove (3) exhaust hanger bolts per side on rear hangers, remove long bolt from driver side hanger on other side of muffler, and remove (1) nut from each of the exhaust hangers just forward from the rear axle. The exhaust should rest on cross brace under the exhaust.
2. Remove exhaust hanger from rubber isolator and return to customer. Remove tow loop and return to customer (both sides).
3. Raise hitch and muffler into position, such that exhaust hanger pegs on muffler are above exhaust hanger studs on hitch. Loosely install the supplied 8mm and 10mm bolts and washers. Invert both of the rubber isolators as shown above.
Note: If hitch and muffler are not raised together, muffler will not be able to be reinstalled with hitch in place.
4. Invert rubber isolators attached to muffler. Install rubber isolators over studs on hitch.
5. Torque all 8mm fasteners to 23 lb-ft and all 10mm fasteners to 45 lb-ft.

PERIODICALLY CHECK THIS RECEIVER HITCH TO ENSURE THAT ALL FASTENERS ARE TIGHT AND THAT ALL STRUCTURAL COMPONENTS ARE SOUND.



The **FIRST** Name
in Towing Products™

Trailer Hitches