

11482

## 03-06 INFINITI G35 / G35X SEDAN

GROSS LOAD CAPACITY WHEN USED AS A WEIGHT CARRYING HITCH: 2,000 LBS. TRAILER WEIGHT &amp; 200 LBS. TONGUE WEIGHT.

\*\*\*DO NOT EXCEED VEHICLE MANUFACTURER'S RECOMMENDED TOWING CAPACITY.\*\*\*

WARNING: ALL NON-TRAILER LOADS APPLIED TO THIS PRODUCT MUST BE SUPPORTED BY AUXILIARY STABILIZING STRAPS.

\*\* FAILURE TO PROPERLY SUPPORT NON-TRAILER LOADS WILL VOID PRODUCT WARRANTY\*\*

Parts List			
ITEM	QTY	PART NUMBER	DESCRIPTION
1	2	1/2-13 x 1 3/4	CARRIAGE BOLT
2	2	CM-SP53	.250 x 1.50 x 3.00" SQUARE HOLE SPACER
3	2	HFN 1213	HEX FLANGE NUT
4	1	CM-438-FW	7/16" FISHWIRE TOOL
5	2	7/16 - 14 x 1 3/4	CARRIAGE BOLT
6	2	CM-SP11	.250 x 1.00 x 2.50" SQUARE HOLE SPACER
7	2	7/16-14	HEX FLANGE NUT

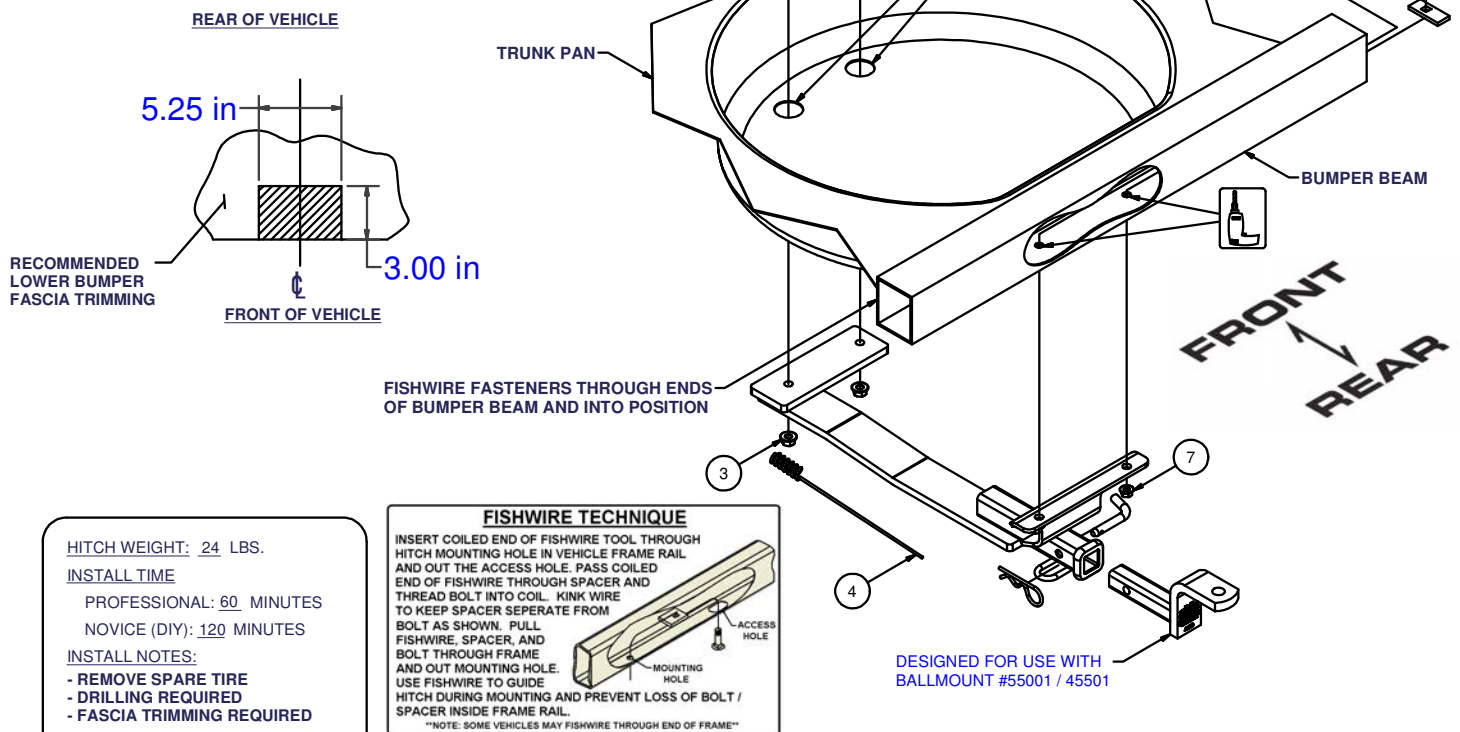

HITCH WEIGHT: 24 LBS.

**INSTALL TIME**

PROFESSIONAL: 60 MINUTES

NOVICE (DIY): 120 MINUTES

**INSTALL NOTES:**

- REMOVE SPARE TIRE
- DRILLING REQUIRED
- FASCIA TRIMMING REQUIRED

**INSTALLATION STEPS**

1. Remove spare tire from trunk for access to the trunk pan. Remove rubber plugs from trunk pan.
2. Mark and trim lower bumper fascia to recommended dimensions in the above diagram.
3. Raise hitch into position and center on vehicle. Secure hitch using 1/2" carriage bolts, spacers, and flange nuts through trunk pan holes, finger tighten.
4. Using hitch as a template, mark and center punch holes on bumper beam.
5. Lower hitch and drill bumper beam using a 1/2" drill.
6. Raise hitch back into position securing with 1/2" fasteners. **(Note: Seal trunk pan holes using silicone sealant).** Fishwire 7/16" fasteners through end of bumper beam on passenger side, through drilled holes and hitch, secure with flange nuts.
7. Torque all 1/2" fasteners to 110 ft-lb and all 7/16" fasteners to 70 ft-lb
8. Reinstall spare tire.

**PERIODICALLY CHECK THIS RECEIVER HITCH TO ENSURE THAT ALL FASTENERS ARE TIGHT AND THAT ALL STRUCTURAL COMPONENTS ARE SOUND.**



The **FIRST** Name  
in Towing Products™

Trailer Hitches