

11468**TOYOTA PRIUS**

7/13/2012

GROSS LOAD CAPACITY WHEN USED AS A WEIGHT CARRYING HITCH: 2,000 LBS. TRAILER WEIGHT & 200 LBS. TONGUE WEIGHT.

*****DO NOT EXCEED VEHICLE MANUFACTURER'S RECOMMENDED TOWING CAPACITY.*******WARNING: ALL NON-TRAILER LOADS APPLIED TO THIS PRODUCT MUST BE SUPPORTED BY AUXILIARY STABILIZING STRAPS.****** FAILURE TO PROPERLY SUPPORT NON-TRAILER LOADS WILL VOID PRODUCT WARRANTY****

Parts List			
ITEM	QTY	PART NUMBER	DESCRIPTION
1	4	3/8"	CONICAL TOOTHED WASHER
2	4	M10 - 1.25 x 25	HEX BOLT

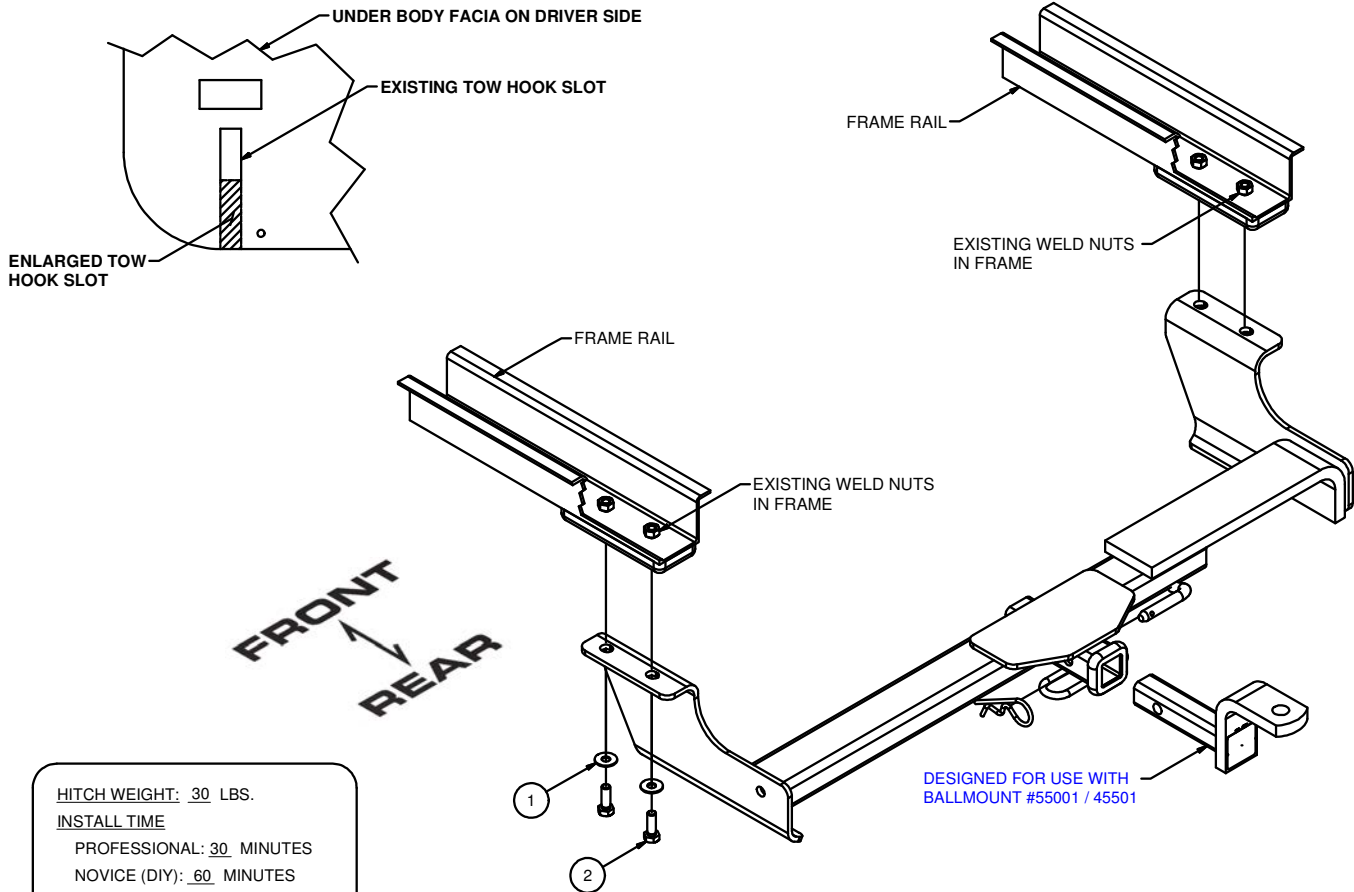

HITCH WEIGHT: 30 LBS.

INSTALL TIME

PROFESSIONAL: 30 MINUTES

NOVICE (DIY): 60 MINUTES

INSTALL NOTES:NO DRILLING REQUIRED
TRIM UNDER BODY FASCIA**INSTALLATION STEPS**

- 1) Remove tow hooks. (Return to customer)
- 2) Remove plastic under body fascia on driver side.
- 3) Lift hitch into position and secure with M10 bolts and conical washers as shown.
- 4) Torque all M10 fasteners to 48 ft-lbs.
- 5) Enlarge tow hook slot on under body fascia to fit around driver side plate as shown.
- 6) Reinstall under body fascia with existing hardware.

PERIODICALLY CHECK THIS RECEIVER HITCH TO ENSURE THAT ALL FASTENERS ARE TIGHT AND THAT ALL STRUCTURAL COMPONENTS ARE SOUND.

The **FIRST** Name
in Towing Products™

Trailer Hitches