

11447

CHEVROLET HHR, CHEVROLET COBALT SS, LS & LT, SATURN ION
ION REDLINE, PONTIAC PURSUIT, PONTIAC G5

GROSS LOAD CAPACITY WHEN USED AS A WEIGHT CARRYING HITCH: 2,000 LBS. TRAILER WEIGHT & 200 LBS. TONGUE WEIGHT.

DO NOT EXCEED VEHICLE MANUFACTURER'S RECOMMENDED TOWING CAPACITY.

WARNING: ALL NON-TRAILER LOADS APPLIED TO THIS PRODUCT MUST BE SUPPORTED BY AUXILIARY STABILIZING STRAPS.

** FAILURE TO PROPERLY SUPPORT NON-TRAILER LOADS WILL VOID PRODUCT WARRANTY**

Parts List			
ITEM	QTY	PART NUMBER	DESCRIPTION
1	4	1/2-13 x 1 1/2	CARRIAGE BOLT
2	4	CM-SP6	.250 x 1.00 x 3.00" SQUARE HOLE SPACER
3	4	HFN 1213	HEX FLANGE NUT
4	1	1/2"	FISHWIRE TOOL

RUBBER ISOLATOR REMOVAL DIAGRAM

This technique can be used if and Exhaust Hanger Removal Pliers is not available.

Using a 5/8" open end wrench, slide the wrench up to the rubber isolator, cradling the hanger rod as shown. Next place the flat edge of a pry bar between the wrench and the hanger stop or hanger rod. Then simply rotate the pry bar toward the wrench to remove the rubber isolator.

Note: Using a spray lubricant or soapy water on the hanger rod and the rubber isolator helps removal.

REVERSE PULL FISHWIRE TECHNIQUE

ATTACH FISHWIRE TO CARRIAGE BOLT AND SLIDE SPACER ONTO FISHWIRE. PUSH THE BOLT THRU THE HOLE FOLLOWED BY THE SPACER (AS SHOWN). PULL BOLT BACK INTO POSITION, PROTRUDING FROM THE FRAME.

HITCH WEIGHT: 48 LBS.
INSTALL TIME
PROFESSIONAL: 60 MINUTES
NOVICE (DIY): 120 MINUTES
INSTALL NOTES:
- DRILLING REQUIRED
- LOWER EXHAUST

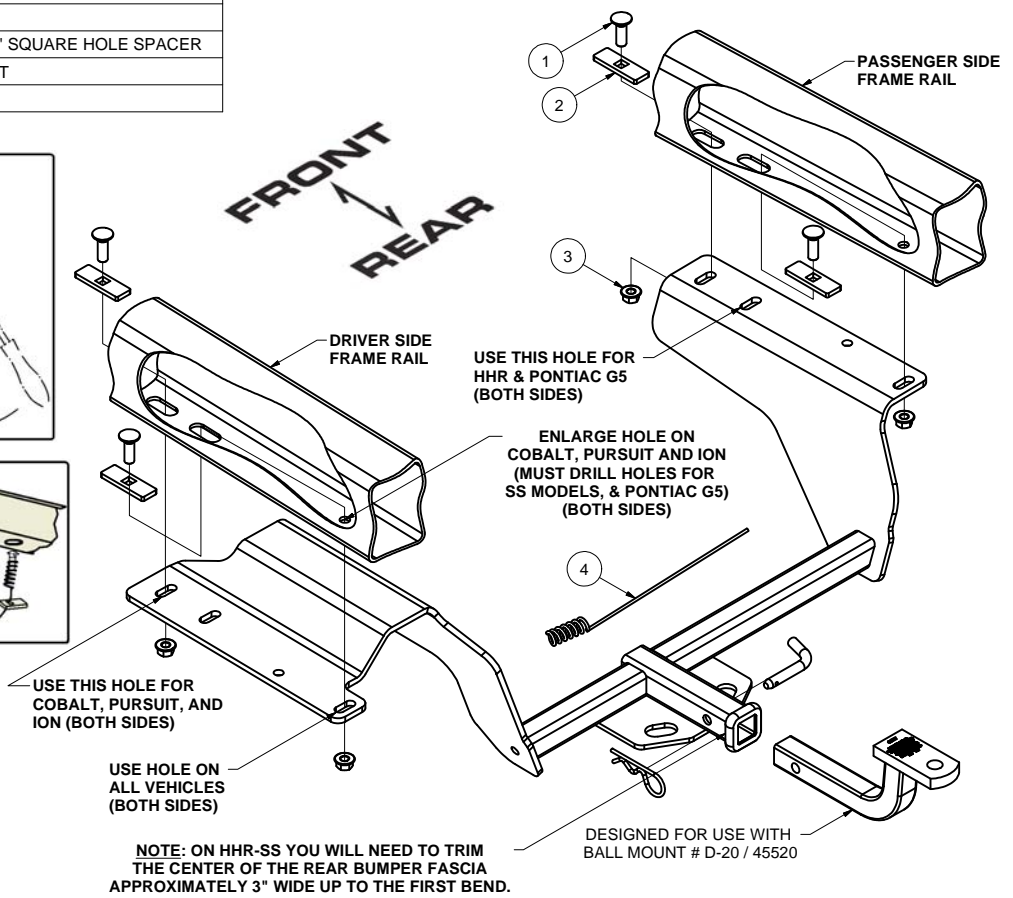

INSTALLATION STEPS

1. Drop muffler and tailpipe by removing all rubber isolators, behind rear axle, off of hangers. There will be (2) or (3) depending on vehicle. On Ion Redline rearward isolator hanger needs to be bent down slightly for fastener clearance.
2. Install rearward fasteners. On cobalt, pursuit, and ion vehicles it will be necessary to drill both rear holes. Use rearmost slot that does not go all the way through frame as guide to drill clearance hole for 1/2" bolts. On HHR it is necessary to enlarge rearmost slot on passenger side only. Fishwire 1/2" carriage bolts and blocks through access slots in bottom of frame both sides.
3. Install forward fasteners both sides. Insert carriage bolts and blocks into access slot and drop back down through slot making sure block spans both sides of slot.
4. While holding muffler down slide hitch up and over muffler into place making sure that you do not push fasteners back up into frame. Install hex flange nuts on all (4) bolts and do not tighten. **Note:** On HHR-SS you will need to trim the center of the rear bumper fascia approximately 3" wide up to the first bend.
5. Before tightening bolts slide hitch over towards the passenger's side and up against trunk pan. While holding hitch against trunk pan tighten bolts.
6. Torque all 1/2" fasteners to 110 lb-ft.
7. Reinstall muffler isolator hangers.

PERIODICALLY CHECK THIS RECEIVER HITCH TO ENSURE THAT ALL FASTENERS ARE TIGHT AND THAT ALL STRUCTURAL COMPONENTS ARE SOUND.