

11444

05-06 NISSAN XTRAIL

GROSS LOAD CAPACITY WHEN USED AS A WEIGHT CARRYING HITCH: 2,000 LBS. TRAILER WEIGHT & 200 LBS. TONGUE WEIGHT.

DO NOT EXCEED VEHICLE MANUFACTURER'S RECOMMENDED TOWING CAPACITY.

WARNING: ALL NON-TRAILER LOADS APPLIED TO THIS PRODUCT MUST BE SUPPORTED BY 18050 STABILIZING STRAPS.

** FAILURE TO PROPERLY SUPPORT NON-TRAILER LOADS WILL VOID PRODUCT WARRANTY**

Parts List			
ITEM	QTY	PART NUMBER	DESCRIPTION
1	10	3/8 - 16 x 1 1/4	HEX BOLT
2	10	3/8"	WASHER
3	10	3/8"	LOCK WASHER

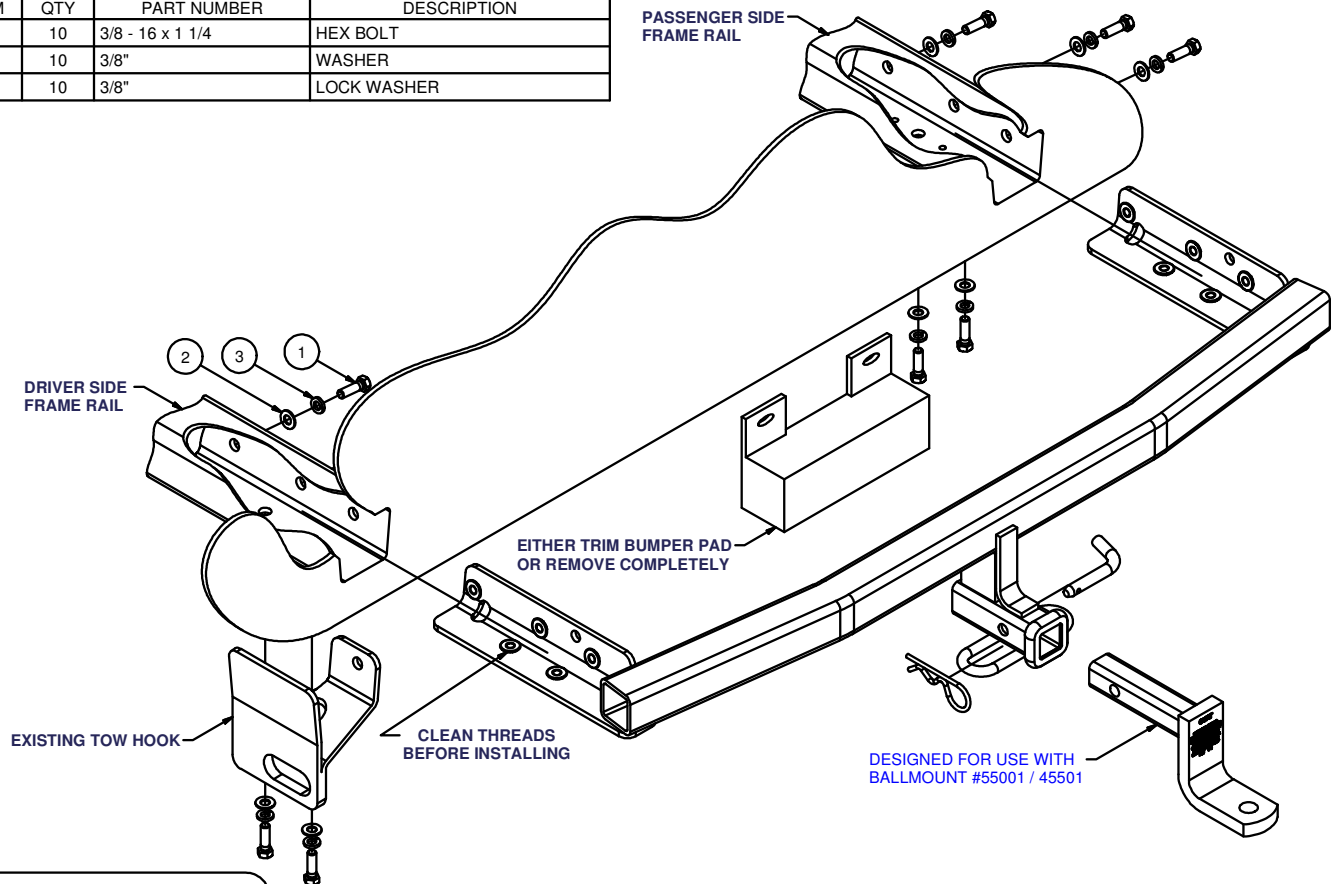

HITCH WEIGHT: 28 LBS.

INSTALL TIME

PROFESSIONAL: 60 MINUTES

NOVICE (DIY): 120 MINUTES

INSTALL NOTES:

- LOWER / RE-INSTALL BUMPER AND UNDERBODY FASCIA
- NO DRILLING REQUIRED

INSTALLATION STEPS

- 1) The following fascia fasteners must be removed for hitch installation.
 - * 5 fascia bolts
 - * 8 hex bolts
 - * both rear bumper panels on frame ends

Must remove bumper fascia from clips holding to vehicle.
- 2) Remove or trim bumper pad for hitch clearance.
- 3) Insert hitch into ends of frame rails as shown, and align hitch weldnuts with existing holes in vehicle frame rail.
- 4) Loosely install fasteners into hitch through existing frame holes as shown.
- 5) Using supplied template, align template with bumper fascia, mark and trim for hitch installation.
- 6) Torque all 3/8" fasteners to 45 ft-lbs.
- 7) Re-install bumper fascia and underbody fascia.

PERIODICALLY CHECK THIS RECEIVER HITCH TO ENSURE THAT ALL FASTENERS ARE TIGHT AND THAT ALL STRUCTURAL COMPONENTS ARE SOUND.



The **FIRST** Name
in Towing Products™

Trailer Hitches

FASCIA TRIM TEMPLATE

LINE UP WITH BOTTOM EDGE OF FASCIA

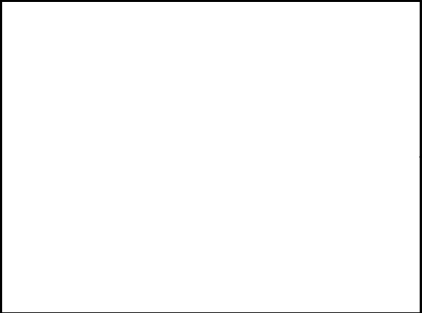

LINE UP WITH CENTER RIBS ON FASCIA

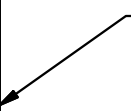

5.38 in

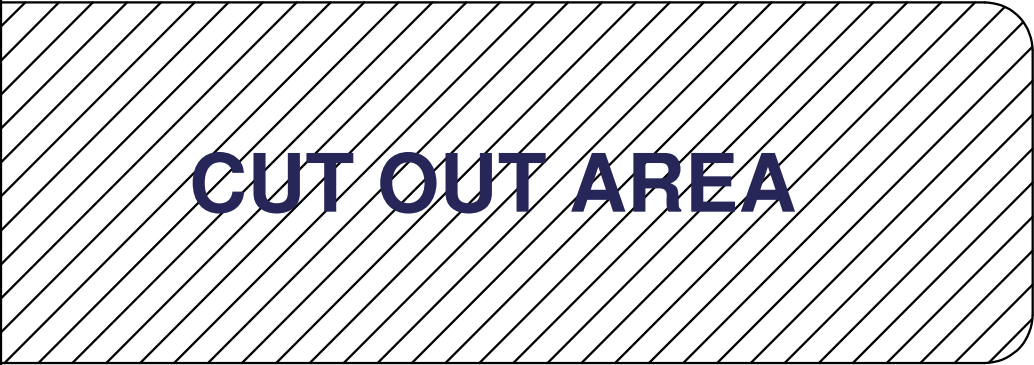

CUT OUT AREA

1.88 in

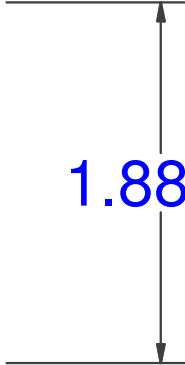

LINE UP WITH BOTTOM EDGE OF FASCIA

