

11438

VOLVO S40 / V50 WAGON

GROSS LOAD CAPACITY WHEN USED AS A WEIGHT CARRYING HITCH: 2,000 LBS. TRAILER WEIGHT & 200 LBS. TONGUE WEIGHT.

DO NOT EXCEED VEHICLE MANUFACTURER'S RECOMMENDED TOWING CAPACITY.

WARNING: ALL NON-TRAILER LOADS APPLIED TO THIS PRODUCT MUST BE SUPPORTED BY AUXILIARY STABILIZING STRAPS.

** FAILURE TO PROPERLY SUPPORT NON-TRAILER LOADS WILL VOID PRODUCT WARRANTY**

Parts List			
ITEM	QTY	PART NUMBER	DESCRIPTION
1	4	M8-1.25 x 40	HEX BOLT
2	2	1/2-13 x 1 3/4	HEX BOLT
3	2	CM-SP50	.250 x 1.00 x 1.50" ROUND HOLE SPACER
4	2	HFN 1213	HEX FLANGE NUT
5	4	5/16"	LOCK WASHER
6	4	5/16"	WASHER

**RUBBER ISOLATOR
REMOVAL DIAGRAM**

This technique can be used if and Exhaust Hanger Removal Pliers is not available.

Using a 5/8" open end wrench, slide the wrench up to the rubber isolator, cradling the hanger rod as shown. Next place the flat edge of a pry bar between the wrench and the hanger stop or hanger rod. Then simply rotate the pry bar toward the wrench to remove the rubber isolator.

Note: Using a spray lubricant or soapy water on the hanger rod and the rubber isolator helps removal.

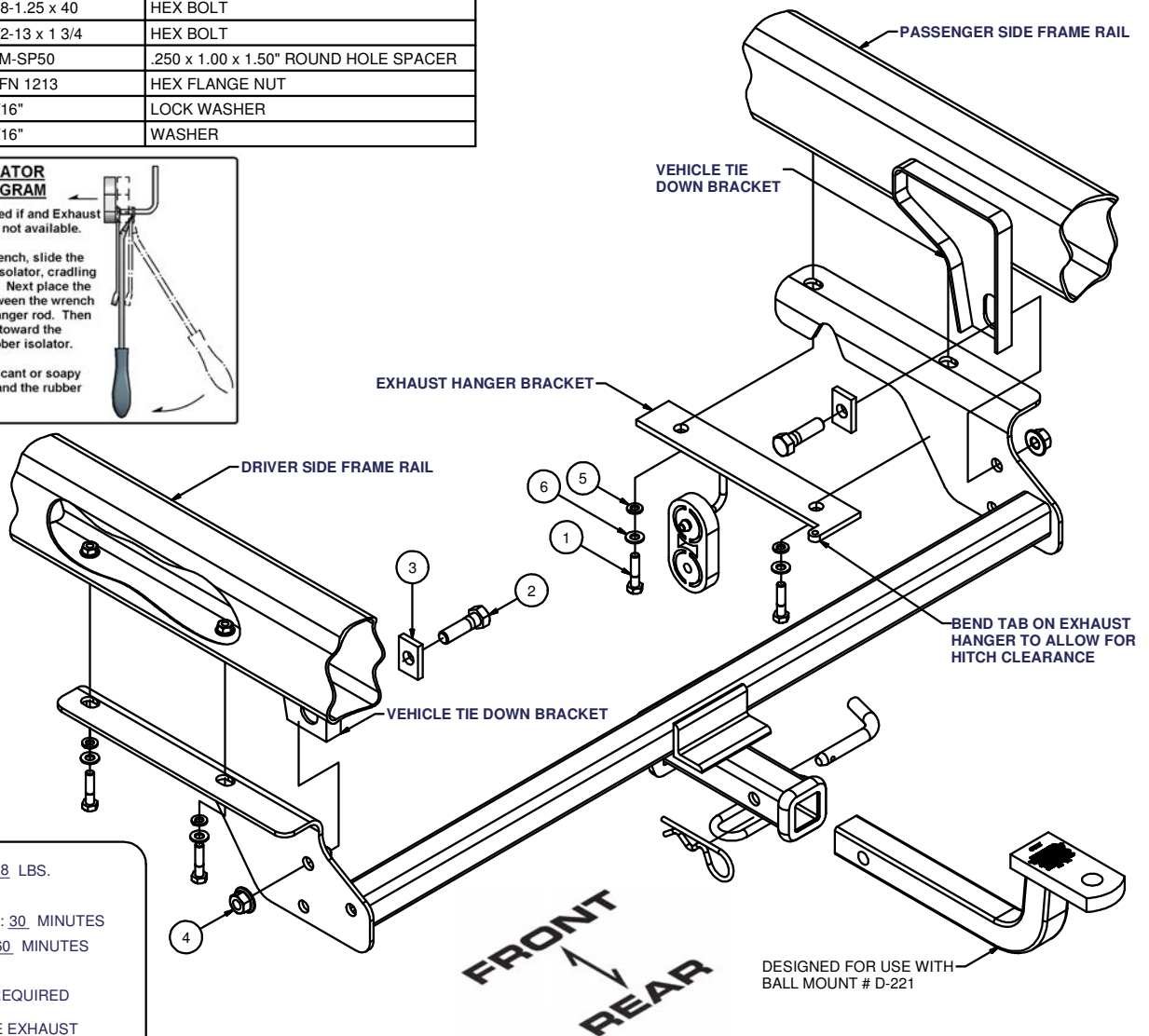
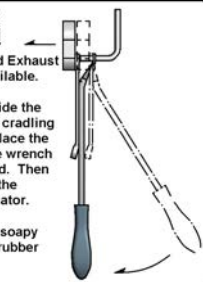

HITCH WEIGHT: 28 LBS.

INSTALL TIME

PROFESSIONAL: 30 MINUTES

NOVICE (DIY): 60 MINUTES

INSTALL NOTES:

- NO DRILLING REQUIRED

- LOWER / RAISE EXHAUST

INSTALLATION STEPS

- 1) Lower exhaust by removing two M8 bolts, each side. Discard bolts.
(Note: Bend tabs on exhaust bracket to allow clearance for hitch.)
- 2) Raise hitch into position. Loosely install M8 x 40mm bolts and 5/16" conical washers, sandwiching hitch side bracket between frame rail and exhaust hanger bracket.
- 3) Install 1/2" fasteners thru hitch side brackets and vehicle tie-down bracket as shown.
- 4) Torque all M8 fasteners to 23 lb-ft, and all 1/2" fasteners to 110 lb-ft.

PERIODICALLY CHECK THIS RECEIVER HITCH TO ENSURE THAT ALL FASTENERS ARE TIGHT AND THAT ALL STRUCTURAL COMPONENTS ARE SOUND.



The **FIRST** Name
in Towing Products™

Trailer Hitches