

11383

MAZDA 3 5-DOOR

INCLUDING SPEED 3 5-DOOR

GROSS LOAD CAPACITY WHEN USED AS A WEIGHT CARRYING HITCH: 2,000 LBS. TRAILER WEIGHT & 200 LBS. TONGUE WEIGHT.

DO NOT EXCEED VEHICLE MANUFACTURER'S RECOMMENDED TOWING CAPACITY.

WARNING: ALL NON-TRAILER LOADS APPLIED TO THIS PRODUCT MUST BE SUPPORTED BY AUXILIARY STABILIZING STRAPS.

** FAILURE TO PROPERLY SUPPORT NON-TRAILER LOADS WILL VOID PRODUCT WARRANTY**

Parts List				
ITEM	QTY	PART NUMBER	DESCRIPTION	
1	6	7/16-14	HEX FLANGE NUT	
2	6	CM-SP2	.250 x .88 x 2.25" SQUARE HOLE SPACER	
3	6	7/16-14 x 1 1/2	CARRIAGE BOLT	
4	2	7_16 FISHWIRE	7/16" FISHWIRE	

FISHWIRE TECHNIQUE

INSERT COILED END OF FISHWIRE TOOL THROUGH HITCH MOUNTING HOLE IN VEHICLE FRAME RAIL AND OUT THE ACCESS HOLE. PASS COILED END OF FISHWIRE THROUGH SPACER AND THREAD BOLT INTO COIL. KINK WIRE TO KEEP SPACER SEPERATE FROM BOLT AS SHOWN. PULL FISHWIRE, SPACER, AND BOLT THROUGH FRAME AND OUT MOUNTING HOLE. USE FISHWIRE TO GUIDE HITCH DURING MOUNTING AND PREVENT LOSS OF BOLT / SPACER INSIDE FRAME RAIL.

NOTE: SOME VEHICLES MAY FISHWIRE THROUGH END OF FRAME

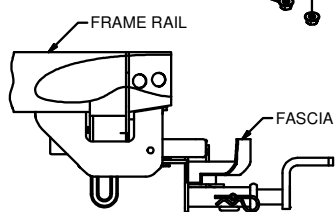
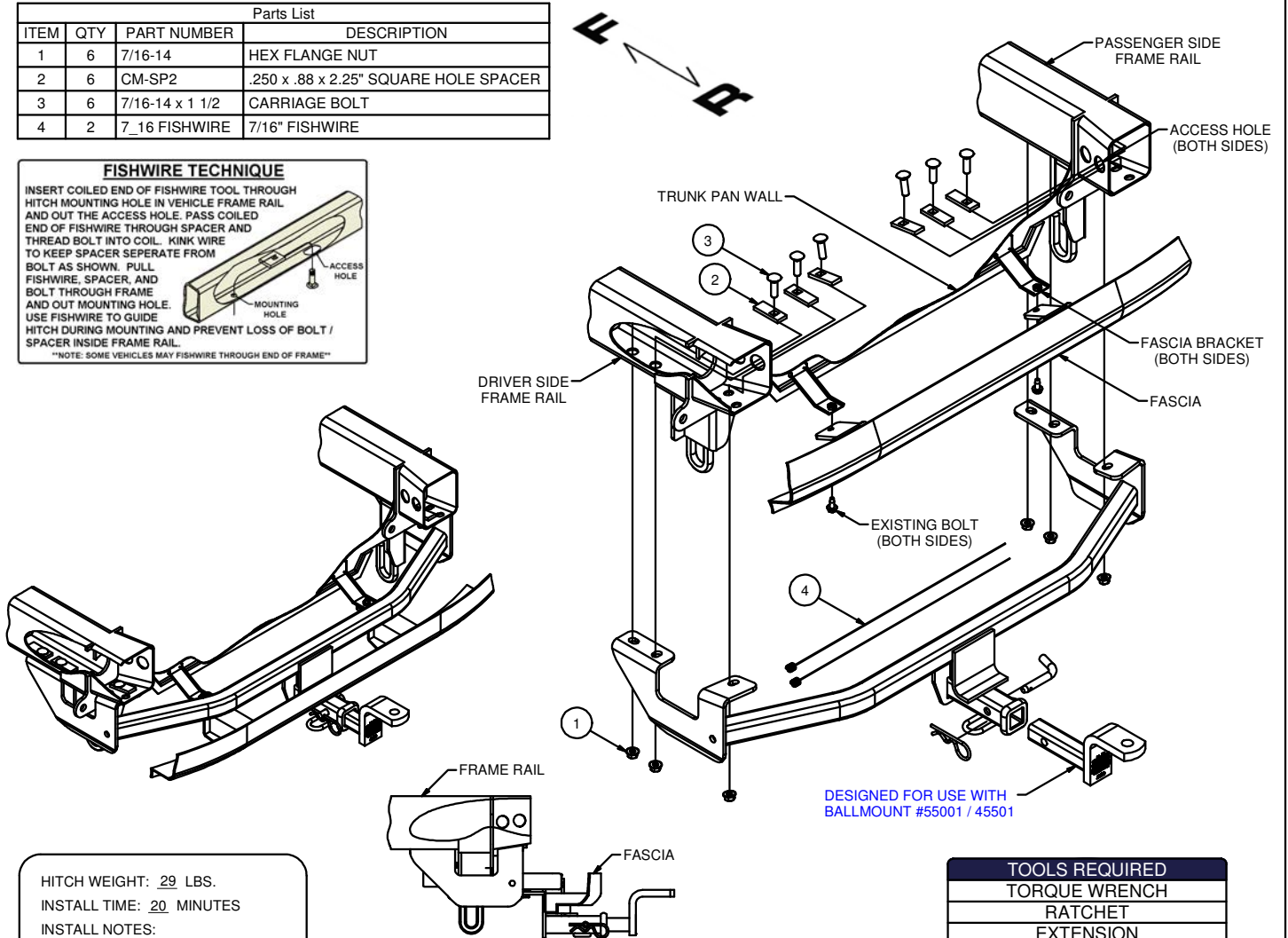

HITCH SHOWN IN PROPER POSITION

TOOLS REQUIRED
TORQUE WRENCH
RATCHET
EXTENSION
11/16" SOCKET
10mm SOCKET

HITCH WEIGHT: 29 LBS.
 INSTALL TIME: 20 MINUTES
 INSTALL NOTES:
 - NO DRILLING REQUIRED
 - FISHWIRE HARDWARE

INSTALLATION STEPS

1. Fishwire CM-SP2 spacers and 7/16-14 carriage bolts through the access hole and out the holes in the bottom of the frame rails as shown. (See Fishwire Technique.)
2. Remove existing bolts securing the fascia tabs to the fascia brackets. Bolts will be reinstalled in step (5).
3. Pull down on fascia and slide hitch between the fascia tabs and the fascia brackets.
4. Align 7/16-14 carriage bolts fishwired in step (1) with holes in hitch and secure with 7/16" flange nuts.
5. Reinstall bolts removed in step (2).
6. Torque all 7/16" hardware to 70 ft-lbs

PERIODICALLY CHECK THIS RECEIVER HITCH TO ENSURE THAT ALL FASTENERS ARE TIGHT AND THAT ALL STRUCTURAL COMPONENTS ARE SOUND.



The **FIRST** Name in Towing Products™

Trailer Hitches