



Safety glasses should be worn at all times while installing this product.

YEARS: 2014

MAKE: CADILLAC

MODEL: CTS

STYLE: SEDAN

**WARNING: NEVER EXCEED YOUR VEHICLE MANUFACTURER'S RECOMMENDED TOWING CAPACITY**

**WEIGHT CARRYING:**  
 TRAILER WEIGHT: 2,000 LBS.  
 TONGUE WEIGHT: 200 LBS.

**INSTALLATION TIME: 45/90 MIN.**

THE INSTALL TIME LISTED IS FOR PROFESSIONAL/NOVICE INSTALLERS. IF YOU ARE HESITANT TO UNDERTAKE THIS TASK ON YOUR OWN, CONTACT AN AUTHORIZED CURT INSTALLER FOR ADDITIONAL ASSISTANCE.

**INSTALLATION TIPS:**

- BEFORE YOU BEGIN INSTALLATION, READ ALL INSTRUCTIONS THOROUGHLY.
- TO EASE INSTALLATION, 2 PEOPLE MAY BE REQUIRED.
- USING PROPER TOOLS WILL GREATLY IMPROVE THE QUALITY OF THE INSTALL AND REDUCE THE TIME REQUIRED.



**INSTALLATION REQUIRES:**

SAFETY GLASSES	T-15 TORXBIT SOCKET	RATCHET
7mm 10mm 15mm 3/4" SOCKET	PRY BAR	9" SOCKET EXTENSION
TAPE MEASURE	MARKER	AVIATION SHEARS
POWER DRILL	DRILL BIT 17/32"	TORQUE WRENCH

**LEVEL OF DIFFICULTY: MODERATE**

EASY	MODERATE	CHALLENGING
	LOWER EXHAUST TO EASE INSTALLATION	
	DRILLING REQUIRED	
	FISHWIRING REQUIRED	
	HEAT SHIELD TRIMMING	
	TEMPORARY FASCIA REMOVAL	

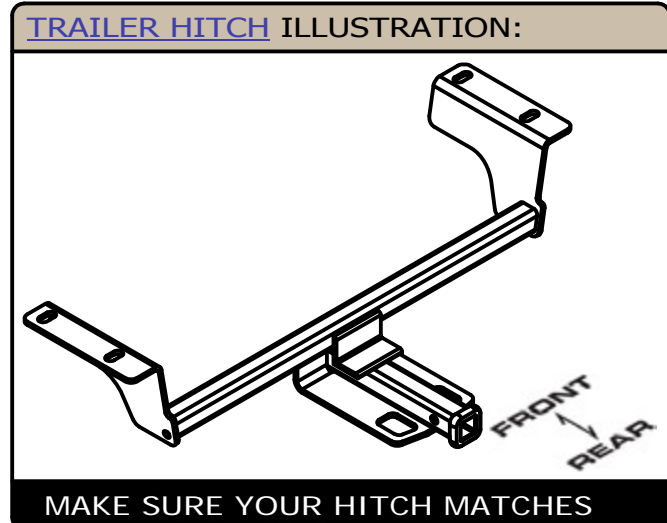

**PERIODICALLY CHECK THIS RECEIVER HITCH TO ENSURE ALL FASTENERS ARE TIGHT AND ALL STRUCTURAL COMPONENTS ARE SOUND**  
 CURT Manufacturing LLC. warrants this product to be free of defects in material and/or workmanship at the time of retail purchase by the original purchaser. If the product is found to be defective, Curt Manufacturing LLC. may repair or replace the product at their option, when the product is returned, prepaid, with proof of purchase. Alteration to, misuse of, or improper installation of this product voids the warranty. Curt Manufacturing LLC.'s liability is limited to repair or replacement of products found to be defective, and specifically excludes liability for incidental or consequential loss or damage.

# INSTALLATION WALKTHROUGH:

Parts List			
ITEM	QTY	PART NUMBER	DESCRIPTION
1	4	1/2-13 x 1 1/2	CARRIAGE BOLT
2	4	HFN 1213	HEX FLANGE NUT
3	4	CM-SP6	.250 x 1.00 x 3.00" SQUARE HOLE SPACER
4	4	1_2 x 30 FISHWIRE	1/2" x 30" FISHWIRE

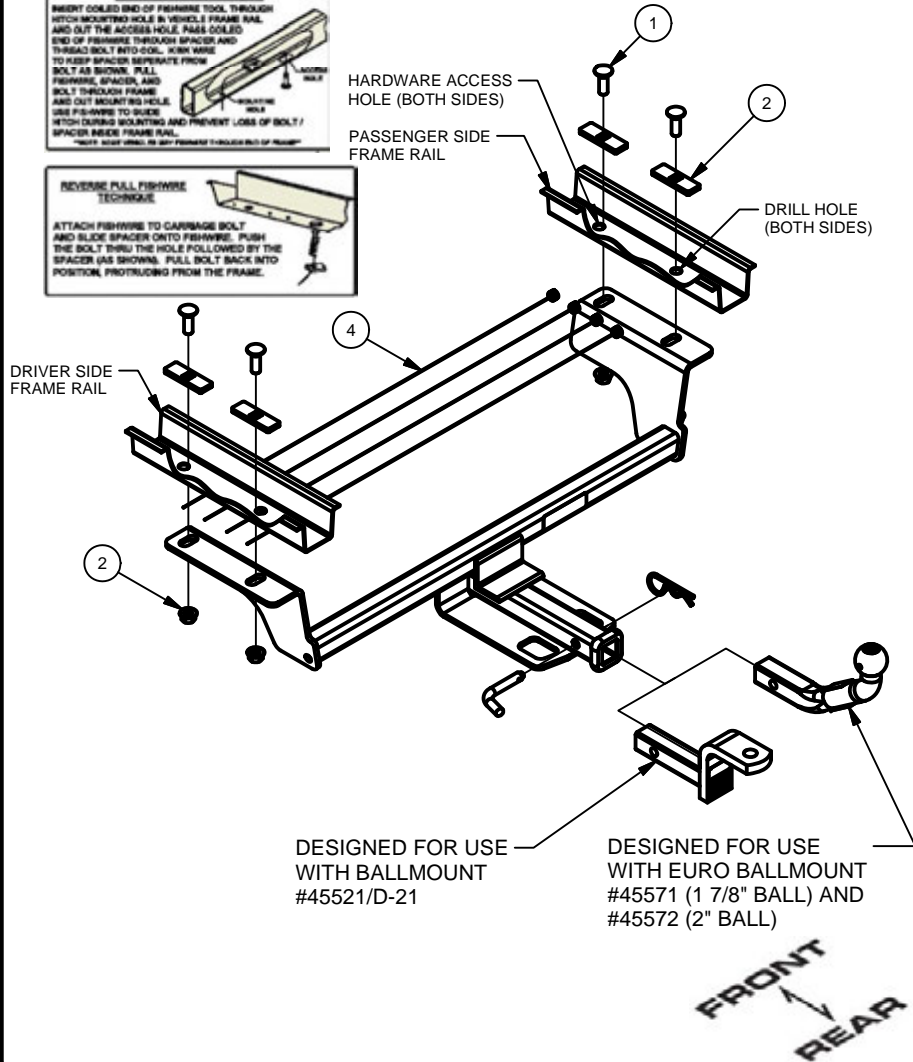

1. Remove (24) T-15 Torx screws that secure plastic fascia to the vehicle.
  - (6) at bottom center of fascia
  - (3) inside wheel well (each side)
  - (5) from underneath splash guard (each side)
  - (1) inboard of wheel well for heat shield (each side)



2. Gently pull inner fender material toward tire on each side and remove top bolt with 7mm socket. Pull off fascia completely and disconnect electrical connector from driver side.



## INSTALLATION WALKTHROUGH:

3. Lower exhaust by first removing (2) bolts on each side of the rear exhaust isolators with a 15mm socket. Remove brackets from hanger pegs on muffler. Then remove the rubber exhaust hangers, (4) places forward of mufflers (3 places on 2.0T models). **When lowered, support exhaust from underneath.**



4. Remove (2) plastic fascia supports using a 10mm socket and unclip from bumper beam. Remove heat shield by removing (10) nuts which secure it to the vehicle. Retain (8) nuts for reinstallation after heat shield trimming. (nuts can be spun off of the studs by hand, or using pliers or a pick to assist spinning)



5. Mark heat shield as shown to trim for receiver tube clearance (6" wide) and to allow access to both frame rails. Reattach trimmed heat shield using (8) of the nuts removed in Step 4.

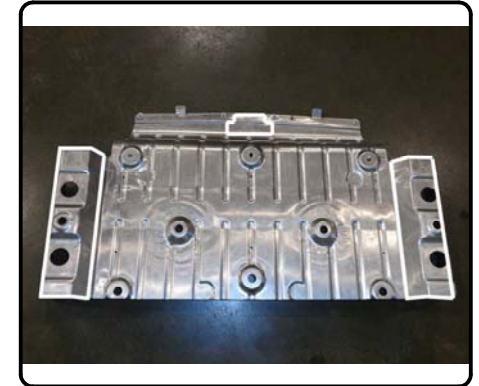
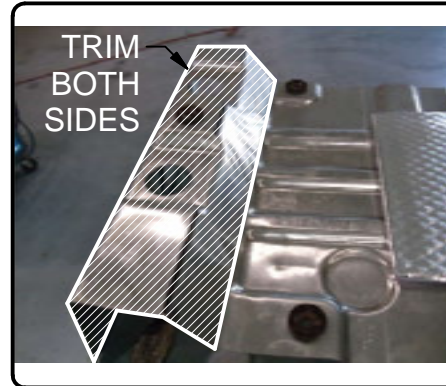

6. Raise hitch up to frame rails and align forward mounting hole with large frame access hole. Mark and drill rear frame mounting hole (17/32") on both sides using the hitch side plates as a template.

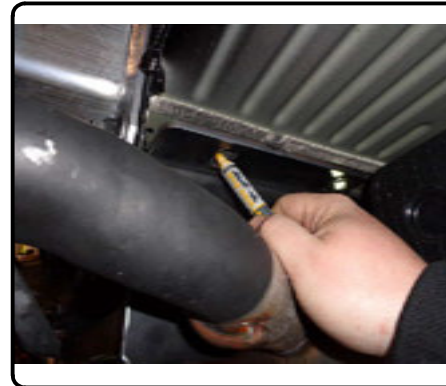

## INSTALLATION WALKTHROUGH:

7. Fishwire 1/2" carriage bolts and spacer blocks up through slots in vehicle frame and down through rear mounting holes in hitch side plates (1 place, each side). Reverse fishwire forward mounting holes through frame access hole (1 place each side)

FISHWIRE

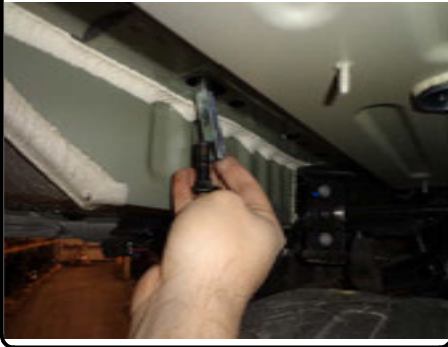

REVERSE FISHWIRE



8. Raise hitch into position, being careful not to push bolts back into frame. Secure with 1/2" hex flange nuts. Torque all 1/2" hardware to 110 lb-ft.

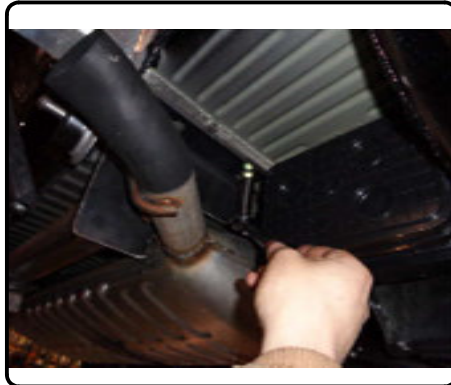

9. Raise exhaust into position by reversing all steps in Step 3-4. Reattach fascia by reversing Steps 1-2.

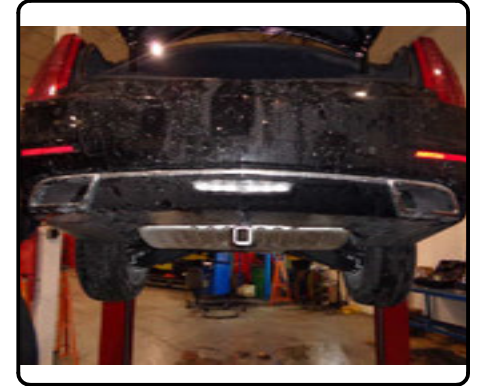

10. Installation complete.



11382

CADILLAC CTS

GROSS LOAD CAPACITY WHEN USED AS A WEIGHT CARRYING HITCH: 2,000 LBS. TRAILER WEIGHT & 200 LBS. TONGUE WEIGHT.

\*\*\*DO NOT EXCEED VEHICLE MANUFACTURER'S RECOMMENDED TOWING CAPACITY.\*\*\*

WARNING: ALL NON-TRAILER LOADS APPLIED TO THIS PRODUCT MUST BE SUPPORTED BY 18050 STABILIZING STRAPS.

\*\* FAILURE TO PROPERLY SUPPORT NON-TRAILER LOADS WILL VOID PRODUCT WARRANTY\*\*

HAVING INSTALLATION QUESTIONS? CALL TECHNICAL SUPPORT AT 1-800-798-0813

Parts List			
ITEM	QTY	PART NUMBER	DESCRIPTION
1	4	1/2-13 x 1 1/2	CARRIAGE BOLT
2	4	HFN 1213	HEX FLANGE NUT
3	4	CM-SP6	.250 x 1.00 x 3.00" SQUARE HOLE SPACER
4	4	1_2 x 30 FISHWIRE	1/2" x 30" FISHWIRE

TOOLS REQUIRED	
T-15 TORXBIT SOCKET	
RATCHET	
SOCKET SET	
PRY BAR	
POWER DRILL	
17/32" DRILL BIT	
TAPE MEASURE	
AVIATION SHEARS	
TORQUE WRENCH	

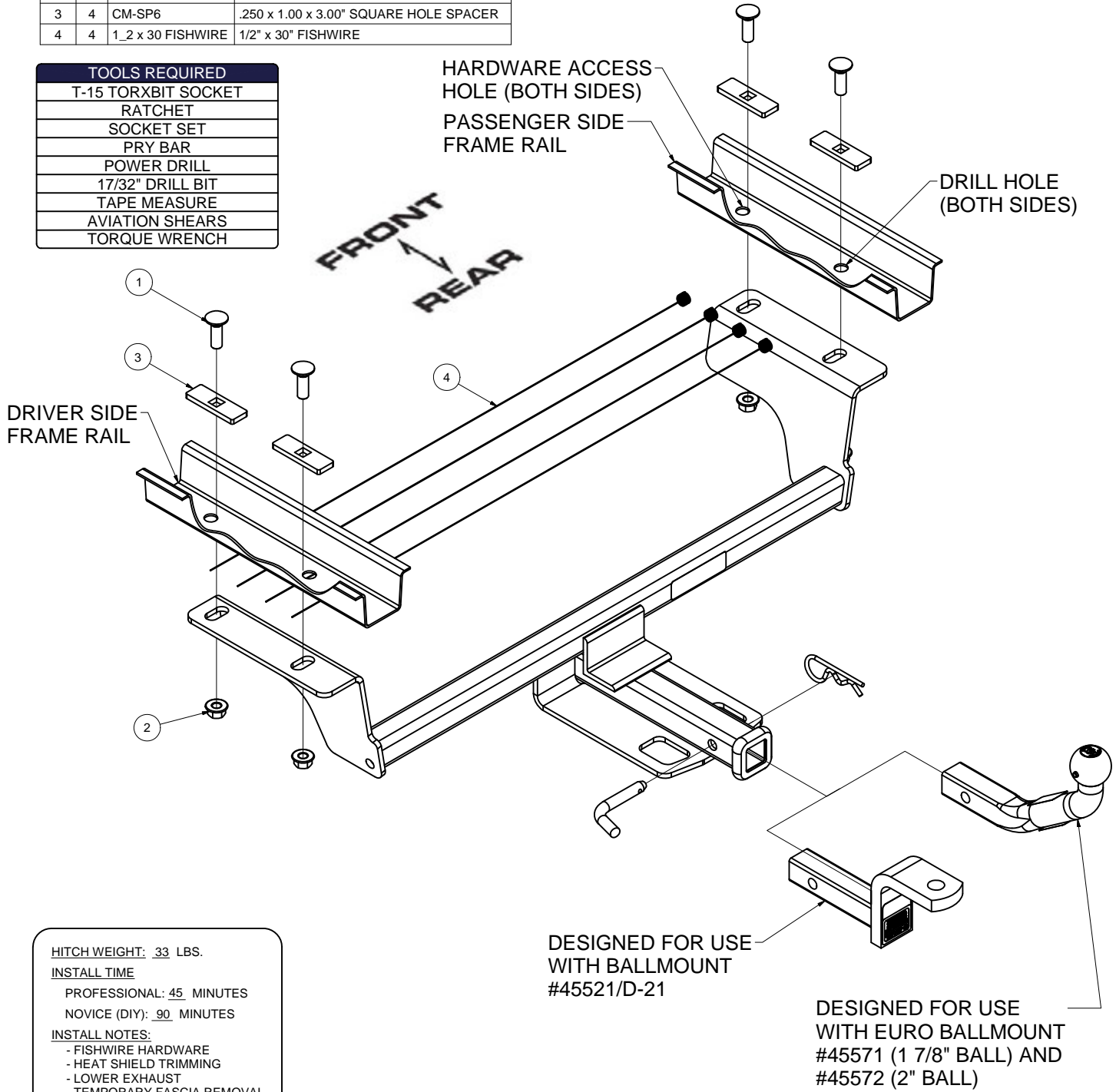

**HITCH WEIGHT:** .33 LBS.  
**INSTALL TIME**  
 PROFESSIONAL: .45 MINUTES  
 NOVICE (DIY): .90 MINUTES  
**INSTALL NOTES:**  
 - FISHWIRE HARDWARE  
 - HEAT SHIELD TRIMMING  
 - LOWER EXHAUST  
 - TEMPORARY FASCIA REMOVAL

PERIODICALLY CHECK THIS RECEIVER HITCH TO ENSURE THAT ALL FASTENERS ARE TIGHT AND THAT ALL STRUCTURAL COMPONENTS ARE SOUND.

Curt Manufacturing LLC., warrants this product to be free of defects in material and/or workmanship at the time of retail purchase by the original purchaser. If the product is found to be defective, Curt Manufacturing LLC., may repair or replace the product, at their option, when the product is returned, prepaid, with proof of purchase. Alteration to, misuse of, or improper installation of this product voids the warranty. Curt Manufacturing LLC.'s liability is limited to repair or replacement of products found to be defective, and specifically excludes liability for incidental or consequential loss or damage.



### HEAT SHIELD TRIMMING

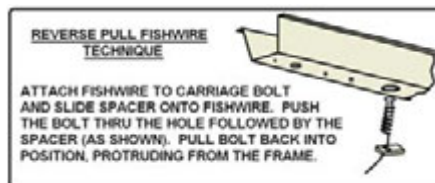
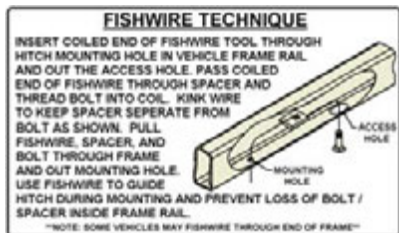

## INSTALLATION STEPS

- Remove (24) T-15 Torx screws that secure plastic fascia to the vehicle:
  - (6) at bottom center of fascia
  - (3) inside wheel well (each side)
  - (5) from underneath splash guard (each side)
  - (1) inboard of wheel well for heat shield (each side)
- Gently pull inner fender material toward tire on each side and remove top bolt with a 7mm socket. Pull off fascia completely and disconnect electrical connector from driver side.
- Lower exhaust by first removing (2) bolts on each side of the rear exhaust isolators with a 15mm socket. Remove brackets from hanger pegs on muffler. Then remove the rubber exhaust hangers, (4) places forward of muffler. (3 places on 2.0T models). **When lowered, support exhaust from underneath.**
- Remove (2) plastic fascia supports using a 10mm socket and unclip from bumper beam.
 

Remove heat shield by removing (10) nuts which secure it to the vehicle. Retain (8) nuts for reinstallation after heat shield trimming. (nuts can be spun off of the studs by hand, or using pliers or a pick to assist spinning)
- Mark heat shield as shown to trim for receiver tube clearance (6" wide) and to allow access to both frame rails. Reattach trimmed heat shield using (8) of the nuts removed in Step 4.
- Raise hitch up to frame rails and align forward mounting hold with large frame access hole. Mark and drill rear frame mounting hole (17/32") on both sides using the hitch side plates as a template.
- Fishwire 1/2" carriage bolts and spacer blocks up through slots in vehicle frame and down through mounting holes in hitch side plates (1 places, each side). Reverse fishwire forward mounting holes through frame access hole (1 place, each side).
- Raise hitch into position, being careful not to push bolts back into frame. Secure with 1/2" hex flange nuts. Torque all 1/2" hardware to 110 lb-ft.
- Raise exhaust into position by reversing all steps in Step 3-4. Reattach fascia by reversing Steps 1-2.

PERIODICALLY CHECK THIS RECEIVER HITCH TO ENSURE THAT ALL FASTENERS ARE TIGHT AND THAT ALL STRUCTURAL COMPONENTS ARE SOUND.