



Safety glasses should be worn at all times while installing this product.

YEARS: 2013-PRESENT

MAKE: LEXUS

MODEL: ES 350 / ES 300h

STYLE: SEDAN

WARNING: NEVER EXCEED YOUR VEHICLE MANUFACTURER'S RECOMMENDED TOWING CAPACITY

WEIGHT CARRYING:
 TRAILER WEIGHT: 2,000 LBS.
 TONGUE WEIGHT: 200 LBS.

PRO INSTALL TIME: 60 MIN.
NOVICE INSTALL TIME: 120 MIN.

IF YOU ARE HESITANT TO UNDERTAKE THIS TASK ON YOUR OWN, CONTACT AN AUTHORIZED CURT INSTALLER FOR ADDITIONAL ASSISTANCE.

INSTALLATION REQUIRES:

<p>10mm 12mm 14mm SHORT 14mm LONG 17mm 11/16"</p> <p>SOCKET</p>	<p>6"</p> <p>SOCKET EXTENSION</p>	<p>RATCHET</p>
<p>TORQUE WRENCH</p>	<p>AVIATION SHEARS</p>	<p>MASKING TAPE</p>
<p>TAPE MEASURE</p>	<p>SCREW DRIVER</p>	<p>SAFETY GLASSES</p>
<p>DIE GRINDER</p>	<p>PRY BAR</p>	

INSTALLATION TIPS:

- BEFORE YOU BEGIN INSTALLATION, READ ALL INSTRUCTIONS THOROUGHLY.
- TO EASE INSTALLATION, 2 PEOPLE MAY BE REQUIRED.
- USING PROPER TOOLS WILL GREATLY IMPROVE THE QUALITY OF THE INSTALL AND REDUCE THE TIME REQUIRED.

LEVEL OF DIFFICULTY: MODERATE

EASY	MODERATE	CHALLENGING
<p>PART REMOVAL</p>	- REMOVE 2 BRACKETS - REMOVE UNDERBODY PANEL - REMOVE HEAT SHIELD(S)	
<p>TRIM</p>	ENLARGE HOLES TO REVERSE FISHWIRE (2) FASTENERS	
<p>TRIM</p>	TRIM UNDERBODY PANEL	
	DUAL EXHAUST - 7 ISOLATORS SINGLE EXHAUST - 5 ISOLATORS	
	CLEAN WELDNUTS IF NEEDED	

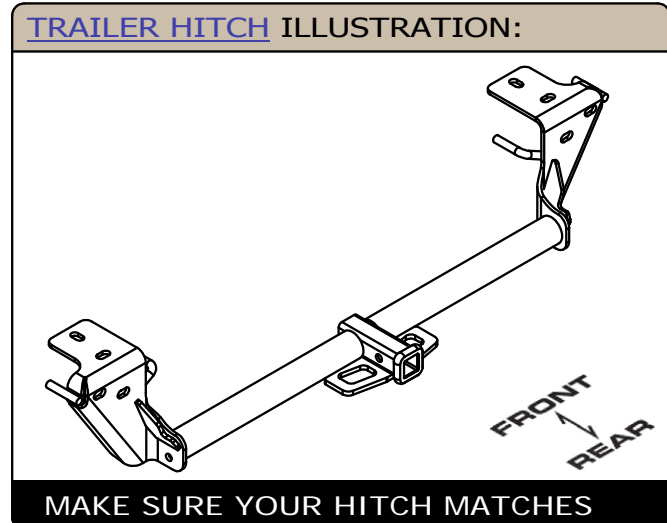

PERIODICALLY CHECK THIS RECEIVER HITCH TO ENSURE ALL FASTENERS ARE TIGHT AND ALL STRUCTURAL COMPONENTS ARE SOUND

CURT Manufacturing LLC. warrants this product to be free of defects in material and/or workmanship at the time of retail purchase by the original purchaser. If the product is found to be defective, Curt Manufacturing LLC. may repair or replace the product at their option, when the product is returned, prepaid, with proof of purchase. Alteration to, misuse of, or improper installation of this product voids the warranty. Curt Manufacturing LLC.'s liability is limited to repair or replacement of products found to be defective, and specifically excludes liability for incidental or consequential loss or damage.

INSTALLATION WALKTHROUGH:

Parts List			
ITEM	QTY	PART NUMBER	DESCRIPTION
1	2	7_16 - 14 x 1 1_4 CARRIAGE	CARRIAGE BOLT
2	2	CM-SP2	.250 x .88 x 2.25" SQUARE HOLE SPACER
3	2	7/16-14	HEX FLANGE NUT
4	2	7_16 FISHWIRE	7/16" FISHWIRE

RUBBER ISOLATOR REMOVAL DIAGRAM

This technique can be used if an Exhaust Hanger Removal Pliers is not available.

Using a 5/8" open end wrench, slide the wrench up to the rubber isolator, cradling the hanger rod as shown. Next place the flat edge of a pry bar between the wrench and the hanger stop or hanger rod. Then simply rotate the pry bar toward the wrench to remove the rubber isolator.

Note: Using a spray lubricant or soapy water on the hanger rod and the rubber isolator helps removal.



WELDNUT CLEANING

To remove debris from weldnuts in frame, spray lubricant or compressed air into hole. For heavy debris, use a small wire brush. (Be careful not to damage threads).

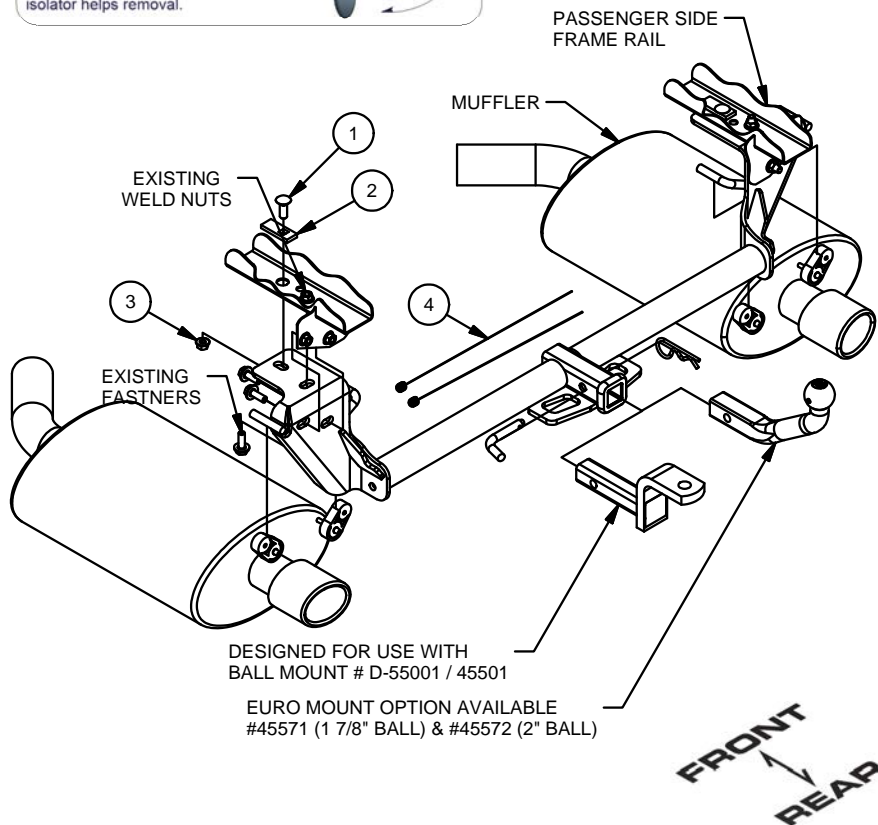

1. Start removing the underbody panel by removing the 4 screws (5 screws on single exhaust models) that fastens it to the bumper fascia using a 10mm socket.
2. Remove the 2 plastic push-button fasteners (3 fasteners on single exhaust models) with a flat blade screw driver.

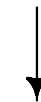

3. Unthread the 3 plastic nuts with a 10mm socket, towards the front of the vehicle and 2 plastic nuts in the center of the panel with a 12mm socket.
4. Single exhaust models only, remove 1 screw attaching the underbody cover to the driver side frame rail with a 10mm socket.



INSTALLATION WALKTHROUGH:

5. Support the exhaust and lower by removing the (2) rubber isolators by each muffler, 1 hanger on the in front of the passenger side muffler and (1-2) center isolators. Allow exhaust to be lowered 6-10".

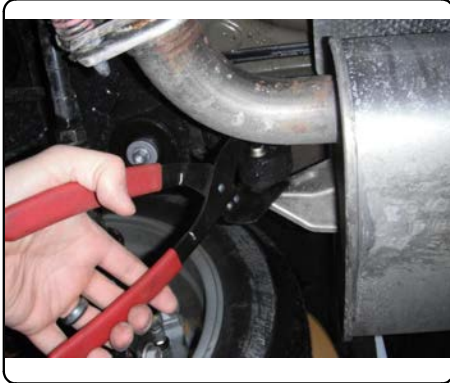

6. Remove the (2) tie down / exhaust hanger brackets from the frame using a 14mm socket. Return brackets to vehicle owner but keep hardware and rubber isolators for step 9.

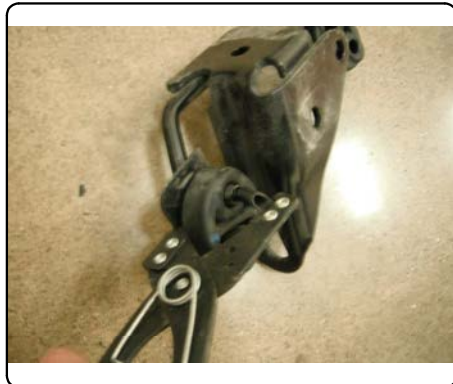

7. Remove heat shield(s) using a 10mm socket for access to frame rails.

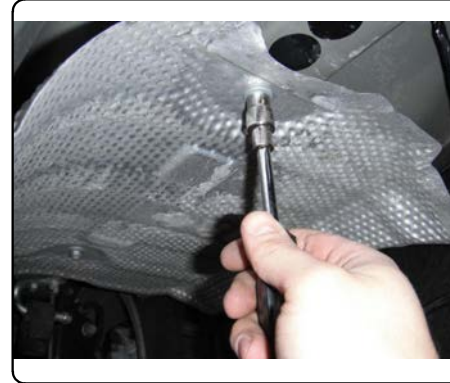

8. Locate the large hole in the frame rail on each side. Using a die grinder enlarge to allow the carriage bolt and spacer to pass through.

9. Reverse fishwire the bolt and spacer into the enlarged hole on each side using the fishwires provided.



INSTALLATION WALKTHROUGH:

10. Raise hitch into position. Using the fasteners from the brackets, attach hitch to the vertical flange and the frame rail with fasteners removed in step 6.

NOTE: To reinstall heat shield, trim to allow bolts to pass through and clamp between hitch and frame.



11. Torque all 10mm fasteners to 56 lb-ft and all 7/16" fasteners to 70 lb-ft.

12. Raise exhaust back into location and re-install rubber isolators.



13. ON SINGLE EXHAUST MODEL ONLY: Trim the underbody panel as shown in the diagrams below for the hitch to pass through.



14. Re-install the underbody cover.

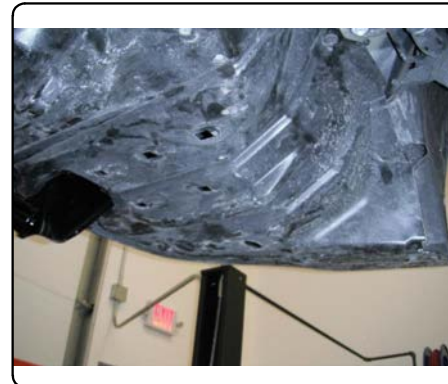

TOWING SAFETY INFORMATION

Gross Trailer Weight / GTW

The Gross Trailer Weight is the weight of the trailer & cargo. Measure this by putting the fully loaded trailer on a vehicle scale.



Tongue Weight / TW

The downward force that is exerted on the hitch ball by the coupler. The tongue weight will vary depending on where the load is positioned in relationship to the trailer axle(s). To measure the tongue weight, use either a commercial scale or a bathroom scale with the coupler at towing height. When using a bathroom scale with heavier tongue weights, use the method shown and multiply the scale reading by 3.

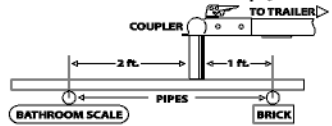

Weight Carrying / WC

The total weight of both the trailer and the cargo inside. Never exceed the weight capacity of your trailer hitch.

Weight Distribution / WD

Used to balance the weight of the cargo between the front and rear wheels throughout the trailer, allowing for better steering, braking, and level riding.



Sway Control

A device used to reduce the lateral movements of the trailer that are caused by the wind. This works in conjunction with a weight distribution hitch. Do not use this on a class 1 or 2 hitch, or with surge brakes.

How Much Can You Safely Tow?

TONGUE WEIGHT (lb)	1000	2000	3000	4000	5000	6000	7000	8000	10,000	12,000
Tongue weight should be about 10 to 15 percent of the gross trailer weight.										
CLASS 1										
CLASS 2										
CLASS 3										
CLASS 4										
CLASS 5										
TRAILER TYPE										
Camper	11'	12'	13'	14'	15'	16'				
lbs.	1100	1200	1300	1400	1500	1600				
Vacation	18'	19'	20'	21'	22'	24'	26'	28'	30'	32'
lbs.	2100	2400	2700	3000	3300	3600	3900	4200	4500	4800
Vacation	18'	19'	20'	21'	22'	24'	26'	28'	30'	32'
lbs.	2800	3200	3600	4000	4400	4800	5200	5600	6000	6400
5th Wheel										

Refer to owner's manual for towing capabilities and limitations.

Ball Mount

The ball mount is placed inside the opening of the receiver hitch which is mounted to the vehicle. Make sure a hitch pin and clip is properly securing the ball mount to the receiver hitch before you begin towing.

- A: Rise. B: Drop. C: Hole Size. D: Length.

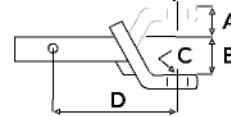

Trailer Ball

The connection from the hitch to the trailer. There are many factors that determine the correct hitch ball:

- Number one is the hitch ball's gross trailer weight rating.
- The mounting platform must be at least 3/8" thick.
- The hole diameter must not be more than 1/16" larger than the threaded shank.
- Every time you tow, check the nut and lock washer to make sure they are fastened securely.
- A: Ball Dia. B: Shank Length. C: Shank Dia. D: Shank Rise.

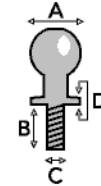

Coupler

The component that is placed over the trailer ball to connect the vehicle to the trailer. Be sure that the coupler size matches the size of the hitch ball and that the coupler handle is securely fastened. To determine what size hitch ball you need for your application you will need to know the size of coupler that is on the trailer. Be sure your coupler is properly adjusted to the ball you are using.

NOTE: For added security the use of safety devices such as Coupler Safety Pins and Locks is strongly recommended.

Safety Chains

Safety chains are a requirement and should be crossed under the tongue of the trailer so that the tongue will not drop to the road if it becomes separated from the hitch. Always leave enough slack so you can turn. Never allow the safety chains to drag on the ground and never attach the chains to the bumper.

Trailer Classification: Safety Chain Breaking Force - Minimum

Class 1: 2,000 lbs. (8.9 kN)

Class 2: 3,500 lbs. (15.6 kN)

Class 3: 5,000 lbs. (22.2 kN)

The strength rating of each length of safety chain or its equivalent and its attachments shall be equal to or exceed in minimum breaking force the GVWR (Gross Vehicle Weight Rating) of the trailer.

Electrical

Trailer lights, Electric Brakes, Break-away systems - Every time you tow, be sure to check that all components are working properly.

Wiring identification by color:

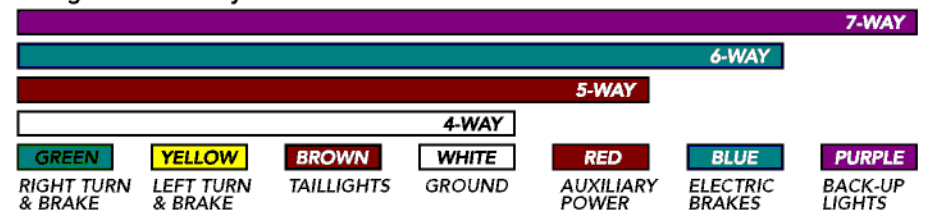

CURT DISCLAIMER: WIRING COLOR SHOWN WORK IN CONJUNCTION WITH CURT MANUFACTURING PRODUCTS.

11362

LEXUS ES 350 AND 300h

GROSS LOAD CAPACITY WHEN USED AS A WEIGHT CARRYING HITCH: 2,000 LBS. TRAILER WEIGHT & 200 LBS. TONGUE WEIGHT.

DO NOT EXCEED VEHICLE MANUFACTURER'S RECOMMENDED TOWING CAPACITY.

WARNING: ALL NON-TRAILER LOADS APPLIED TO THIS PRODUCT MUST BE SUPPORTED BY 18050 STABILIZING STRAPS.

** FAILURE TO PROPERLY SUPPORT NON-TRAILER LOADS WILL VOID PRODUCT WARRANTY**

Parts List			
ITEM	QTY	PART NUMBER	DESCRIPTION
1	2	7_16 - 14 x 1 1_4 CARRIAGE (GRADE 8)	CARRIAGE BOLT
2	2	CM-SP2	.250 x .88 x 2.25" SQUARE HOLE SPACER
3	2	7/16-14	HEX FLANGE NUT
4	2	7_16 FISHWIRE	7/16" FISHWIRE

TOOLS REQUIRED
RATCHET
6" EXTENSION
10mm SOCKET
12mm SOCKET
14mm SHORT & LONG SOCKET
17mm SOCKET
TORQUE WRENCH
RUBBER ISOLATOR REMOVER
AVIATOR SHEARS
MASKING TAPE
TAPE MEASURE
SCREW DRIVER
DIE GRINDER

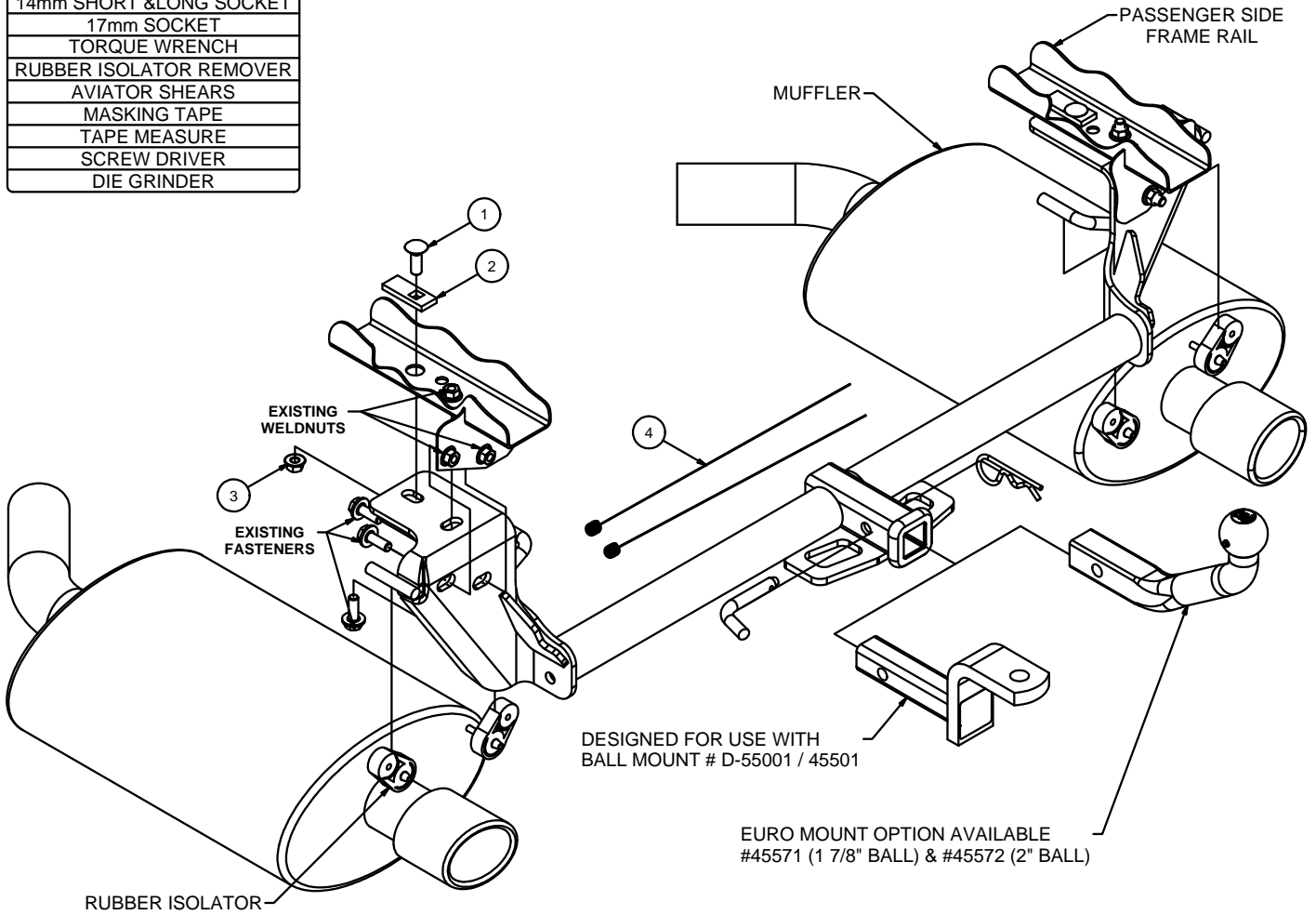
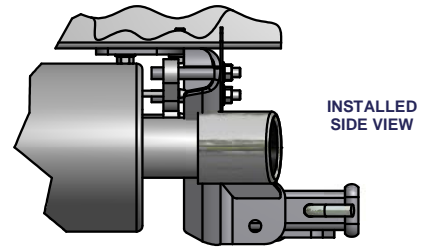

HITCH WEIGHT: 22 LBS.
INSTALL TIME
 PROFESSIONAL: 60 MINUTES
 NOVICE (DIY): 120 MINUTES
INSTALL NOTES:
 - MAY REQUIRE TRIMMING
 - NO DRILLING REQUIRED
 - LOWER EXHAUST



PERIODICALLY CHECK THIS RECEIVER HITCH TO ENSURE THAT ALL FASTENERS ARE TIGHT AND THAT ALL STRUCTURAL COMPONENTS ARE SOUND.

Curt Manufacturing LLC., warrants this product to be free of defects in material and/or workmanship at the time of retail purchase by the original purchaser. If the product is found to be defective, Curt Manufacturing LLC., may repair or replace the product, at their option, when the product is returned, prepaid, with proof of purchase. Alteration to, misuse of, or improper installation of this product voids the warranty. Curt Manufacturing LLC.'s liability is limited to repair or replacement of products found to be defective, and specifically excludes liability for incidental or consequential loss or damage.

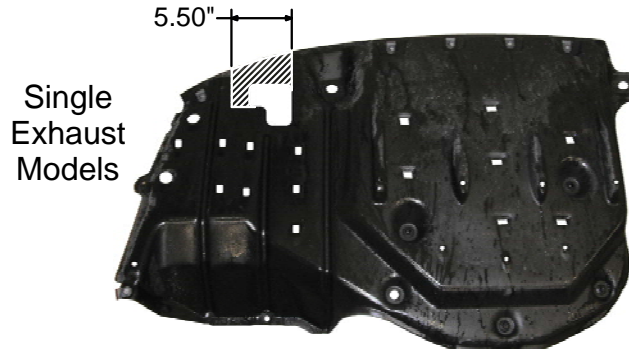
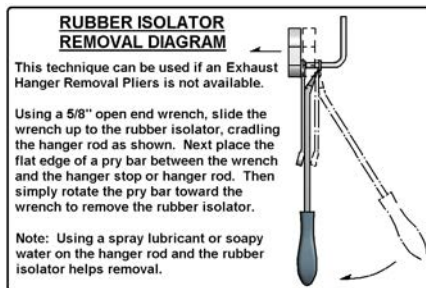
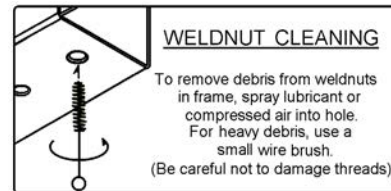
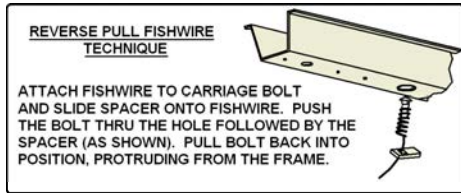

INSTALLATION STEPS

1. Remove the underbody panel by removing the 4 screws (5 on single exhaust models) in the bumper fascia using a 10mm socket. Remove the 2 push-button fasteners (3 on single exhaust models), unthreading the (3) plastic nuts (10mm socket) towards the front of the vehicle, and unthreading the (2) plastic nuts (12mm socket) in the center of the panel. On single exhaust models, remove (1) screw attaching the underbody cover to the driver side frame rail.
2. Support the exhaust and lower by removing the (2) rubber isolators by each muffler, 1 hanger on the passenger side by the muffler and (1-2) center isolators (leave isolator by engine attached). Allow exhaust to be lowered 6-10".
3. Remove the (2) tie down / exhaust hanger brackets from the frame using a 14mm socket. Return brackets to vehicle owner but keep hardware and rubber isolators for step 5.
4. Remove heat shield(s) using a 10mm socket for access to frame rails. Locate the large hole in the frame rail on each side and using a die grinder enlarge to allow bolts and spacers to pass through. Reverse fishwire the supplied bolts and spacers into the enlarged holes on each side using the fishwires provided. Trim the heat shield as required to allow bolts to pass through.
5. Raise hitch into position, clamp the heat shield(s) between the hitch and the vehicle frame. Using the fasteners from the brackets, attach hitch to the vertical flange and the frame rail with the fasteners removed in step 3.
6. Torque all 10mm fasteners to 56 lb-ft and all 7/16" fasteners to 70 lb-ft.
7. Raise exhaust back into location and re-install rubber isolators.
8. ON SINGLE EXHAUST MODEL ONLY: Trim the underbody panel, as shown in the diagrams above, for the hitch to pass through.
9. Re-install the underbody cover.

PERIODICALLY CHECK THIS RECEIVER HITCH TO ENSURE THAT ALL FASTENERS ARE TIGHT AND THAT ALL STRUCTURAL COMPONENTS ARE SOUND.