

11338

MAZDA 5

GROSS LOAD CAPACITY WHEN USED AS A WEIGHT CARRYING HITCH: 2,000 LBS. TRAILER WEIGHT & 200 LBS. TONGUE WEIGHT.

DO NOT EXCEED VEHICLE MANUFACTURER'S RECOMMENDED TOWING CAPACITY.

WARNING: ALL NON-TRAILER LOADS APPLIED TO THIS PRODUCT MUST BE SUPPORTED BY AUXILIARY STABILIZING STRAPS.

** FAILURE TO PROPERLY SUPPORT NON-TRAILER LOADS WILL VOID PRODUCT WARRANTY**

| Parts List | | | |
|------------|-----|---------------------------|--|
| ITEM | QTY | PART NUMBER | DESCRIPTION |
| 1 | 2 | CM-SP2 | .250 x .88 x 2.25" SQUARE HOLE SPACER |
| 2 | 2 | 7/16 - 14 x 1 3/4 | CARRIAGE BOLT |
| 3 | 2 | 3_8 - 16 x 4 1_2 CARRIAGE | CARRIAGE BOLT |
| 4 | 2 | CM-SP18 | .250 x 1.00 x 2.00" SQUARE HOLE SPACER |
| 5 | 1 | CM-438-FW | 7/16" FISHWIRE TOOL |
| 6 | 2 | HFN3816 | HEX FLANGE NUT |
| 7 | 2 | 7/16-14 | HEX FLANGE NUT |

FISHWIRE TECHNIQUE

INSERT COILED END OF FISHWIRE TOOL THROUGH HITCH MOUNTING HOLE IN VEHICLE FRAME RAIL AND OUT THE ACCESS HOLE. PASS COILED END OF FISHWIRE THROUGH SPACER AND THREAD BOLT INTO COIL. KINK WIRE TO KEEP SPACER SEPERATE FROM BOLT AS SHOWN. PULL FISHWIRE, SPACER, AND BOLT THROUGH FRAME AND OUT MOUNTING HOLE. USE FISHWIRE TO GUIDE HITCH DURING MOUNTING AND PREVENT LOSS OF BOLT / SPACER INSIDE FRAME RAIL.

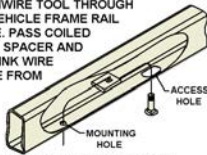

***NOTE: SOME VEHICLES MAY FISHWIRE THROUGH END OF FRAME**

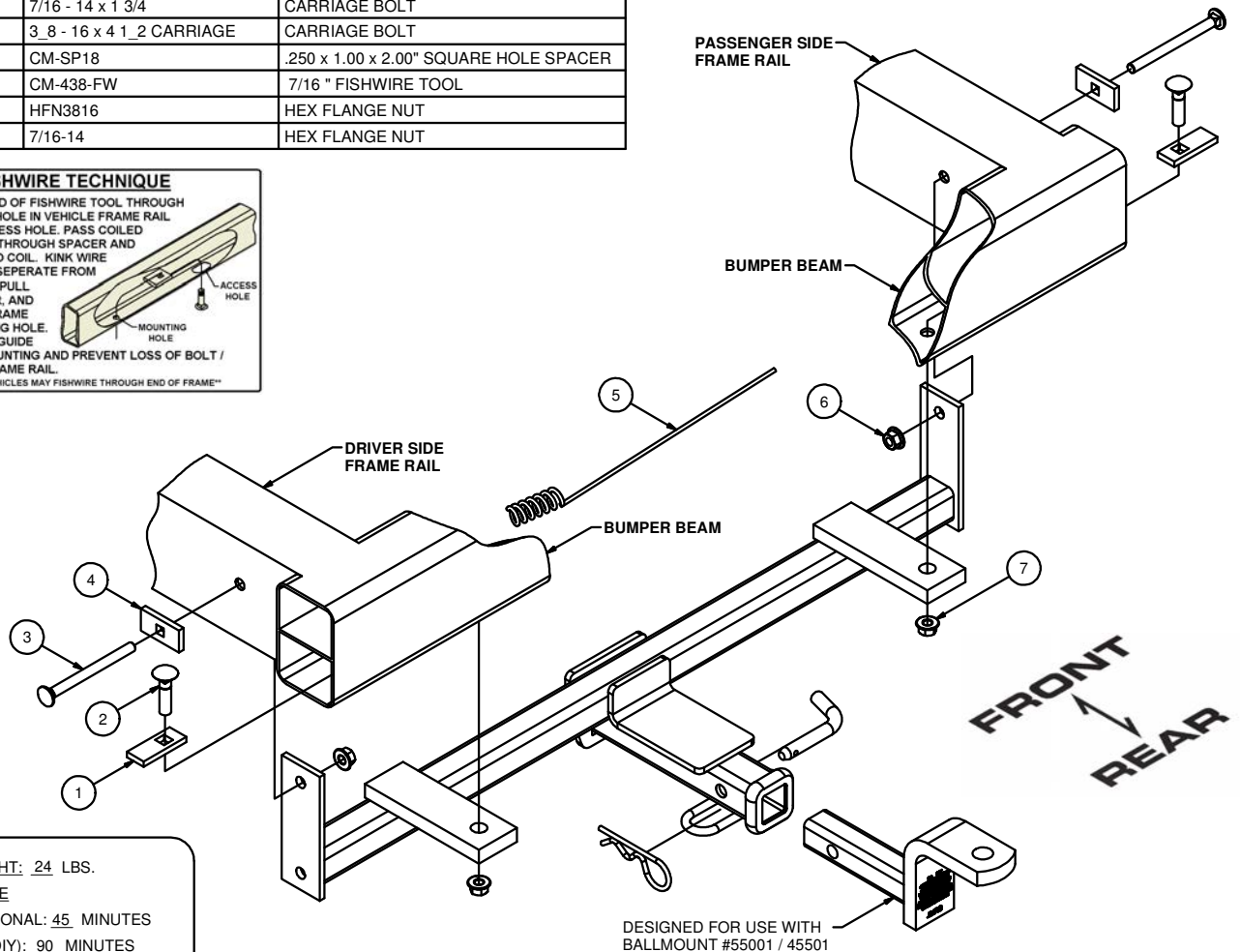

HITCH WEIGHT: 24 LBS.

INSTALL TIME

PROFESSIONAL: 45 MINUTES

NOVICE (DIY): 90 MINUTES

INSTALL NOTES:

- ENLARGE EXISTING HOLES

INSTALLATION STEPS

- 1) Locate hitch between frame rails and raise hitch into position. Install 4 1/2" carriage bolts and square hole spacers as shown.
- 2) Enlarge existing holes in bumper beam where necessary and position hitch against bumper beam. Fishwire 7/16" bolts and square hole spacers into position as shown. Install hex flange nuts.
- 3) Torque all 3/8" fasteners to 45 lb-ft, and all 7/16" fasteners to 70 lb-ft.

PERIODICALLY CHECK THIS RECEIVER HITCH TO ENSURE THAT ALL FASTENERS ARE TIGHT AND THAT ALL STRUCTURAL COMPONENTS ARE SOUND.



The **FIRST** Name
in Towing Products™

Trailer Hitches