



Safety glasses should be worn at all times while installing this product.

YEARS: 2011-PRESENT

MAKE: MINI COOPER

MODEL: COUNTRYMAN

STYLE: SEDAN

**WARNING: NEVER EXCEED YOUR VEHICLE MANUFACTURER'S RECOMMENDED TOWING CAPACITY**

**WEIGHT CARRYING:**  
 TRAILER WEIGHT: 2000 LBS.  
 TONGUE WEIGHT: 200 LBS.

**INSTALLATION TIME: 90/180 MIN.**

THE INSTALL TIME LISTED IS FOR PROFESSIONAL /NOVICE INSTALLERS. IF YOU ARE HESITANT TO UNDERTAKE THIS TASK ON YOUR OWN, CONTACT AN AUTHORIZED CURT INSTALLER FOR ADDITIONAL ASSISTANCE.

**INSTALLATION TIPS:**

- BEFORE YOU BEGIN INSTALLATION, READ ALL INSTRUCTIONS THOROUGHLY.
- TO EASE INSTALLATION, 2 PEOPLE MAY BE REQUIRED.
- USING PROPER TOOLS WILL GREATLY IMPROVE THE QUALITY OF THE INSTALL AND REDUCE THE TIME REQUIRED.

**VEHICLE PHOTO:**

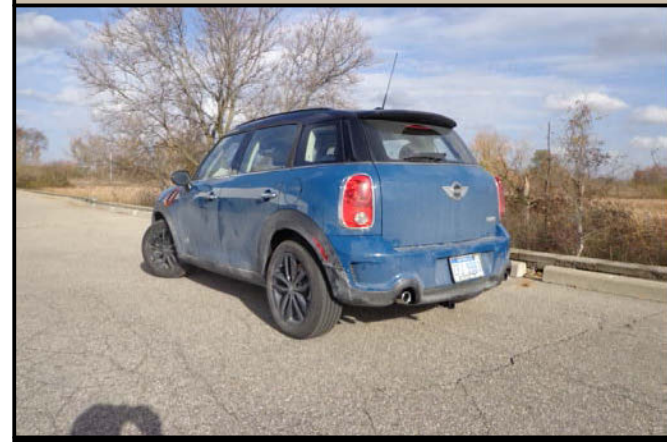

REPRESENTATIVE PHOTO

**INSTALLATION REQUIRES:**

AVIATION SHEARS	MARKER	TAPE MEASURE
TORQUE WRENCH	8mm 10mm 15mm SOCKET	RATCHET
PLASTIC RIVET GUN	SMALL PUNCH	BOXED END WRENCH 8mm
SCREW DRIVER	SIDE CUTTER	SAFETY GLASSES

**LEVEL OF DIFFICULTY: CHALLENGING**

EASY	MODERATE	CHALLENGING
		LOWER EXHAUST
		BUMPER REMOVAL
		FASCIA TRIMMING
		NO DRILLING REQUIRED

**TRAILER HITCH ILLUSTRATION:**

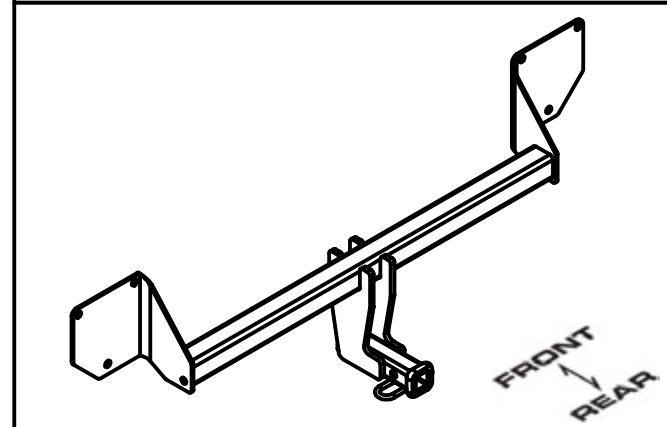

MAKE SURE YOUR HITCH MATCHES

**PERIODICALLY CHECK THIS RECEIVER HITCH TO ENSURE ALL FASTENERS ARE TIGHT AND ALL STRUCTURAL COMPONENTS ARE SOUND**

CURT Manufacturing LLC. warrants this product to be free of defects in material and/or workmanship at the time of retail purchase by the original purchaser. If the product is found to be defective, Curt Manufacturing LLC. may repair or replace the product at their option, when the product is returned, prepaid, with proof of purchase. Alteration to, misuse of, or improper installation of this product voids the warranty. Curt Manufacturing LLC.'s liability is limited to repair or replacement of products found to be defective, and specifically excludes liability for incidental or consequential loss or damage.

## INSTALLATION WALKTHROUGH:

Parts List

ITEM	QTY	PART NUMBER	DESCRIPTION
1	4	0125853	.234" PLASTIC RIVET
2	4	0125842	.246" PLASTIC RIVET

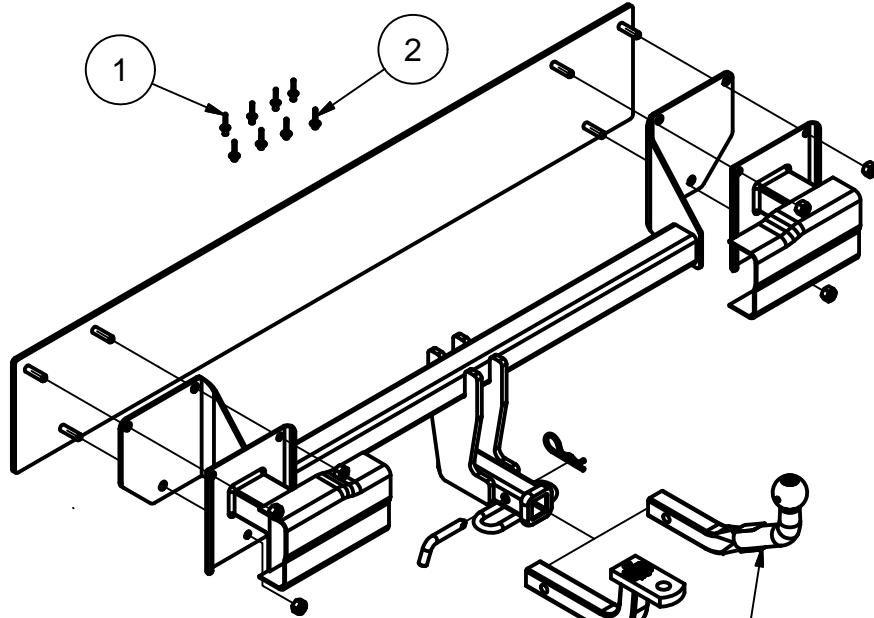

OPTIONAL BALL MOUNT  
#D-20/45520

DESIGNED FOR USE WITH EURO MOUNT  
#45562 (2" BALL) & 45561 (1 7/8" BALL)

FRONT  
↕  
REAR

1. Lower exhaust by removing 2 rubber isolators.



2. Lightly twist electrical sensor from the bumper mount clip and set aside.



## INSTALLATION WALKTHROUGH:

3. Remove (1) plastic rivet each side of the underside of the bumper cover by using a pair of side cutters and cutting off the top of the rivet. Discard removed rivets.

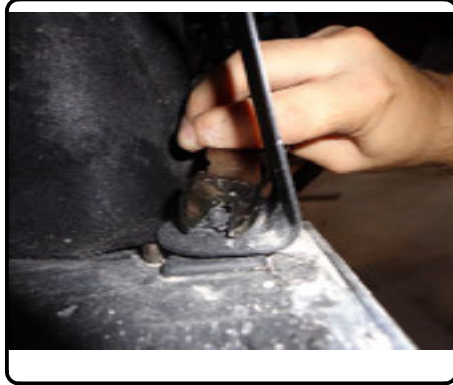

4. Remove (2) 7mm bolts from each side of the wheel well that secure the bumper fascia.

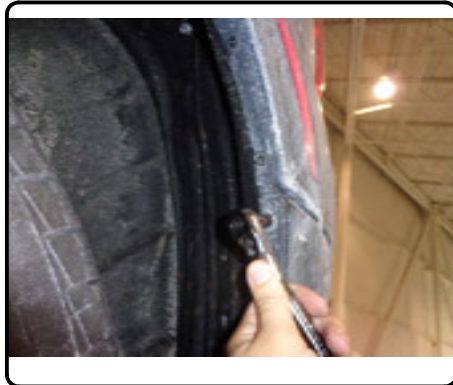
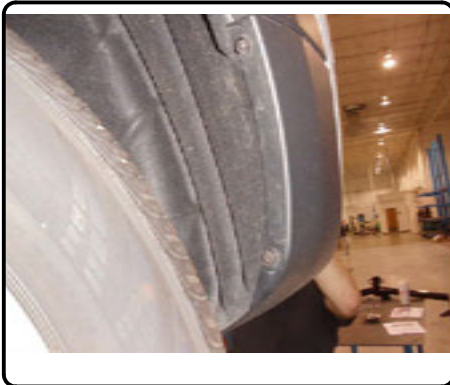

5. Remove the first (2) plastic rivets above the 7mm bolts previously removed, by pushing the center of the rivet through with a small punch and prying the head of the rivet out with a flat head screw driver.

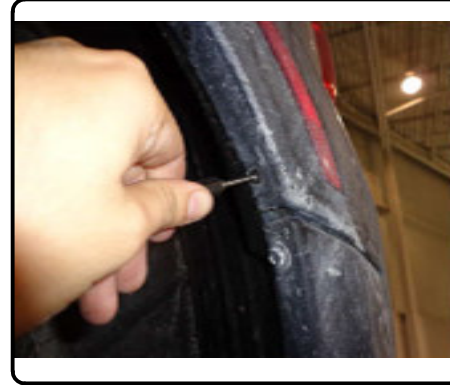

6. Lightly pull the plastic fender flare back on each side exposing an 8mm bolt and the reflector light wiring. Unbolt the 8mm bolt with a wrench and disconnect the reflector light and let hang.

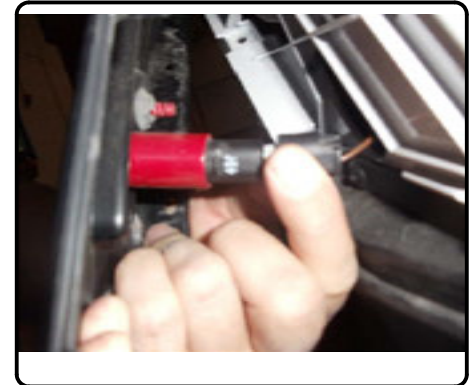
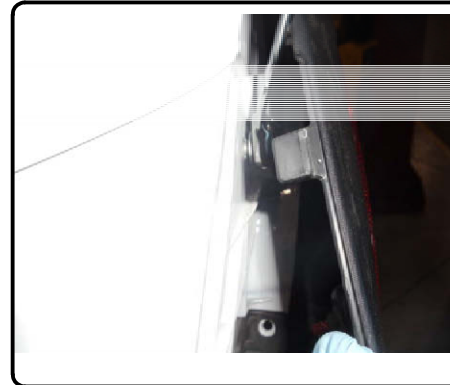

## INSTALLATION WALKTHROUGH:

7. Remove the (2) 10mm bolts from under the rear hatch securing the bumper fascia.

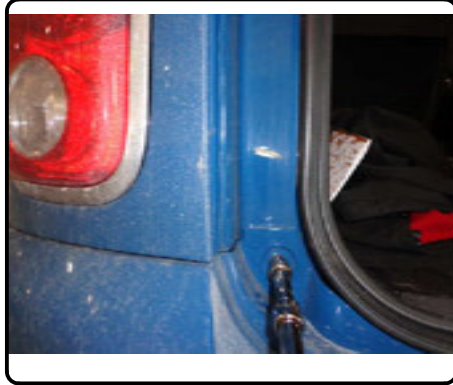

8. Remove (4) 10mm plastic nuts from the bumper braces on the underside of the vehicle as shown.



9. To remove bumper cover, gently pull each side of the bumper fascia rearward of the vehicle and set bumper cover aside. (Models with reverse sensors will need to disconnect (4) connectors)



10. Remove the (6) 15mm flange nuts attaching the bumper to the vehicle, remove bumper and set aside.



## INSTALLATION WALKTHROUGH:

11. Attach hitch to vehicle so that the hitch will be sandwiched between the frame and the bumper. Reuse the 15mm flange nuts on the (6) frame studs to secure the hitch and the bumper. Torque 15mm hardware to 35 lb-ft.

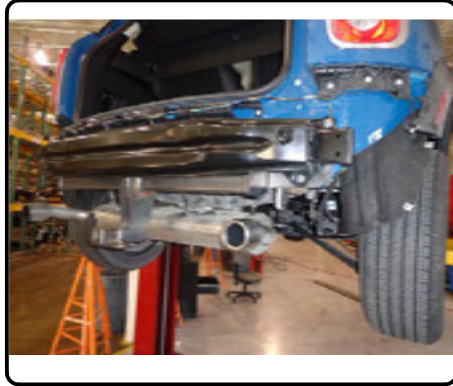

12. Trim center of bumper fascia as shown approximately 2 1/4" wide by 4 1/2" long.

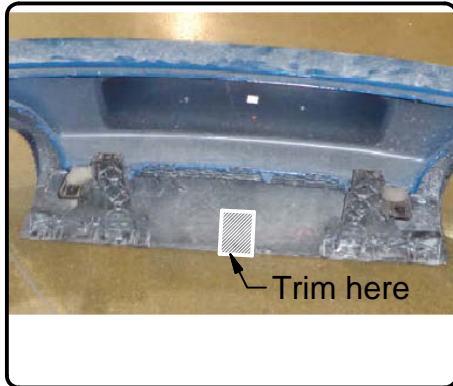

13. Reinstall the bumper cover by following the disassembly steps 1-10 in reverse. Replace (6) removed plastic rivets with those supplied in the hardware kit attach using a plasticrivet gun.



14. Installation complete.

