

11321

04-08 ACURA TL

GROSS LOAD CAPACITY WHEN USED AS A WEIGHT CARRYING HITCH: 2000 LBS. TRAILER WEIGHT & 200 LBS. TONGUE WEIGHT.

DO NOT EXCEED VEHICLE MANUFACTURER'S RECOMMENDED TOWING CAPACITY.

WARNING: ALL NON-TRAILER LOADS APPLIED TO THIS PRODUCT MUST BE SUPPORTED BY AUXILIARY STABILIZING STRAPS.

** FAILURE TO PROPERLY SUPPORT NON-TRAILER LOADS WILL VOID PRODUCT WARRANTY**

Parts List			
ITEM	QTY	PART NUMBER	DESCRIPTION
1	4	1/2-13 x 1 3/4	CARRIAGE BOLT
2	2	CM-SP4	.250 x 1.50 x 3.00" SQUARE HOLE SPACER
3	4	HFN 1213	HEX FLANGE NUT
4	1	1/2"	FISHWIRE TOOL

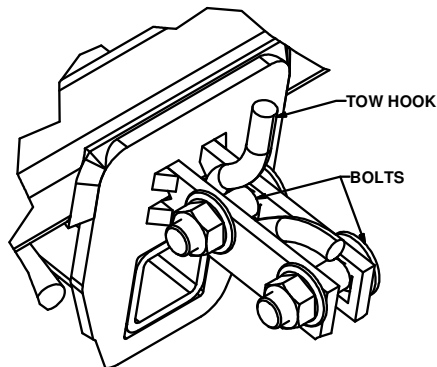
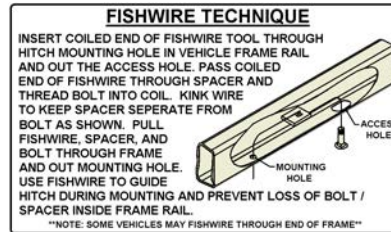

FINAL ASSEMBLED
TOW HOOK / HITCH TABS

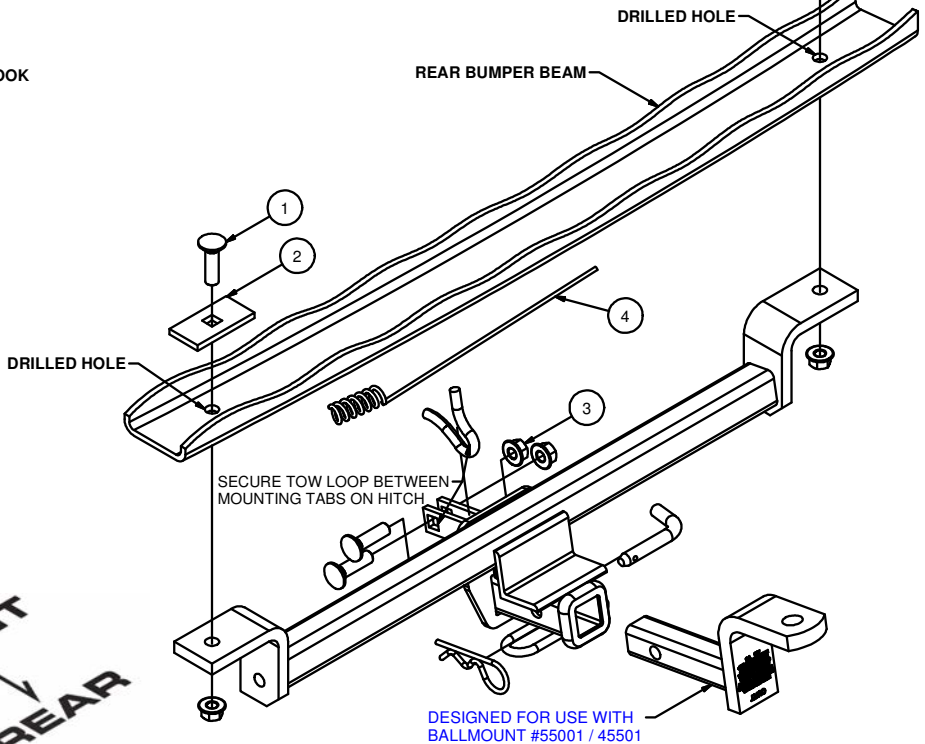

NOTE:
MAY REQUIRE BUMPER FASCIA TRIMMING FOR HITCH CLEARANCE

HITCH WEIGHT: 20 LBS.

INSTALL TIME

PROFESSIONAL: 60 MINUTES

NOVICE (DIY): 120 MINUTES

INSTALL NOTES:

- DRILLING REQUIRED
- FASCIA TAB REMOVAL REQUIRED
- TRIM BUMPER FASCIA AS NEEDED

INSTALLATION STEPS

- 1) Remove (10) plastic fascia fasteners. (re-use later)
- 2) Raise hitch into position by pulling down on fascia and positioning hitch behind bumper cover.
- 3) Center hitch by placing towhook between hitch mounting tabs. Secure using a 1/2" carriage bolt and flange nut.
- 4) Using hitch as a template, mark and drill (2) 1/2" holes through bumper beam.
- 5) Fishwire 1/2" bolts and spacers from ends of bumper beam, through drilled holes and hitch. Secure with flange nuts as shown.
- 6) Torque all 1/2" fasteners to 110 lb-ft.
- 7) Reinstall plastic fascia fasteners removed in step (1).

PERIODICALLY CHECK THIS RECEIVER HITCH TO ENSURE THAT ALL FASTENERS ARE TIGHT AND THAT ALL STRUCTURAL COMPONENTS ARE SOUND.



The **FIRST** Name
in Towing Products™

Trailer Hitches