

11306

CHEVROLET AVEO 5 AND PONTIAC G3 HATCHBACK

GROSS LOAD CAPACITY WHEN USED AS A WEIGHT CARRYING HITCH: 2,000 LBS. TRAILER WEIGHT & 200 LBS. TONGUE WEIGHT.

DO NOT EXCEED VEHICLE MANUFACTURER'S RECOMMENDED TOWING CAPACITY.

WARNING: ALL NON-TRAILER LOADS APPLIED TO THIS PRODUCT MUST BE SUPPORTED BY AUXILIARY STABILIZING STRAPS.

** FAILURE TO PROPERLY SUPPORT NON-TRAILER LOADS WILL VOID PRODUCT WARRANTY**

Parts List			
ITEM	QTY	PART NUMBER	DESCRIPTION
1	3	1/2-13 x 1 3/4	CARRIAGE BOLT
2	3	CM-SP6	.250 x 1.00 x 3.00" SQ. HOLE SPACER
3	3	HFN 1213	HEX FLANGE NUT
4	2	1_2 x 30 FISHWIRE	1/2" x 30" FISHWIRE

TOOLS REQUIRED
3/4" SOCKET
12" EXTENSION
RATCHET
TORQUE WRENCH
DRILL AND 1/2" BIT

FISHWIRE TECHNIQUE

INSERT COILED END OF FISHWIRE TOOL THROUGH HITCH MOUNTING HOLE IN VEHICLE FRAME RAIL AND OUT THE ACCESS HOLE. PASS COILED END OF FISHWIRE THROUGH SPACER AND THREAD BOLT INTO COIL. KINK WIRE TO KEEP SPACER SEPERATE FROM BOLT AS SHOWN. PULL FISHWIRE, SPACER, AND BOLT THROUGH FRAME AND OUT MOUNTING HOLE. USE FISHWIRE TO GUIDE HITCH DURING MOUNTING AND PREVENT LOSS OF BOLT / SPACER INSIDE FRAME RAIL.

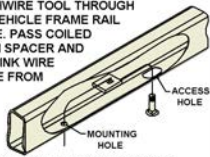

NOTE: SOME VEHICLES MAY FISHWIRE THROUGH END OF FRAME

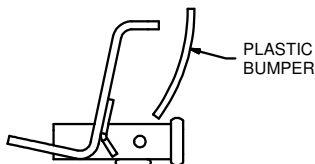

INSTALLED HITCH POSITION

HITCH WEIGHT: 16 LBS.

INSTALL TIME: 60 MINUTES

INSTALL NOTES:

- DRILLING REQUIRED
- FISHWIRE FASTENERS
- REMOVE FASCIA SCREWS

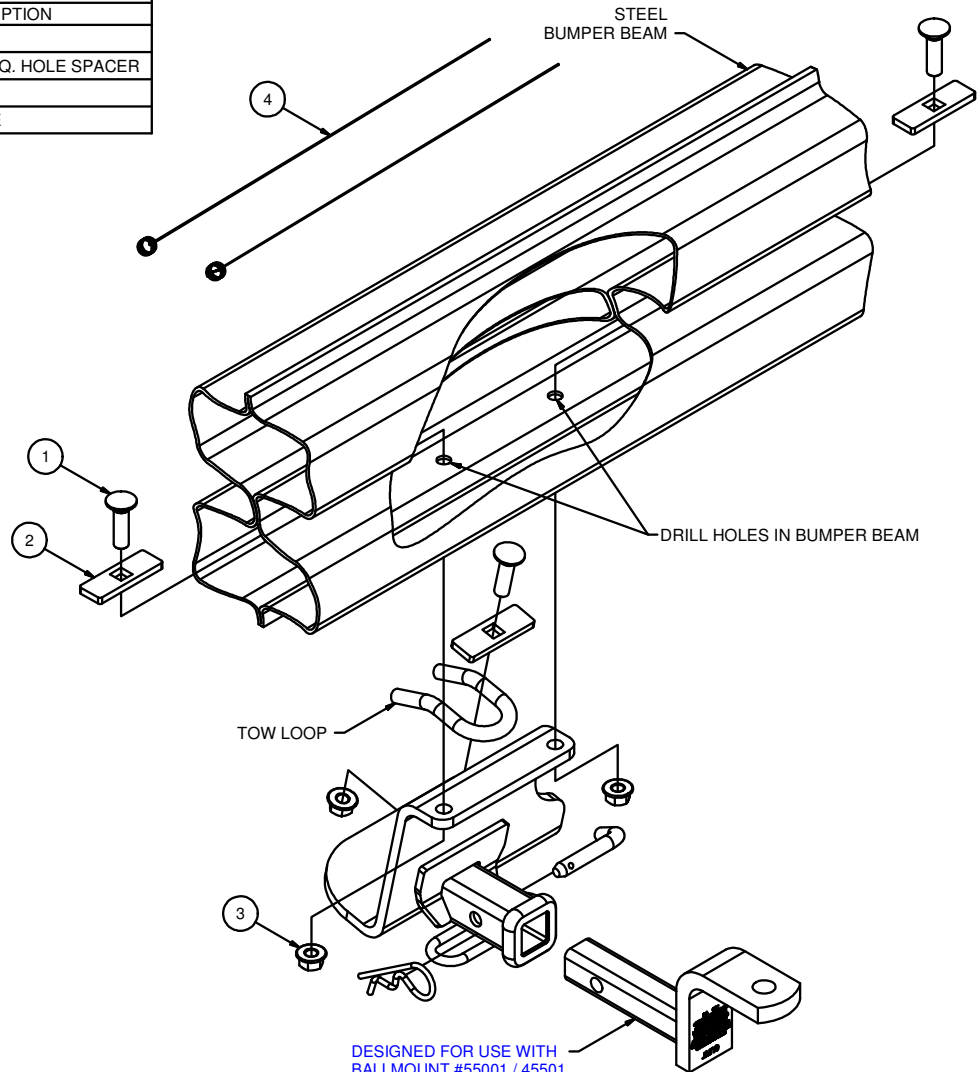

INSTALLATION STEPS

1. Place carriage bolt and spacer into tow loop on vehicle as shown. Raise the hitch into position over the carriage bolt and tight against tow loop. Secure with hex flange nut. (Finger Tight)
2. Remove the bottom rear fascia screws to allow for drill access through the rear holes of the hitch and into the bumper.
3. Rotate the hitch so that it is centered on the vehicle and square to the bumper. Drill holes for 1/2" bolts.
4. Fishwire carriage bolts and spacers through the ends of the bumper, out the drilled holes, and through the hitch mounting holes.
5. Install supplied flange nuts to the carriage bolts fishwired through the bumper.
6. Torque all 1/2" fasteners to 110 lb-ft. Re-install fascia screws removed in Step 2.

PERIODICALLY CHECK THIS RECEIVER HITCH TO ENSURE THAT ALL FASTENERS ARE TIGHT AND THAT ALL STRUCTURAL COMPONENTS ARE SOUND.



The **FIRST** Name
in Towing Products™

Trailer Hitches