

11296

## 00-07 FORD FOCUS WAGON

GROSS LOAD CAPACITY WHEN USED AS A WEIGHT CARRYING HITCH: 2,000 LBS. TRAILER WEIGHT & 200 LBS. TONGUE WEIGHT.

\*\*\*DO NOT EXCEED VEHICLE MANUFACTURER'S RECOMMENDED TOWING CAPACITY.\*\*\*

WARNING: ALL NON-TRAILER LOADS APPLIED TO THIS PRODUCT MUST BE SUPPORTED BY AUXILIARY STABILIZING STRAPS.

\*\* FAILURE TO PROPERLY SUPPORT NON-TRAILER LOADS WILL VOID PRODUCT WARRANTY\*\*

Parts List			
ITEM	QTY	PART NUMBER	DESCRIPTION
1	4	HFN 1213	HEX FLANGE NUT
2	4	CM-SP12	.250 x 1.00 x 2.00" SQUARE HOLE SPACER
3	1	1/2"	FISHWIRE TOOL
4	4	1/2-13 x 1 3/4	CARRIAGE BOLT

#### RUBBER ISOLATOR REMOVAL DIAGRAM

This technique can be used if and Exhaust Hanger Removal Pliers is not available.

Using a 5/8" open end wrench, slide the wrench up to the rubber isolator, cradling the hanger rod as shown. Next place the flat edge of a pry bar between the wrench and the hanger stop or hanger rod. Then simply rotate the pry bar toward the wrench to remove the rubber isolator.

Note: Using a spray lubricant or soapy water on the hanger rod and the rubber isolator helps removal.

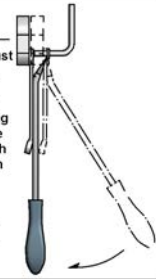

#### FISHWIRE TECHNIQUE

INSERT COILED END OF FISHWIRE TOOL THROUGH HITCH MOUNTING HOLE IN VEHICLE FRAME RAIL AND OUT THE ACCESS HOLE. PASS COILED END OF FISHWIRE THROUGH SPACER AND THREAD BOLT INTO COIL. KINK WIRE TO KEEP SPACER SEPARATE FROM BOLT AS SHOWN. PULL FISHWIRE, SPACER, AND BOLT THROUGH FRAME AND OUT MOUNTING HOLE. USE FISHWIRE TO GUIDE HITCH DURING MOUNTING AND PREVENT LOSS OF BOLT / SPACER INSIDE FRAME RAIL.

\*\*\*NOTE: SOME VEHICLES MAY FISHWIRE THROUGH END OF FRAME\*\*

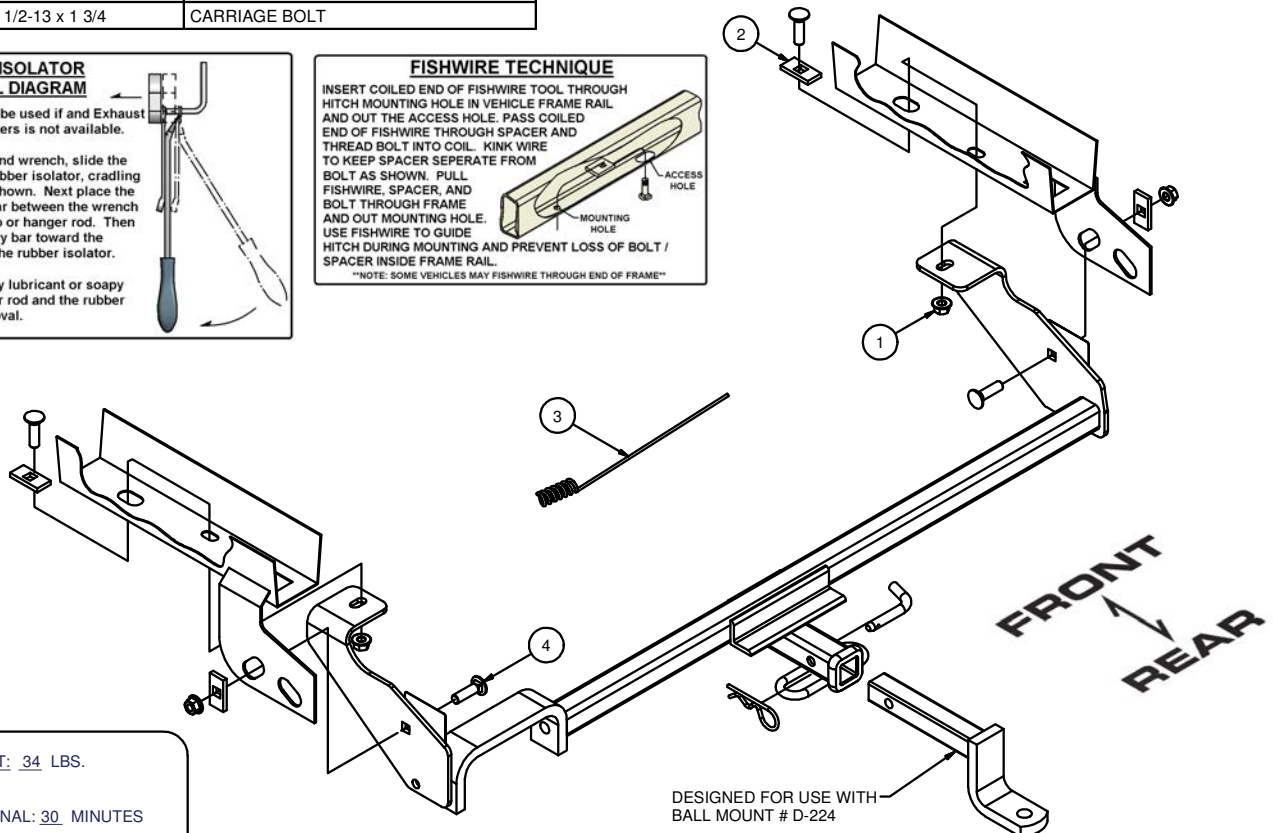
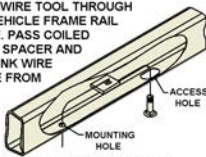

HITCH WEIGHT: .34 LBS.

#### INSTALL TIME

PROFESSIONAL: .30 MINUTES

NOVICE (DIY): .60 MINUTES

#### INSTALL NOTES:

NO DRILLING REQUIRED

## INSTALLATION STEPS

- 1) Slide the rubber exhaust hanger off of exhaust hanger hook.
- 2) Bend corner of muffler heat shield down to increase clearance to access hole on driver's side frame.
- 3) Raise hitch into position and loosely install the rearward fasteners.
- 4) Fishwire carriage bolt and block thru access hole in frame rail, both sides, as shown.
- 5) Install remaining fasteners as shown.
- 6) Reattach rubber exhaust hanger.
- 7) Torque all 1/2" hardware to 110 lb.-ft.

**PERIODICALLY CHECK THIS RECEIVER HITCH TO ENSURE THAT ALL FASTENERS ARE TIGHT AND THAT ALL STRUCTURAL COMPONENTS ARE SOUND.**



The **FIRST** Name  
in Towing Products™

Trailer Hitches