



# 11281 INSTALLATION INSTRUCTIONS



Safety glasses should be worn at all times while installing this product.

YEARS: 2013

MAKE: DODGE

MODEL: DART

STYLE: SEDAN

**WARNING: NEVER EXCEED YOUR VEHICLE MANUFACTURER'S RECOMMENDED TOWING CAPACITY**

**WEIGHT CARRYING:**  
TRAILER WEIGHT: 2000 LBS.  
TONGUE WEIGHT: 200 LBS.





**INSTALLATION TIME: 30 MIN.**  
*THE INSTALL TIME LISTED IS FOR PROFESSIONAL INSTALLERS. IF YOU ARE HESITANT TO UNDERTAKE THIS TASK ON YOUR OWN, CONTACT AN AUTHORIZED CURT INSTALLER FOR ADDITIONAL ASSISTANCE.*

### INSTALLATION REQUIRES:

 <b>SAFETY GLASSES</b>	 <b>3/4" 10 mm SOCKET</b>	 <b>RATCHET</b>
 <b>6" SOCKET EXTENSION</b>	 <b>SCREW DRIVER</b>	 <b>TORQUE WRENCH</b>
 <b>AVIATION SHEARS</b>		

**INSTALLATION TIPS:**  
1. BEFORE YOU BEGIN INSTALLATION, READ ALL INSTRUCTIONS THOROUGHLY.  
2. TO EASE INSTALLATION, 2 PEOPLE MAY BE REQUIRED.  
3. USING PROPER TOOLS WILL GREATLY IMPROVE THE QUALITY OF THE INSTALL AND REDUCE THE TIME REQUIRED.

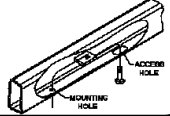
### LEVEL OF DIFFICULTY: MODERATE

EASY	MODERATE	CHALLENGING
 PART REMOVAL	Remove center and side aero shields	
	Remove rubber isolators	
	Fishwiring required	
 TRIM	Trim center aero shield	

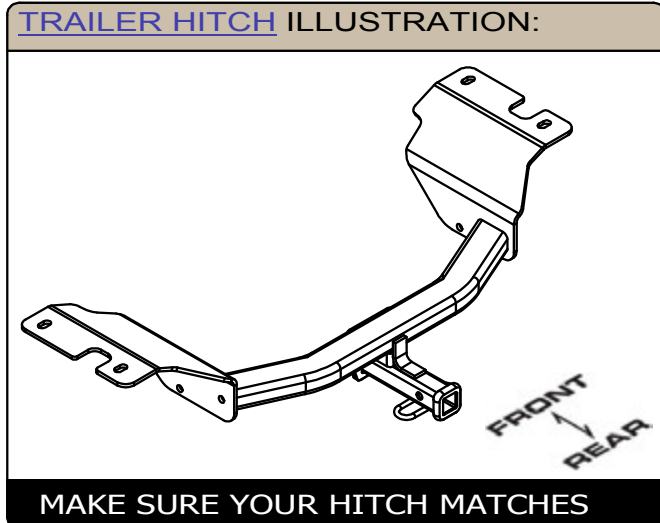

**PERIODICALLY CHECK THIS RECEIVER HITCH TO ENSURE ALL FASTENERS ARE TIGHT AND ALL STRUCTURAL COMPONENTS ARE SOUND**  
CURT Manufacturing LLC. warrants this product to be free of defects in material and/or workmanship at the time of retail purchase by the original purchaser. If the product is found to be defective, Curt Manufacturing LLC. may repair or replace the product at their option, when the product is returned, prepaid, with proof of purchase. Alteration to, misuse of, or improper installation of this product voids the warranty. Curt Manufacturing LLC.'s liability is limited to repair or replacement of products found to be defective, and specifically excludes liability for incidental or consequential loss or damage.

## INSTALLATION WALKTHROUGH:

Parts List			
ITEM	QTY	PART NUMBER	DESCRIPTION
1	4	1_2 FISHWIRE	1/2" FISHWIRE
2	4	1/2-13 x 1 1/2, GR8	CARRIAGE BOLT
3	4	HFN 1213, GR8	HEX FLANGE NUT
4	4	CM-SP6	.250 x 1.00 x 3.00" SPACER

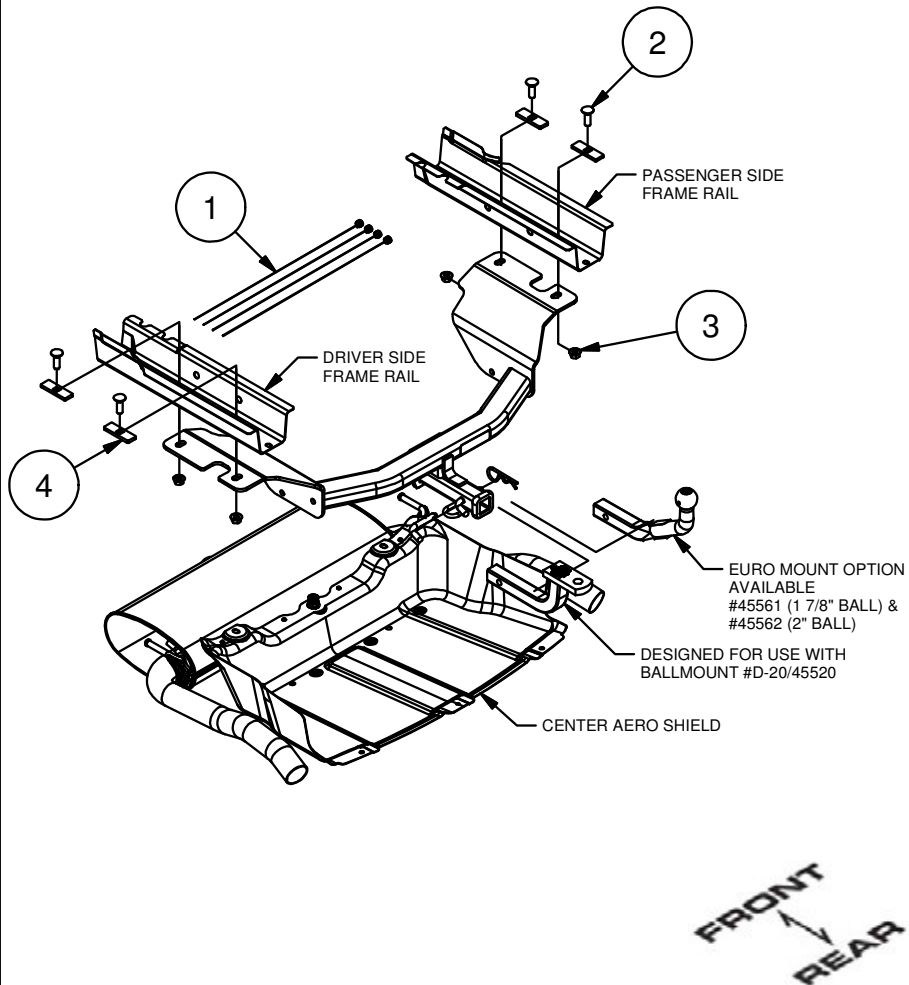

1. Remove center and side aero shields with 10mm socket.

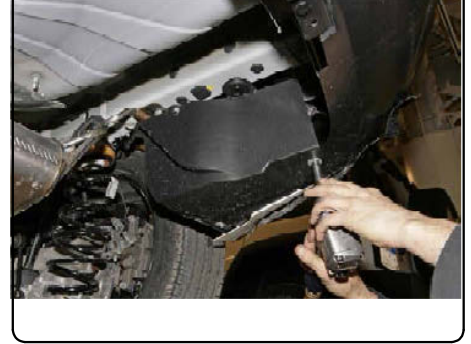
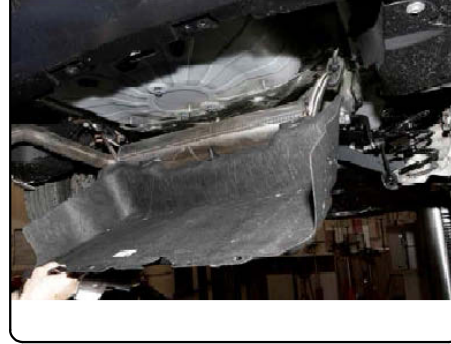

2. Remove rubber exhaust isolators and access covers in each side of frame rail. Remove the forward exhaust isolator while supporting the exhaust from underneath.

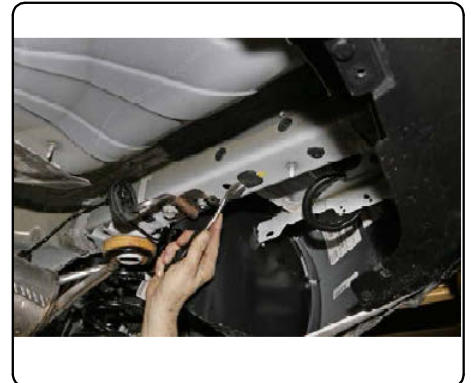
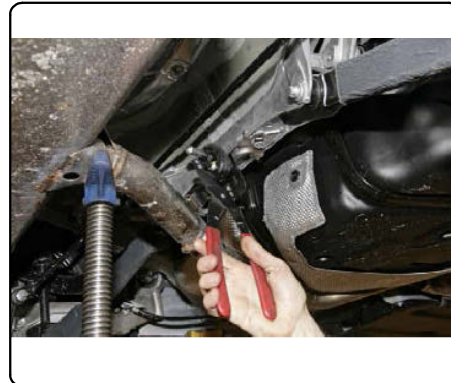

## INSTALLATION WALKTHROUGH:

3. If chrome exhaust outlet accessories are included as vehicle option, remove (3) M10 bolts and remove outlet piece.

Insert bolts through square hole spacer plates and attach fishwire to each. Insert bolt assemblies into rail.

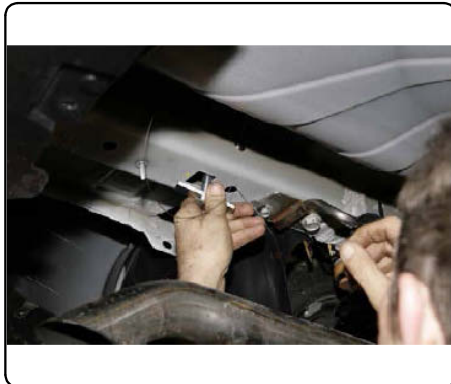
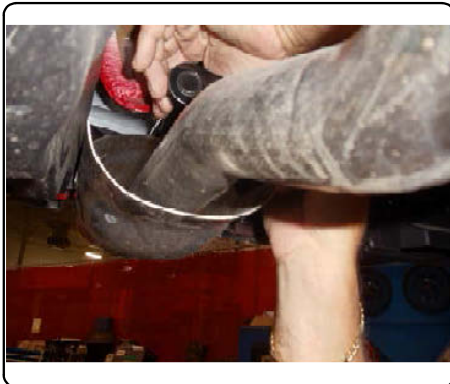

4. Insert fishwires through mounting holes in trailer hitch and align hitch to vehicle frame rails.  
Fishwires can then now be removed and hardware torqued to 110 ft-lb.

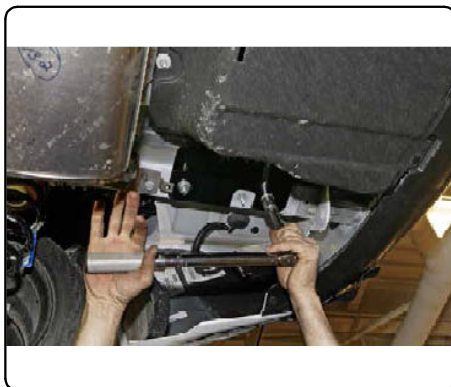

5. Trim center aero shield at marked lines. Once trimmed, re-install center aero shield.



6. Re-install muffler isolators and side aero shields.  
Installation is complete.

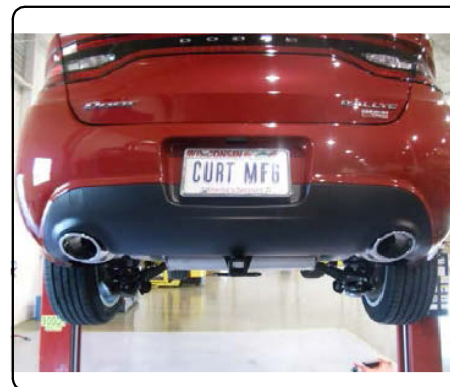
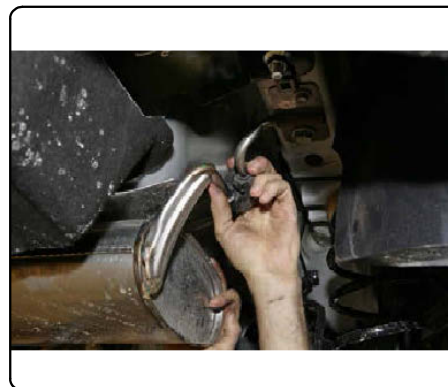

**11281****2013 DODGE DART****3/22/13****GROSS LOAD CAPACITY WHEN USED AS A WEIGHT CARRYING HITCH: 2,000 LBS. TRAILER WEIGHT & 200 LBS. TONGUE WEIGHT.****\*\*\*DO NOT EXCEED VEHICLE MANUFACTURER'S RECOMMENDED TOWING CAPACITY.\*\*\*****WARNING: ALL NON-TRAILER LOADS APPLIED TO THIS PRODUCT MUST BE SUPPORTED BY 18050 STABILIZING STRAPS.****\*\* FAILURE TO PROPERLY SUPPORT NON-TRAILER LOADS WILL VOID PRODUCT WARRANTY\*\***

Parts List				
ITEM	QTY	PART NUMBER	DESCRIPTION	
1	4	1_2 FISHWIRE	1/2" FISHWIRE	
2	4	1/2-13 x 1 1/2, GR8	CARRIAGE BOLT	
3	4	HFN 1213, GR8	HEX FLANGE NUT	
4	4	CM-SP6	.250 x 1.00 x 3.00" SPACER	

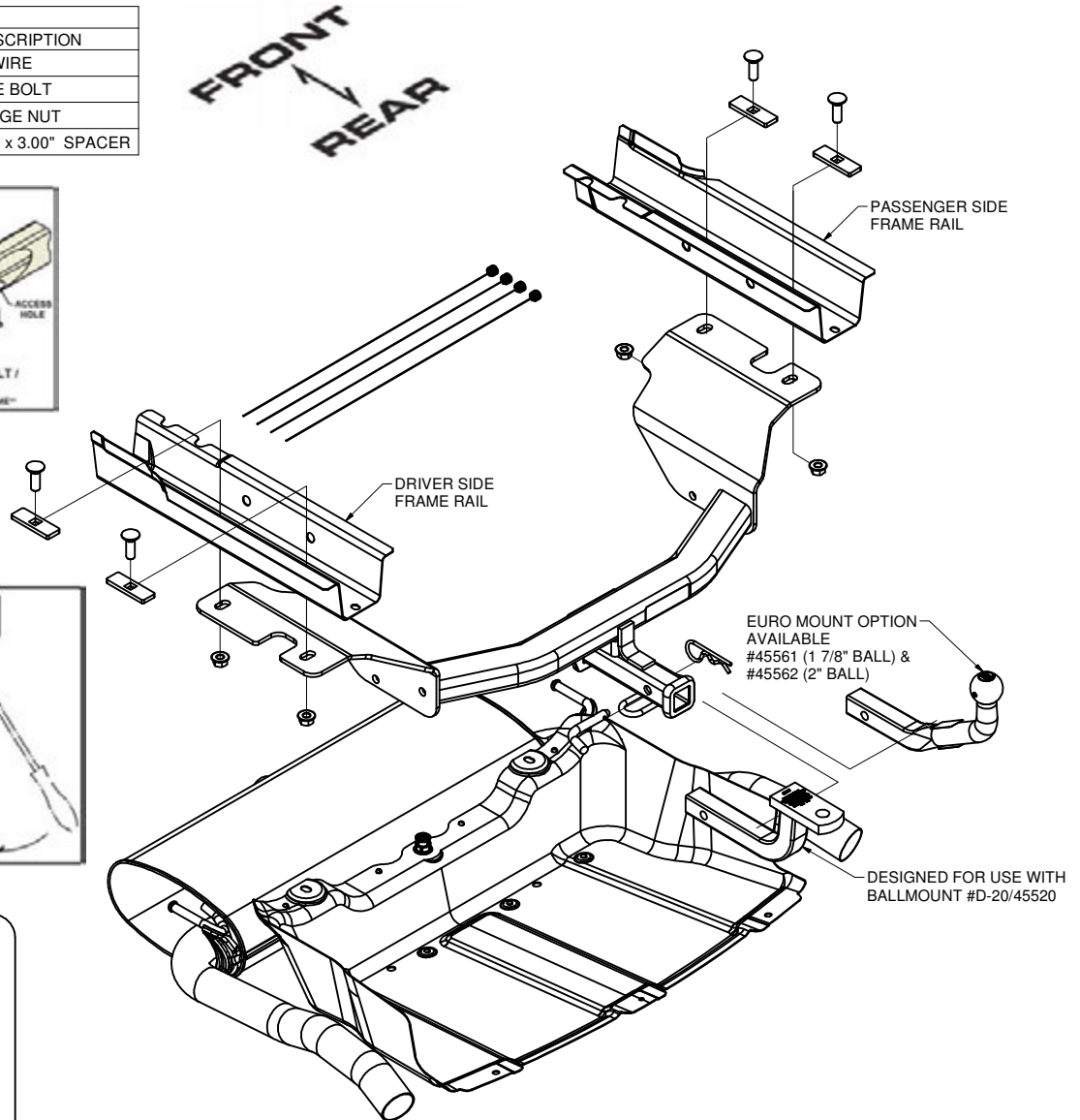
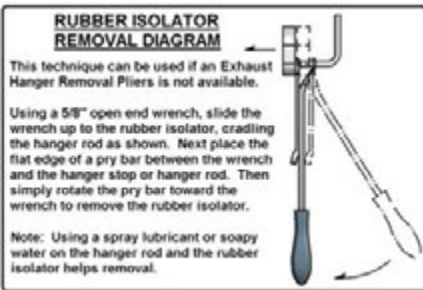
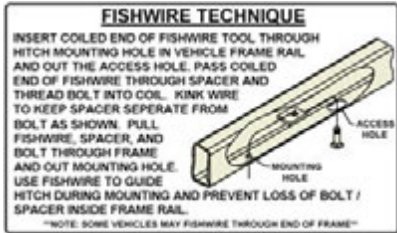
**HITCH WEIGHT: 20.5 LBS.****INSTALL TIME**PROFESSIONAL: 30 MINUTESNOVICE (DIY): 65 MINUTES**INSTALL NOTES:**

- REMOVE VEHICLE COMPONENTS
- REMOVE RUBBER MUFFLER ISOLATORS
- FISHWIRING REQUIRED
- TRIMMING REQUIRED

**INSTALLATION STEPS**

1. Remove center and side aero shields with 10mm socket.
2. Remove rubber exhaust isolators and access covers in each side of frame rail. Remove the forward exhaust isolator while supporting the exhaust from underneath. (See Rubber Isolator Removal Diagram)
3. If chrome exhaust outlet accessories are included as vehicle option, remove (3) M10 bolts and remove outlet piece.  
Insert bolts through square hole spacer plates and attach fishwire to each. Insert bolt assemblies into rail.
4. Insert fishwires through mounting holes in trailer hitch and align hitch to vehicle frame rails.  
Fishwires can then now be removed and hardware torqued to 110 ft-lb.
5. Trim center aero shield at marked lines. Once trimmed, re-install center aero shield.
6. Re-install muffler isolators and side aero shields. Raise exhaust back into position.

**PERIODICALLY CHECK THIS RECEIVER HITCH TO ENSURE THAT ALL FASTENERS ARE TIGHT AND THAT ALL STRUCTURAL COMPONENTS ARE SOUND.**

Curt Manufacturing LLC., warrants this product to be free of defects in material and/or workmanship at the time of retail purchase by the original purchaser. If the product is found to be defective, Curt Manufacturing LLC., may repair or replace the product, at their option, when the product is returned, prepaid, with proof of purchase. Alteration to, misuse of, or improper installation of this product voids the warranty. Curt Manufacturing LLC.'s liability is limited to repair or replacement of products found to be defective, and specifically excludes liability for incidental or consequential loss or damage.