



Safety glasses should be worn at all times while installing this product.

YEARS: 2011-Present

MAKE: Chevrolet

MODEL: Camaro

STYLE: Convertible





WARNING: NEVER EXCEED YOUR VEHICLE MANUFACTURER'S RECOMMENDED TOWING CAPACITY

WEIGHT CARRYING:
TRAILER WEIGHT: 2000 LBS.
TONGUE WEIGHT: 200 LBS.

INSTALLATION TIME: 20 MIN.

THE INSTALL TIME LISTED IS FOR PROFESSIONAL INSTALLERS. IF YOU ARE HESITANT TO UNDERTAKE THIS TASK ON YOUR OWN, CONTACT AN AUTHORIZED CURT INSTALLER FOR ADDITIONAL ASSISTANCE.



INSTALLATION REQUIRES:

 SAFETY GLASSES	 SCREW DRIVER	 RATCHET
 15mm 3/4" SOCKET	 TORQUE WRENCH	

INSTALLATION TIPS:

- BEFORE YOU BEGIN INSTALLATION, READ ALL INSTRUCTIONS THOROUGHLY.
- TO EASE INSTALLATION, 2 PEOPLE MAY BE REQUIRED.
- USING PROPER TOOLS WILL GREATLY IMPROVE THE QUALITY OF THE INSTALL AND REDUCE THE TIME REQUIRED.
- NEED HELP OR HAVE SOME QUESTIONS? CALL TECHNICAL SUPPORT AT 800.798.0813

LEVEL OF DIFFICULTY: MODERATE

<i>EASY</i>	<i>MODERATE</i>	<i>CHALLENGING</i>
 PART REMOVAL	UNDERBODY COVER REMOVAL REQUIRED	
	NO DRILLING REQUIRED	

VEHICLE PHOTO:



REPRESENTATIVE PHOTO

TRAILER HITCH ILLUSTRATION:

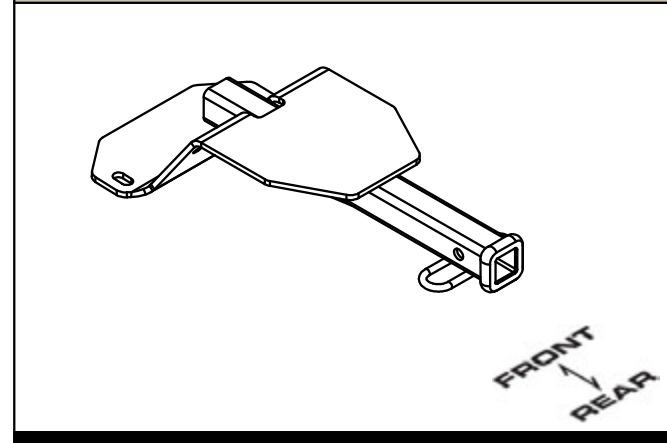

MAKE SURE YOUR HITCH MATCHES

PERIODICALLY CHECK THIS RECEIVER HITCH TO ENSURE ALL FASTENERS ARE TIGHT AND ALL STRUCTURAL COMPONENTS ARE SOUND

CURT Manufacturing LLC. warrants this product to be free of defects in material and/or workmanship at the time of retail purchase by the original purchaser. If the product is found to be defective, Curt Manufacturing LLC. may repair or replace the product at their option, when the product is returned, prepaid, with proof of purchase. Alteration to, misuse of, or improper installation of this product voids the warranty. Curt Manufacturing LLC.'s liability is limited to repair or replacement of products found to be defective, and specifically excludes liability for incidental or consequential loss or damage.

INSTALLATION WALKTHROUGH:

Parts List			
ITEM	QTY	PART NUMBER	DESCRIPTION
1	2	1/2-13 x 1 3/4	CARRIAGE BOLT
2	2	HFN 1213	HEX FLANGE NUT
3	2	CM-SP28	.250 x 3.00 x 4.00" SPACER
4	2	1_2 FISHWIRE	1/2" FISHWIRE
5	8	3/8"	WASHER

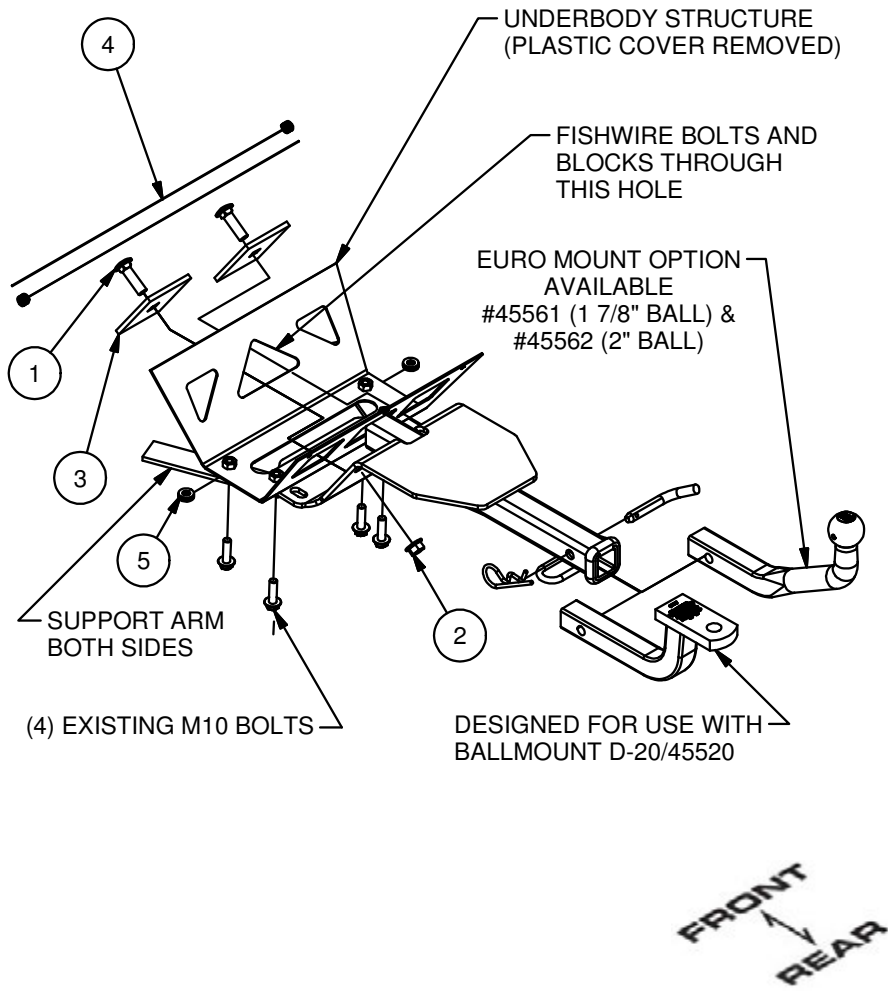

1. Remove plastic underbody cover by carefully removing 5 plastic retaining clips. Return cover and clips to vehicle owner.

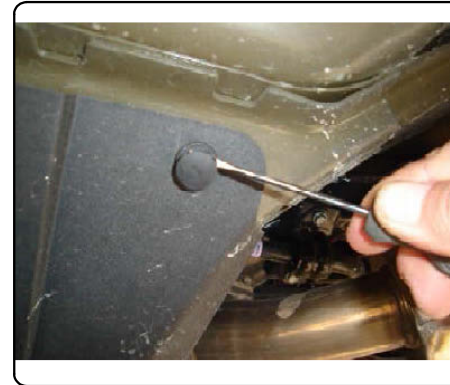

2. Remove (4) bolts which attach support arms to underbody structure. If present, remove washers used as spacers between support arms and underbody structure. Retain bolts for hitch installation. Return washers to vehicle owner.



INSTALLATION WALKTHROUGH:

3. Place (4) 3/8" washers between the support arm and the underbody structure, both sides. Align the washers with the forward most holes and loosely secure using the existing M10 bolts removed in Step 2. Raise hitch into position as shown, with bottom horizontal flange sandwiched between support arms and underbody structure. Install M10 bolts removed in Step 2, as shown, finger tight.



4. Push hitch forward against underbody structure. Fishwire carriage bolts and large spacer blocks through holes in front face of underbody structure. Secure with 1/2" flange nuts.



5. Torque all 1/2" fasteners to 110 lb-ft. and all M10 fasteners to 48 lb-ft.



Install is complete



11222 Chevrolet Camaro Convertible (Will NOT fit with Ground Effects)

GROSS LOAD CAPACITY WHEN USED AS A WEIGHT CARRYING HITCH: 2000 LBS. TRAILER WEIGHT & 200 LBS. TONGUE WEIGHT.

*****DO NOT EXCEED VEHICLE MANUFACTURER'S RECOMMENDED TOWING CAPACITY.*****

WARNING: ALL NON-TRAILER LOADS APPLIED TO THIS PRODUCT MUST BE SUPPORTED BY 18050 STABILIZING STRAPS.

**** FAILURE TO PROPERLY SUPPORT NON-TRAILER LOADS WILL VOID PRODUCT WARRANTY****

Parts List			
ITEM	QTY	PART NUMBER	DESCRIPTION
1	2	1/2-13 x 1 3/4	CARRIAGE BOLT
2	2	HFN 1213	HEX FLANGE NUT
3	2	CM-SP28	.250 x 3.00 x 4.00" SPACER
4	2	1_2 FISHWIRE	1/2" FISHWIRE
5	8	3/8"	WASHER

FRONT
↓
REAR

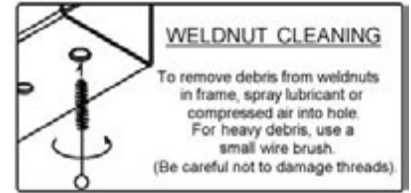

TOOLS REQUIRED
SCREW DRIVER
RATCHET
TORQUE WRENCH
15mm SOCKET
3/4" SOCKET

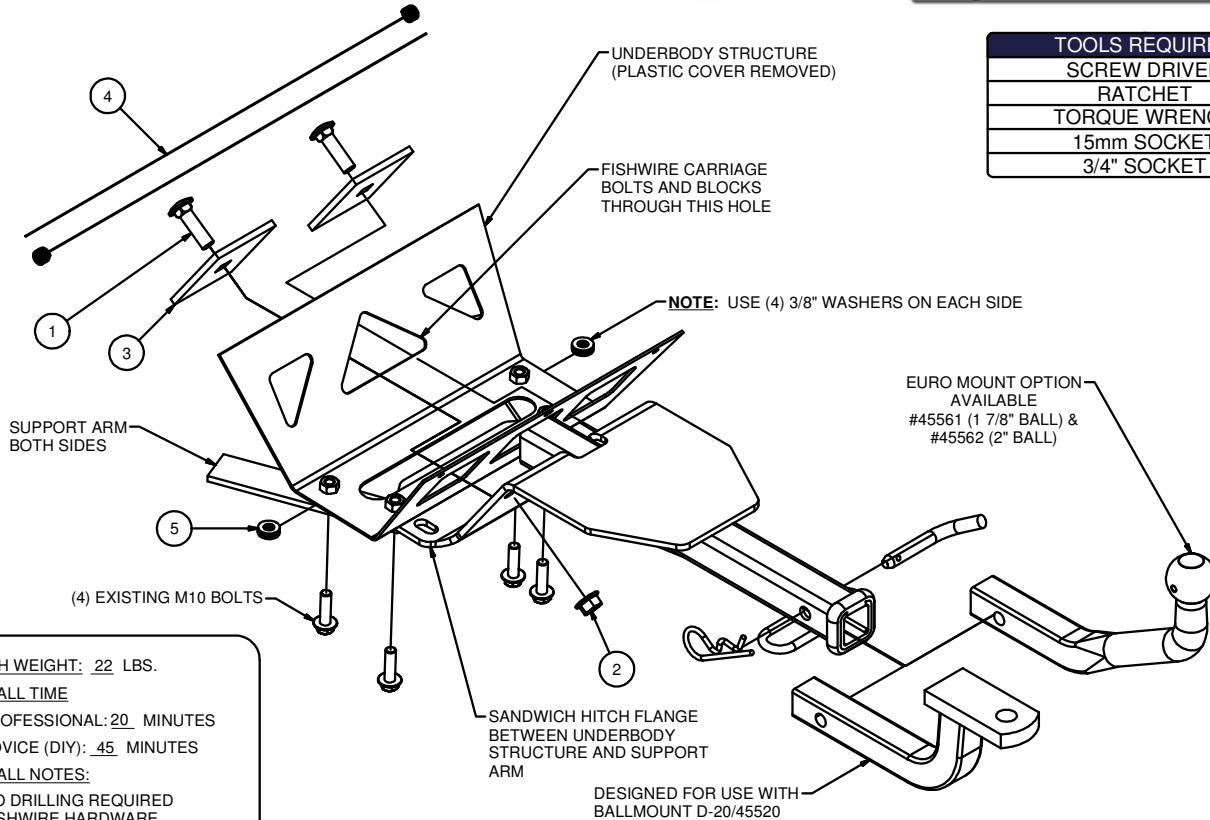

HITCH WEIGHT: 22 LBS.

INSTALL TIME

PROFESSIONAL: 20 MINUTES

NOVICE (DIY): 45 MINUTES

INSTALL NOTES:

- NO DRILLING REQUIRED
- FISHWIRE HARDWARE

INSTALLATION STEPS

1. Remove plastic underbody cover by carefully removing (5) plastic retaining clips. Return cover and clips to vehicle owner.
2. Remove (4) bolts which attach support arms to underbody structure. If present, remove washers used as spacers between support arms and underbody structure. Retain bolts for hitch installation. Return washers to vehicle owner.
3. Place (4) 3/8" washers between the support arm and the underbody structure, both sides. Align the washers with the forward most holes and loosely secure using the existing M10 bolts removed in Step 2.
4. Raise hitch into position as shown, with bottom horizontal flange sandwiched between support arms and underbody structure. Install M10 bolts removed in Step 2, as shown, finger tight.
5. Push hitch forward against underbody structure. Fishwire carriage bolts and large spacer blocks through holes in front face of underbody structure. Secure with 1/2" flange nuts.
6. Torque all 1/2" fasteners to 110 ft.-lbs. Torque all M10 fasteners to 48 ft.-lbs.

PERIODICALLY CHECK THIS RECEIVER HITCH TO ENSURE THAT ALL FASTENERS ARE TIGHT AND THAT ALL STRUCTURAL COMPONENTS ARE SOUND.

Curt Manufacturing LLC., warrants this product to be free of defects in material and/or workmanship at the time of retail purchase by the original purchaser. If the product is found to be defective, Curt Manufacturing LLC., may repair or replace the product, at their option, when the product is returned, prepaid, with proof of purchase. Alteration to, misuse of, or improper installation of this product voids the warranty. Curt Manufacturing LLC.'s liability is limited to repair or replacement of products found to be defective, and specifically excludes liability for incidental or consequential loss or damage.