

11204 / 247387

01-05 HONDA CIVIC

GROSS LOAD CAPACITY WHEN USED AS A WEIGHT CARRYING HITCH: 2,000 LBS. TRAILER WEIGHT & 200 LBS. TONGUE WEIGHT.
*****DO NOT EXCEED VEHICLE MANUFACTURER'S RECOMMENDED TOWING CAPACITY.*****

Parts List			
ITEM	QTY	PART NUMBER	DESCRIPTION
1	1	CM-438-FW	7/16" FISHWIRE TOOL
2	1	1/2-13 x 2"	HEX BOLT
3	1	1_2 - 13	NYLOCK HEX NUT
4	2	7/16-14 x 1 1/2	CARRIAGE BOLT
5	2	7/16 WASHER	WASHER
6	2	7/16 LOCK WASHER	HELICAL LOCK WASHER
7	2	7/16-14	HEX NUT
8	2	CM-SP108	2.00 X 0.88 X .125 SPACER
9	1	CM-SP128	.375 x 1.50" SPACER

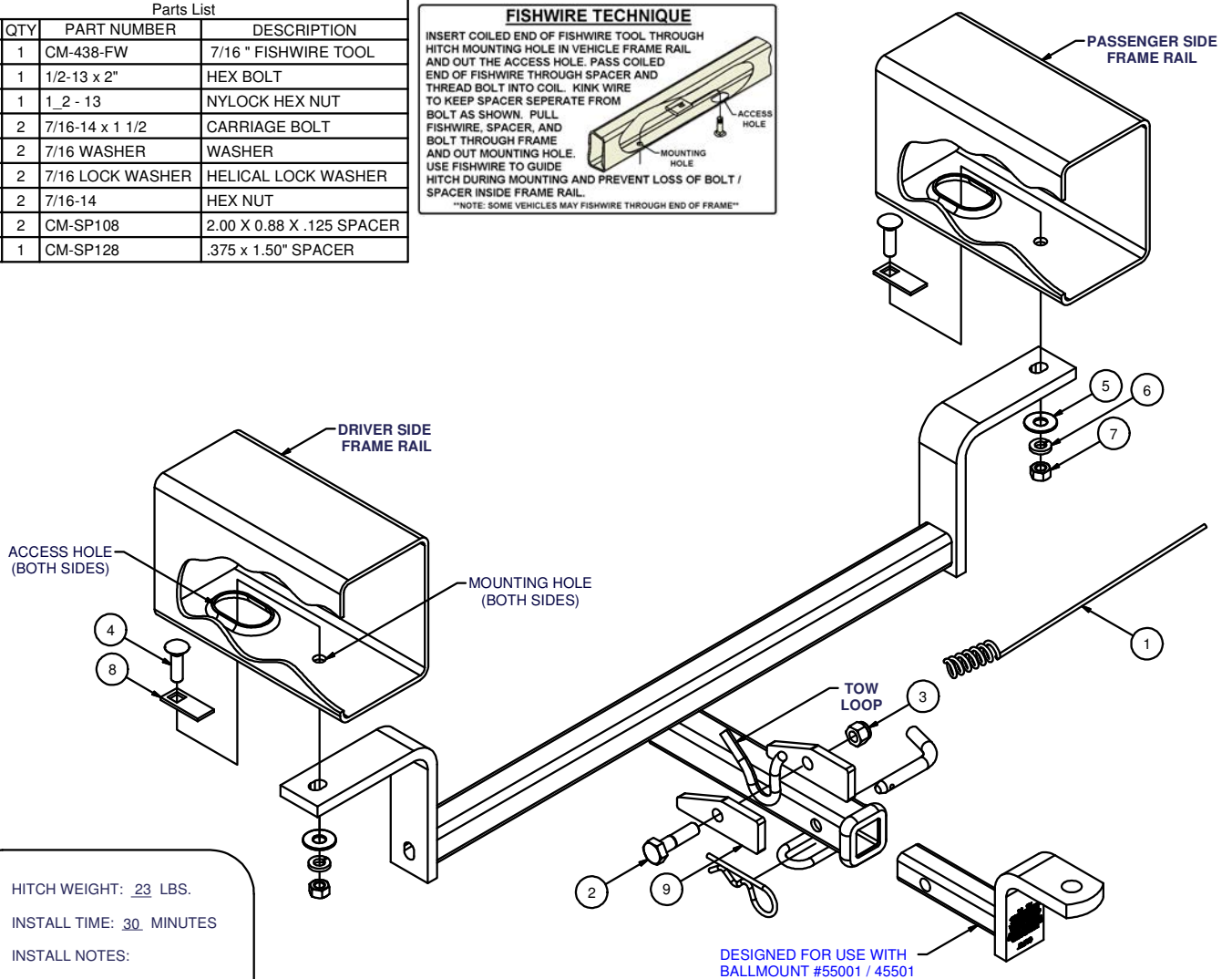
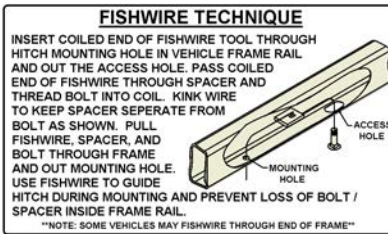

HITCH WEIGHT: 23 LBS.
 INSTALL TIME: 30 MINUTES
 INSTALL NOTES:
NO DRILLING REQUIRED

INSTALLATION STEPS

- 1) General fit: This hitch mounts to the car's central tow loop under the bumper and to existing holes in the left and right frame rails.
- 2) Hold the hitch in position at tow loop and the frame rails to identify the correct frame mounting holes. Fishwire 7/16" carriage bolts with CM-SP108 spacers into position as shown. Use the larger access hole forward of the mounting holes on the bottom of the frame rails.
- 3) Raise hitch to the carriage bolts in the frame rails and install flat washers, lock washers, and hex nuts to each side as shown.
- 4) Use 1/2" fasteners to mount the hitch to the car's tow loop. The larger spacer plate fits to the opposite side of tow loop.
- 5) Torque all 7/16" fasteners to 70 lb-ft, and all 1/2" fasteners to 110 lb-ft

PERIODICALLY CHECK THIS RECEIVER HITCH TO ENSURE THAT ALL FASTENERS ARE TIGHT AND THAT ALL STRUCTURAL COMPONENTS ARE SOUND.



The **FIRST** Name in Towing Products™

Trailer Hitches