

11192

AUDI A3 SPORT BACK 5 DOOR HATCH

GROSS LOAD CAPACITY WHEN USED AS A WEIGHT CARRYING HITCH: 2000 LBS. TRAILER WEIGHT & 200 LBS. TONGUE WEIGHT.

DO NOT EXCEED VEHICLE MANUFACTURER'S RECOMMENDED TOWING CAPACITY.

WARNING: ALL NON-TRAILER LOADS APPLIED TO THIS PRODUCT MUST BE SUPPORTED BY AUXILIARY STABILIZING STRAPS.

** FAILURE TO PROPERLY SUPPORT NON-TRAILER LOADS WILL VOID PRODUCT WARRANTY**

Parts List			
ITEM	QTY	PART NUMBER	DESCRIPTION
1	2	CM-11192-NPW	NUT PLATE WELDMENT
2	4	1/2 - 13 x 1 1/2	HEX BOLT
3	4	1/2"	CONICAL TOOTHED WASHER
4	2	CM-SP18	.250 x 1.00 x 2.00" SQUARE HOLE SPACER
5	2	3/8 - 16 x 1 3/4	CARRIAGE BOLT
6	2	HFN3816	HEX FLANGE NUT
7	2	3/8"	CONICAL TOOTHED WASHER

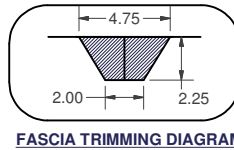

FASCIA TRIMMING DIAGRAM

RUBBER ISOLATOR REMOVAL DIAGRAM

This technique can be used if and Exhaust Hanger Removal Pliers is not available.

Using a 5/8" open end wrench, slide the wrench up to the rubber isolator, cradling the hanger rod as shown. Next place the flat edge of a pry bar between the wrench and the hanger stop or hanger rod. Then simply rotate the pry bar toward the wrench to remove the rubber isolator.

Note: Using a spray lubricant or soapy water on the hanger rod and the rubber isolator helps removal.

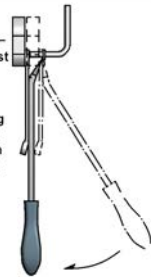

DRIVER SIDE BUMPER SUPPORT RAIL

USE HITCH AS A TEMPLATE, DRILL TWO 1/2" HOLES (BOTH SIDES)

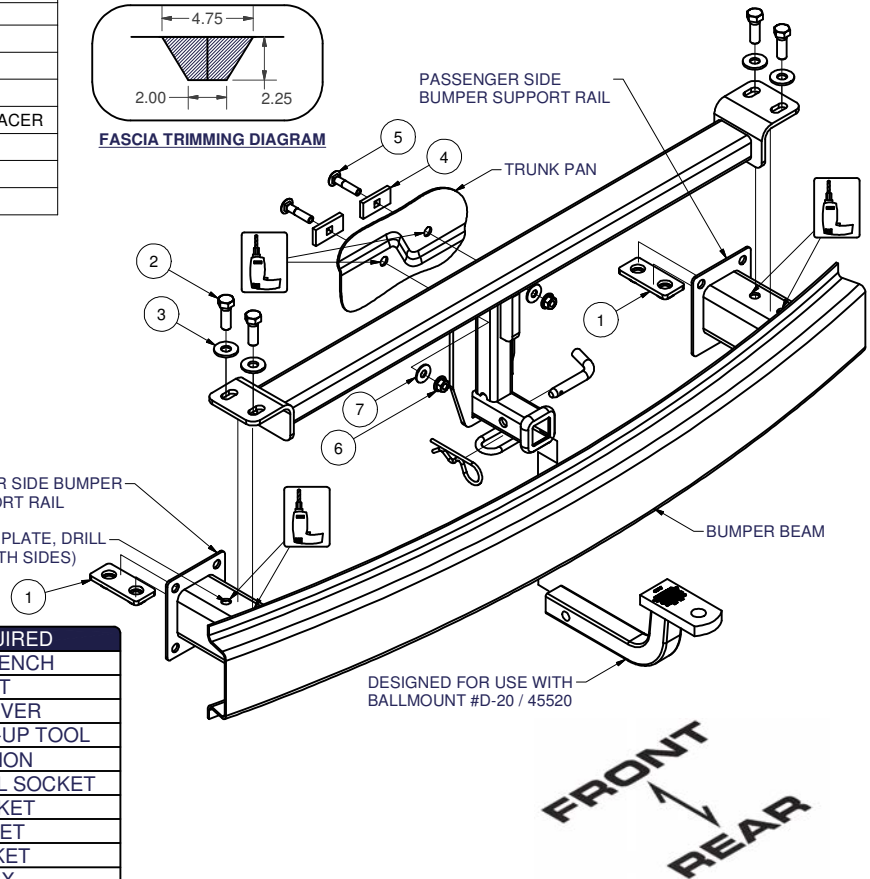

HITCH WEIGHT: 30 LBS.

INSTALL TIME

PROFESSIONAL: 150 MINUTES

NOVICE (DIY): 300 MINUTES

INSTALL NOTES:

- REMOVE SPARE TIRE
- REMOVE REAR BUMPER
- DRILLING REQUIRED
- REMOVE TAIL LIGHTS
- FASCIA TRIMMING REQUIRED
- MAY REQUIRE EXHAUST AND HEAT SHIELD LOWERING

TOOLS REQUIRED

- TORQUE WRENCH
- RATCHET
- SCREW DRIVER
- MAGNETIC PICK-UP TOOL
- 9" EXTENSION
- 10mm DEEP WELL SOCKET
- 13mm SOCKET
- 3/4" SOCKET
- 9/16" SOCKET
- T-25 TORX

INSTALLATION STEPS

- To remove the rear bumper, remove (3) torx screws from inside each wheel well. Remove both tail lights by using a socket through the port on the inside of trunk. Rotate light out of place **carefully**, so the tabs on the back side stay intact (rotate then pull straight out from the side to remove lens). Remove 2 torx screws from beneath each tail light (one short black, one long silver). Remove the 2 torx screws from the underside of the bumper. Using a screwdriver pop off the plastic covers inside the trunk to access (2) hex nuts using a 10mm deep socket. **Note:** Be sure the socket you use is deep enough so it will not bottom out on the post. Use a magnetic arm to catch the nuts. Detach the bumper cover from the side of the car, then pull straight backwards to remove.
- Loosen bumper beam to place hitch into position above bumper beam support rails, and back against the trunk pan. Using the hitch as a template, mark and drill holes into bumper beam support rails (through top side only) and holes into trunk pan.
- Remove bumper beam from vehicle, (6) hex bolts. May need to lower exhaust (2 hangers) and heat shield for access to trunk pan mounting holes. Clear spare tire well of ALL contents before drilling.
- Install hitch onto bumper beam support rails by inserting hex bolts through hitch into frame rail. Hold the supplied nut plates inside frame and tighten using 3/4" ratchet on hex bolt head. Tighten securely. (both sides)
- Re-install bumper beam onto vehicle. Install carriage bolts from the underside of the spare tire well outward. Install remaining hex head flange nuts with conical tooth washers.
- Torque all 1/2" fasteners to 110 lb-ft and all 3/8" fasteners to 45 lb-ft.
- Trim bumper fascia as required for proper fit (see diagram above).
- Re-install heat shield, exhaust, bumper fascia (in reverse order of removal), and tail lights (be sure lights work correctly after re-assembled).

PERIODICALLY CHECK THIS RECEIVER HITCH TO ENSURE THAT ALL FASTENERS ARE TIGHT AND THAT ALL STRUCTURAL COMPONENTS ARE SOUND.



The **FIRST** Name
in Towing Products™

Trailer Hitches