



Safety glasses should be worn at all times while installing this product.

YEARS: 2012-CURRENT

MAKE: MAZDA

MODEL: MAZDA 5

STYLE: VAN

WARNING: NEVER EXCEED YOUR VEHICLE MANUFACTURER'S RECOMMENDED TOWING CAPACITY

WEIGHT CARRYING:
 TRAILER WEIGHT: 2,000 LBS.
 TONGUE WEIGHT: 200 LBS.

INSTALLATION TIME: 45 MIN.

THE INSTALL TIME LISTED IS FOR PROFESSIONAL INSTALLERS. IF YOU ARE HESITANT TO UNDERTAKE THIS TASK ON YOUR OWN, CONTACT AN AUTHORIZED CURT INSTALLER FOR ADDITIONAL ASSISTANCE.



INSTALLATION REQUIRES:

 RATCHET	 TORQUE WRENCH	 10mm 11/16" SOCKET
 5" SOCKET EXTENSION	 AVIATION SHEARS	 DIE GRINDER

INSTALLATION TIPS:

- BEFORE YOU BEGIN INSTALLATION, READ ALL INSTRUCTIONS THOROUGHLY.
- TO EASE INSTALLATION, 2 PEOPLE MAY BE REQUIRED.
- USING PROPER TOOLS WILL GREATLY IMPROVE THE QUALITY OF THE INSTALL AND REDUCE THE TIME REQUIRED.

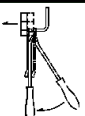
LEVEL OF DIFFICULTY: MODERATE

EASY	MODERATE	HARD
	- LOWER EXHAUST	
	- ENLARGE ACCESS HOLES	
	- TRIM HEAT SHIELD	

VEHICLE PHOTO:

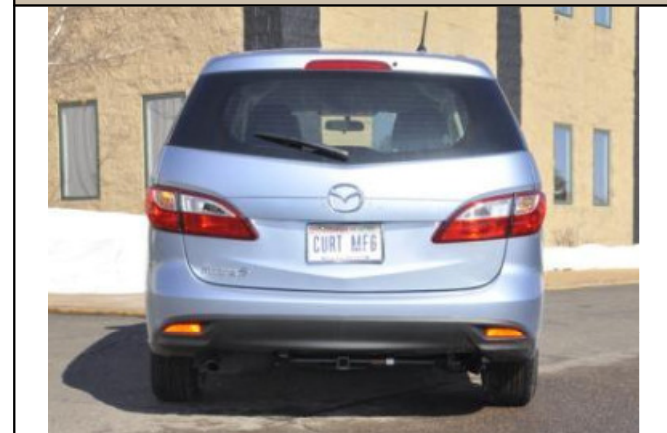

REPRESENTATIVE PHOTO

TRAILER HITCH ILLUSTRATION:

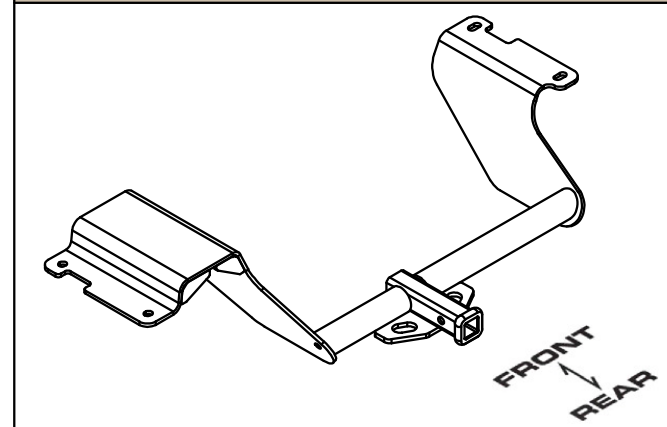

MAKE SURE YOUR HITCH MATCHES

PERIODICALLY CHECK THIS RECEIVER HITCH TO ENSURE ALL FASTENERS ARE TIGHT AND ALL STRUCTURAL COMPONENTS ARE SOUND

CURT Manufacturing LLC warrants this product to be free of defects in material and/or workmanship at the time of retail purchase by the original purchaser. If the product is found to be defective, Curt Manufacturing LLC. may repair or replace the product at their option, when the product is returned, prepaid, with proof of purchase. Alteration to, misuse of, or improper installation of this product voids the warranty. Curt Manufacturing LLC's liability is limited to repair or replacement of products found to be defective, and specifically excludes liability for incidental or consequential loss or damage.

INSTALLATION WALKTHROUGH:

Parts List			
ITEM	QTY	PART NUMBER	DESCRIPTION
1	4	7/16-14	HEX FLANGE NUT
2	4	CM-SP7	.250 x 1.00 x 2.00" SQUARE HOLE SPACER
3	4	7/16-14 x 1 1/4	CARRIAGE BOLT
4	2	7_16 FISHWIRE	7/16" FISHWIRE

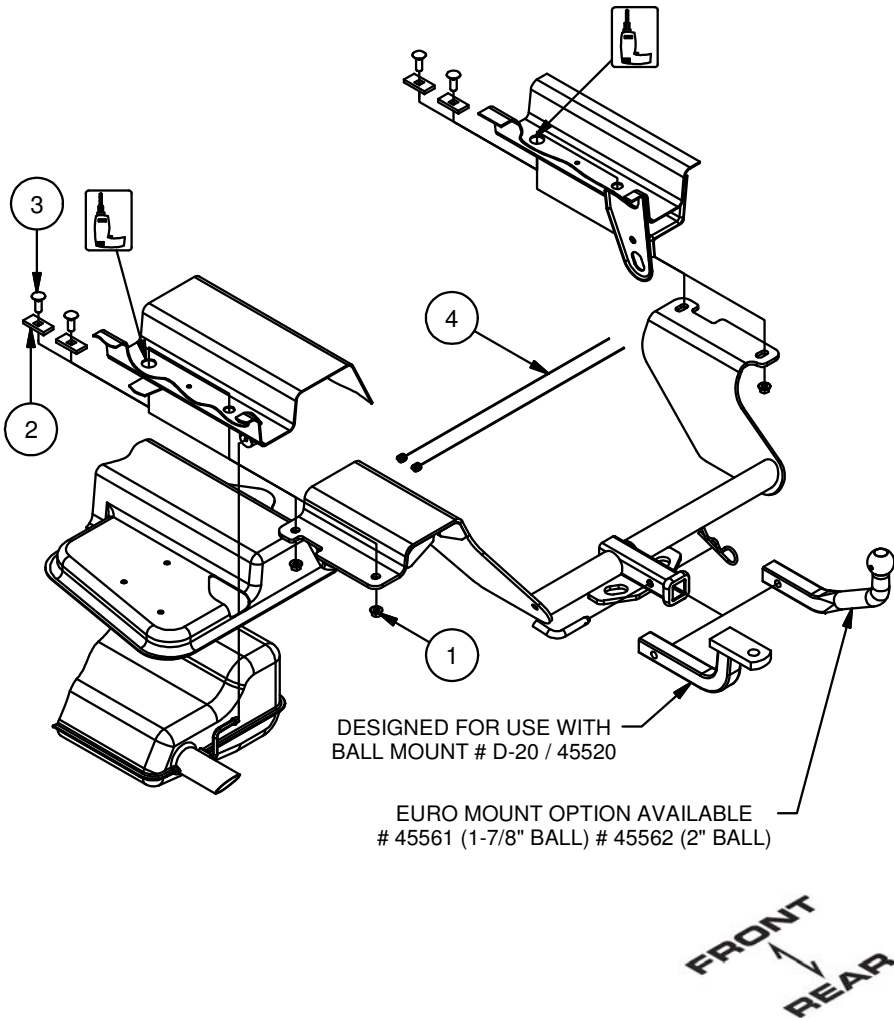

1. Lower exhaust by removing (3) rubber exhaust hangers.

RUBBER ISOLATOR REMOVAL DIAGRAM

This technique can be used if an Exhaust Hanger Removal Pliers is not available.

Using a 5/8" open end wrench, slide the wrench up to the rubber isolator, cradling the hanger rod as shown. Next place the flat edge of a pry bar between the wrench and the hanger stop or hanger rod. Then simply rotate the pry bar toward the wrench to remove the rubber isolator.

Note: Using a spray lubricant or soapy water on the hanger rod and the rubber isolator helps removal.



2. Remove the heat shield by removing (6) fasteners.



INSTALLATION WALKTHROUGH:

3. Enlarge the forward most access holes to allow 7/16-14 carriage bolts and SP7 spacers to pass through.
Note: If present, remove any tape covering holes in the frame rails.



4. Fishwire 7/16-14 carriage bolts and SP7 spacers through the access holes and out the rear-most holes in the frame rails, both sides.

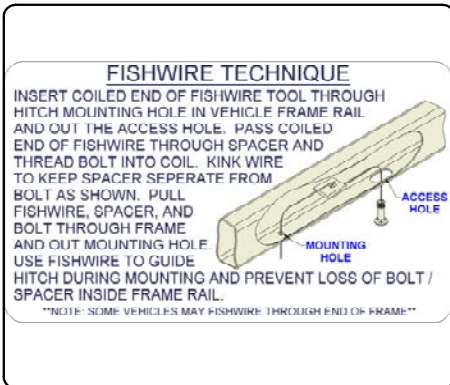

5. Reverse fishwire 7/16-14 carriage bolts and SP7 spacers in the access holes, both sides.

REVERSE PULL FISHWIRE TECHNIQUE

ATTACH FISHWIRE TO CARRIAGE BOLT AND SLIDE SPACER ONTO FISHWIRE. PUSH THE BOLT THRU THE HOLE FOLLOWED BY THE SPACER (AS SHOWN). PULL BOLT BACK INTO POSITION, PROTRUDING FROM THE FRAME.

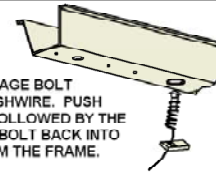

6. Mark heat shield for trimming and confirm the fit. Trim heat shield and reattach using (4) fasteners removed in Step (2).

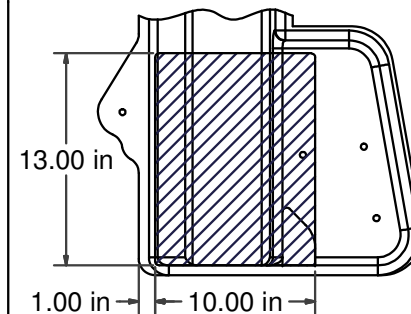

HEAT SHIELD TRIM DIAGRAM

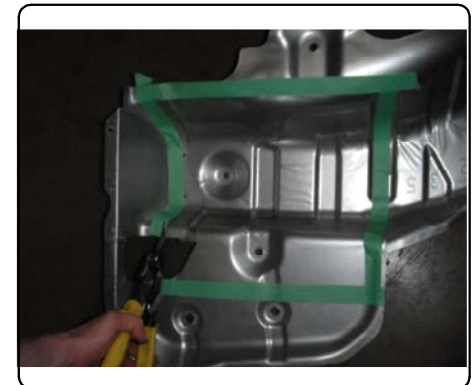

INSTALLATION WALKTHROUGH:

7. Raise hitch into position and secure using 7/16-14 flange nuts. Torque all 7/16" hardware to 70 ft-lbs.



8. Raise exhaust and reattach (3) rubber exhaust hangers



INSTALLATION COMPLETE



11127

MAZDA 5

GROSS LOAD CAPACITY WHEN USED AS A WEIGHT CARRYING HITCH: 2,000 LBS. TRAILER WEIGHT & 200 LBS. TONGUE WEIGHT.

*****DO NOT EXCEED VEHICLE MANUFACTURER'S RECOMMENDED TOWING CAPACITY.*****

WARNING: ALL NON-TRAILER LOADS APPLIED TO THIS PRODUCT MUST BE SUPPORTED BY 18050 STABILIZING STRAPS.

**** FAILURE TO PROPERLY SUPPORT NON-TRAILER LOADS WILL VOID PRODUCT WARRANTY****

Parts List			
ITEM	QTY	PART NUMBER	DESCRIPTION
1	4	7/16-14	HEX FLANGE NUT
2	4	CM-SP7	.250 x 1.00 x 2.00" SQUARE HOLE SPACER
3	4	7/16-14 x 1 1/4	CARRIAGE BOLT
4	2	7_16 FISHWIRE	7/16" FISHWIRE

TOOLS REQUIRED
RATCHET
TORQUE WRENCH
10mm SOCKET
11/16" SOCKET
5" EXTENSION
DIE GRINDER
AVIATION SHEARS

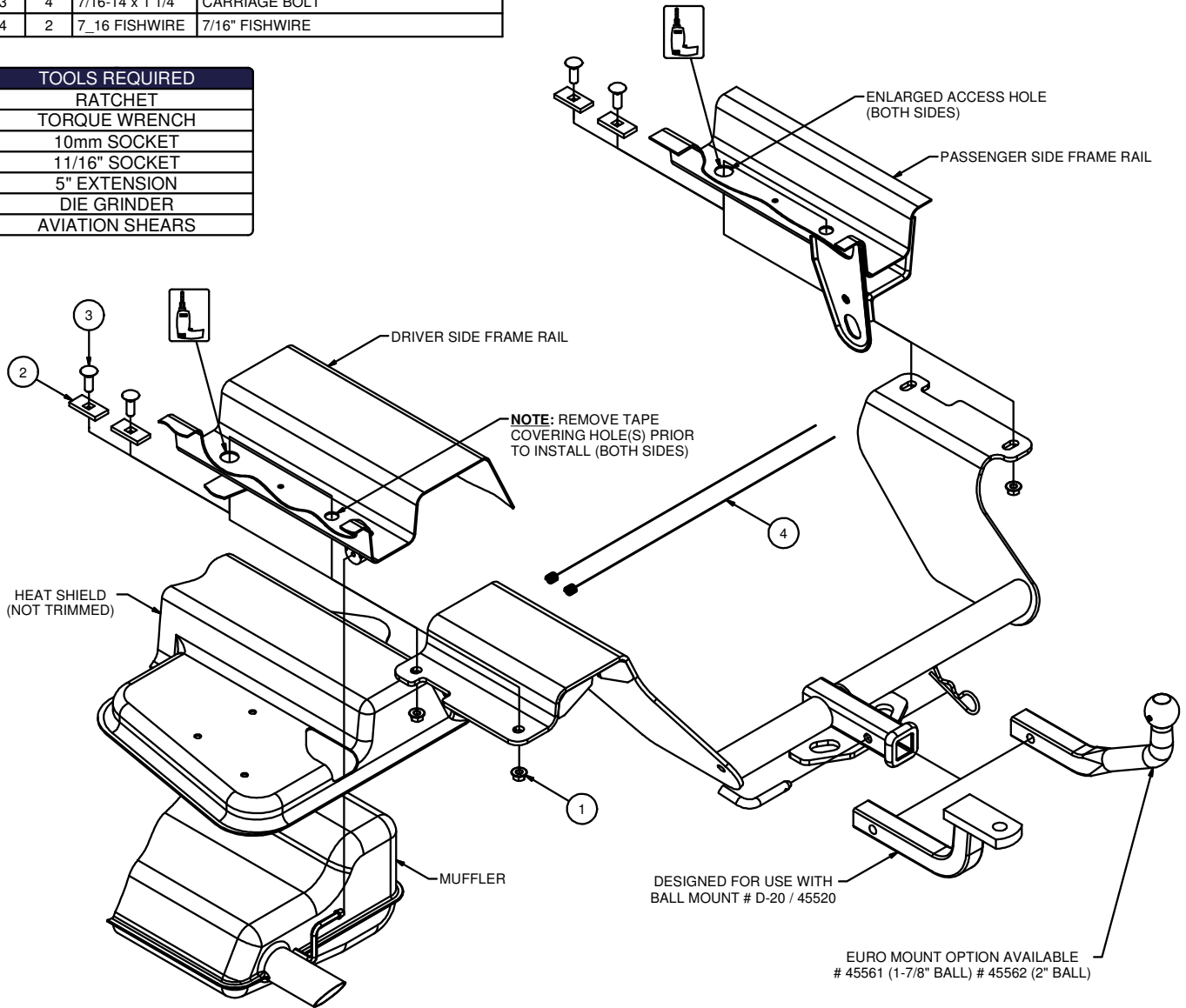

EURO MOUNT OPTION AVAILABLE
45561 (1-7/8" BALL) # 45562 (2" BALL)



HITCH WEIGHT: 37 LBS.
 INSTALL TIME
 PROFESSIONAL: 45 MINUTES
 NOVICE (DIY): 90 MINUTES
 INSTALL NOTES:
 - ENLARGE ACCESS HOLES
 - TRIM HEAT SHIELD
 - LOWER EXHAUST

PERIODICALLY CHECK THIS RECEIVER HITCH TO ENSURE THAT ALL FASTENERS ARE TIGHT AND THAT ALL STRUCTURAL COMPONENTS ARE SOUND.

Curt Manufacturing LLC, warrants this product to be free of defects in material and/or workmanship at the time of retail purchase by the original purchaser. If the product is found to be defective, Curt Manufacturing LLC, may repair or replace the product, at their option, when the product is returned, prepaid, with proof of purchase. Alteration to, misuse of, or improper installation of this product voids the warranty. Curt Manufacturing LLC's liability is limited to repair or replacement of products found to be defective, and specifically excludes liability for incidental or consequential loss or damage.

**RUBBER ISOLATOR
REMOVAL DIAGRAM**

This technique can be used if and Exhaust Hanger Removal Pliers is not available.

Using a 5/8" open end wrench, slide the wrench up to the rubber isolator, cradling the hanger rod as shown. Next place the flat edge of a pry bar between the wrench and the hanger stop or hanger rod. Then simply rotate the pry bar toward the wrench to remove the rubber isolator.

Note: Using a spray lubricant or soapy water on the hanger rod and the rubber isolator helps removal.

**REVERSE PULL FISHWIRE
TECHNIQUE**

ATTACH FISHWIRE TO CARRIAGE BOLT AND SLIDE SPACER ONTO FISHWIRE. PUSH THE BOLT THRU THE HOLE FOLLOWED BY THE SPACER (AS SHOWN). PULL BOLT BACK INTO POSITION, PROTRUDING FROM THE FRAME.

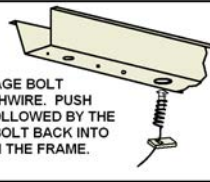
**FISHWIRE TECHNIQUE**

INSERT COILED END OF FISHWIRE TOOL THROUGH HITCH MOUNTING HOLE IN VEHICLE FRAME RAIL AND OUT THE ACCESS HOLE. PASS COILED END OF FISHWIRE THROUGH SPACER AND THREAD BOLT INTO COIL. KINK WIRE TO KEEP SPACER SEPARATE FROM BOLT AS SHOWN. PULL FISHWIRE, SPACER, AND BOLT THROUGH FRAME AND OUT MOUNTING HOLE. USE FISHWIRE TO GUIDE HITCH DURING MOUNTING AND PREVENT LOSS OF BOLT / SPACER INSIDE FRAME RAIL.

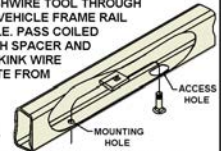

NOTE: SOME VEHICLES MAY FISHWIRE THROUGH END OF FRAME

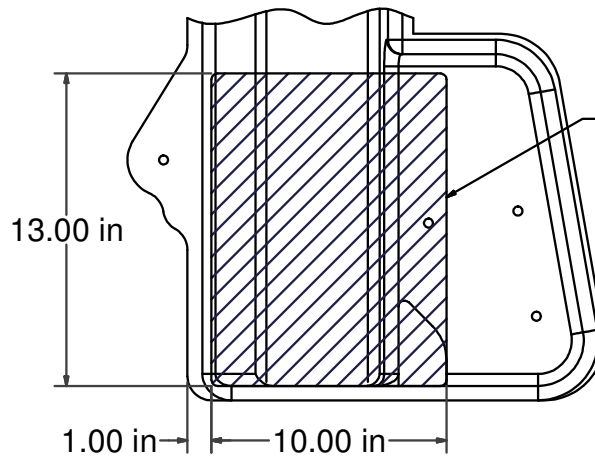

NOTE: DIMENSIONS ARE APPROXIMATE, CONFIRM FIT PRIOR TO TRIMMING

HEAT SHIELD TRIM DIAGRAM

INSTALLATION STEPS

1. Lower exhaust by removing (3) rubber exhaust hangers. (See Rubber Isolator Removal Diagram)
2. Remove the heat shield by removing (6) fasteners. **Note:** If present, remove any tape covering holes in the frame rails.
3. Enlarge the forward most access holes to allow 7/16-14 carriage bolts and SP7 spacers to pass through, both sides.
4. Fishwire 7/16-14 carriage bolts and SP7 spacers through the access holes and out the rear-most holes in the frame rails, both sides. (See Fishwire Technique)
5. Reverse fishwire 7/16-14 carriage bolts and SP7 spacers in the access holes, both sides. (See Reverse Fishwire Technique)
6. Mark heat shield for trimming and confirm the fit. Trim heat shield and reattach using (4) fasteners removed in Step (2). (See Heat Shield Trim Diagram)
7. Raise hitch into position and secure using 7/16-14 flange nuts.
8. Torque all 7/16" hardware to 70 ft-lbs.
9. Raise exhaust and reattach (3) rubber exhaust hangers.

PERIODICALLY CHECK THIS RECEIVER HITCH TO ENSURE THAT ALL FASTENERS ARE TIGHT AND THAT ALL STRUCTURAL COMPONENTS ARE SOUND.