

11117

82-02 CHEVROLET CAMARO / 82-02 PONTIAC FIREBIRD &amp; TRANS AM

GROSS LOAD CAPACITY WHEN USED AS A WEIGHT CARRYING HITCH: 2,000 LBS. TRAILER WEIGHT &amp; 200 LBS. TONGUE WEIGHT.

\*\*\*DO NOT EXCEED VEHICLE MANUFACTURER'S RECOMMENDED TOWING CAPACITY.\*\*\*

WARNING: ALL NON-TRAILER LOADS APPLIED TO THIS PRODUCT MUST BE SUPPORTED BY AUXILIARY STABILIZING STRAPS.

\*\* FAILURE TO PROPERLY SUPPORT NON-TRAILER LOADS WILL VOID PRODUCT WARRANTY\*\*

| Parts List |     |                |  |
|------------|-----|----------------|--|
| ITEM       | QTY | PART NUMBER    | DESCRIPTION                            |
| 1          | 1   | 1/2"           | FISHWIRE TOOL                          |
| 2          | 6   | CM-SP3         | .250 x 1.25 x 2.00" SQUARE HOLE SPACER |
| 3          | 6   | HFN 1213       | HEX FLANGE NUT                         |
| 4          | 6   | 1/2-13 x 1 3/4 | CARRIAGE BOLT                          |

**FISHWIRE TECHNIQUE**

INSERT COILED END OF FISHWIRE TOOL THROUGH HITCH MOUNTING HOLE IN VEHICLE FRAME RAIL AND OUT THE ACCESS HOLE. PASS COILED END OF FISHWIRE THROUGH SPACER AND THREAD BOLT INTO COIL. KINK WIRE TO KEEP SPACER SEPARATE FROM BOLT AS SHOWN. PULL FISHWIRE, SPACER, AND BOLT THROUGH FRAME AND OUT MOUNTING HOLE. USE FISHWIRE TO GUIDE HITCH DURING MOUNTING AND PREVENT LOSS OF BOLT / SPACER INSIDE FRAME RAIL.

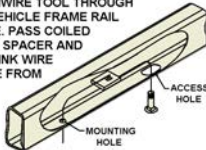

\*NOTE: SOME VEHICLES MAY FISHWIRE THROUGH END OF FRAME\*\*

**RUBBER ISOLATOR REMOVAL DIAGRAM**

This technique can be used if and Exhaust Hanger Removal Pliers is not available.

Using a 5/8" open end wrench, slide the wrench up to the rubber isolator, cradling the hanger rod as shown. Next place the flat edge of a pry bar between the wrench and the hanger stop or hanger rod. Then simply rotate the pry bar toward the wrench to remove the rubber isolator.

Note: Using a spray lubricant or soapy water on the hanger rod and the rubber isolator helps removal.

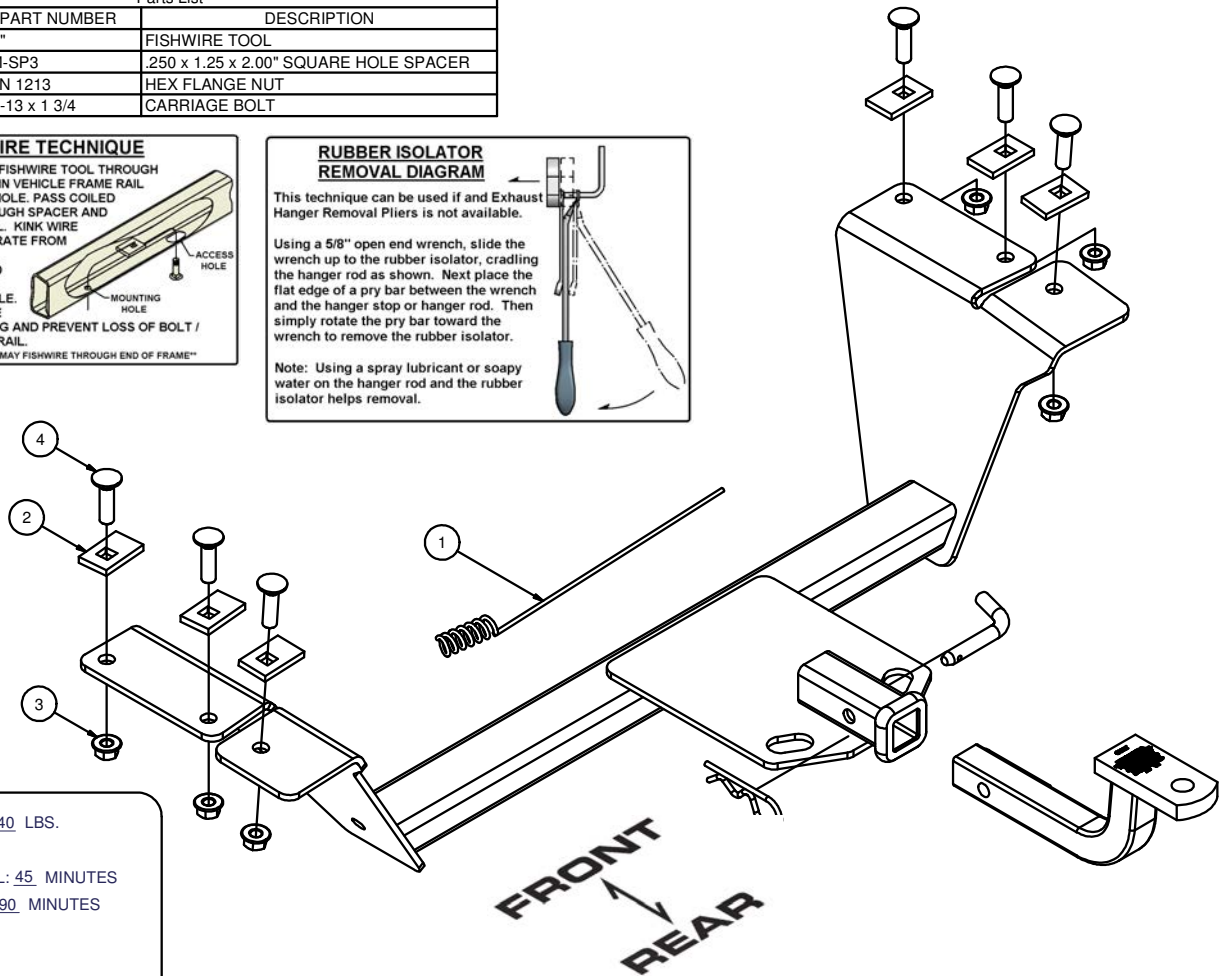
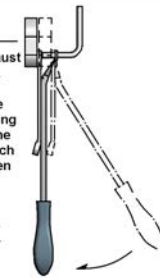

HITCH WEIGHT: 40 LBS.

INSTALL TIME

PROFESSIONAL: 45 MINUTES

NOVICE (DIY): 90 MINUTES

INSTALL NOTES:

**INSTALLATION STEPS**

- 1) Lower vehicle exhaust system by detaching it from exhaust hanger bracket on each side.
- 2) Fishwire (two) 1/4" blocks and 1/2" carriage bolts through the access hole on inboard side of frame rails and through the (two) existing rearward holes.
- 3) Raise hitch into position and loosely install 1/2" nuts on carriage.
- 4) Using the hitch as a template mark the center of forward most hole on the frame rails.
- 5) Lower hitch and drill holes marked in step (4) with 9/16" drill bit.
- 6) Fishwire 1/4" block and 1/2" carriage bolt through access hole and into hole drilled in step 5.
- 7) Raise hitch into position and install fasteners as shown.
- 8) Raise vehicle exhaust system back into position.
- 9) Torque 1/2" fasteners to 110 LB.-FT.

**PERIODICALLY CHECK THIS RECEIVER HITCH TO ENSURE THAT ALL FASTENERS ARE TIGHT AND THAT ALL STRUCTURAL COMPONENTS ARE SOUND.**



The **FIRST** Name  
in Towing Products™

Trailer Hitches