

11092

## KIA RIO 5 / HYUNDAI ACCENT HATCHBACK

GROSS LOAD CAPACITY WHEN USED AS A WEIGHT CARRYING HITCH: 2,000 LBS. TRAILER WEIGHT &amp; 200 LBS. TONGUE WEIGHT.

\*\*\*DO NOT EXCEED VEHICLE MANUFACTURER'S RECOMMENDED TOWING CAPACITY.\*\*\*

WARNING: ALL NON-TRAILER LOADS APPLIED TO THIS PRODUCT MUST BE SUPPORTED BY AUXILIARY STABILIZING STRAPS.

\*\* FAILURE TO PROPERLY SUPPORT NON-TRAILER LOADS WILL VOID PRODUCT WARRANTY\*\*

Parts List			
ITEM	QTY	PART NUMBER	DESCRIPTION
1	2	M12-1.25 x 35mm	HEX BOLT
2	1	1/2-13 x 1 1/2	CARRIAGE BOLT
3	1	1/2-13 x 1 3/4	CARRIAGE BOLT
4	1	CM-SP40	.188 x 1.00 x 3.00" SQUARE HOLE SPACER
5	1	CM-SP34	.188 x 1.50 x 3.00" ROUND HOLE SPACER
6	1	1/2"	FISHWIRE TOOL
7	2	1/2"	CONICAL TOOTHED WASHER
8	2	HFN 1213	HEX FLANGE NUT

## FISHWIRE TECHNIQUE

INSERT COILED END OF FISHWIRE TOOL THROUGH HITCH MOUNTING HOLE IN VEHICLE FRAME RAIL AND OUT THE ACCESS HOLE. PASS COILED END OF FISHWIRE THROUGH SPACER AND THREAD BOLT INTO COIL. KINK WIRE TO KEEP SPACER SEPARATE FROM BOLT AS SHOWN. PULL FISHWIRE, SPACER, AND BOLT THROUGH FRAME AND OUT MOUNTING HOLE. USE FISHWIRE TO GUIDE HITCH DURING MOUNTING AND PREVENT LOSS OF BOLT / SPACER INSIDE FRAME RAIL.

\*\*NOTE: SOME VEHICLES MAY FISHWIRE THROUGH END OF FRAME\*\*

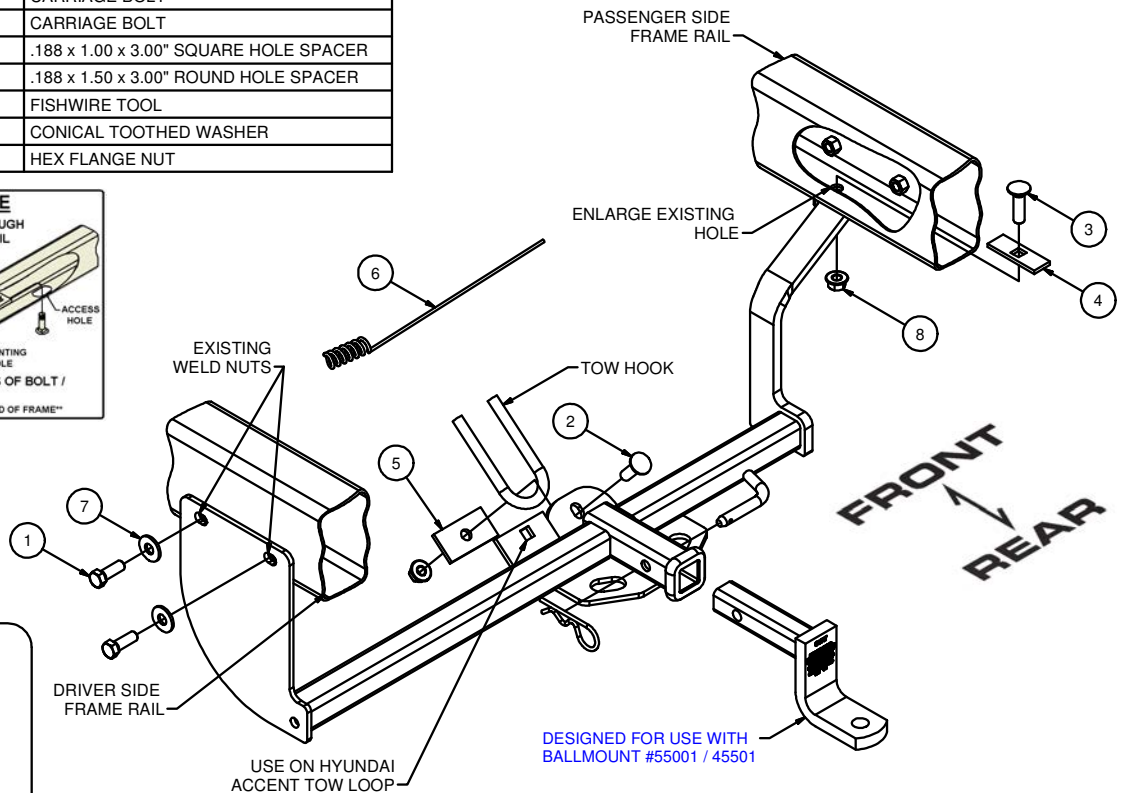

HITCH WEIGHT: 27 LBS.

## INSTALL TIME

PROFESSIONAL: 45 MINUTES

NOVICE (DIY): 90 MINUTES

## INSTALL NOTES:

- HOLE ENLARGEMENT
- FISHWIRE HARDWARE

## INSTALLATION STEPS

1. Lower exhaust for ease of installation.
2. Remove heat shield and cut out corner nearest to hole which gets enlarged, then reattach heat shield.
3. Raise hitch into position, and place 1/2" carriage bolt into safety chain plate above vehicle's tow loop and fasten finger tight with 1/2" flange nut and CM-SP34 spacer as shown.
4. Fasten two M12 bolts with 1/2" conical tooth washers to existing weldnuts in driver side frame rail finger tight as shown.
5. Enlarge hole in passenger side frame rail to fit 1/2" bolt.
6. Fishwire 1/2" carriage bolt with CM-SP40 spacer through passenger side frame rail from edge of bumper to enlarged hole. Fasten finger tight with 1/2" flange nut.
7. Torque all 1/2" hardware to 110 ft-lbs, and all M12 hardware to 86 ft-lbs.
8. Reattach exhaust to hanger locations removed in Step 1.

**PERIODICALLY CHECK THIS RECEIVER HITCH TO ENSURE THAT ALL FASTENERS ARE TIGHT AND THAT ALL STRUCTURAL COMPONENTS ARE SOUND.**



The **FIRST** Name  
in Towing Products™

Trailer Hitches