



# 11067 INSTALLATION INSTRUCTIONS

YEARS: 2011-CURRENT

MAKE: FORD

MODEL: FIESTA (INCLUDING ST)

STYLE: HATCHBACK





**WARNING: NEVER EXCEED YOUR VEHICLE MANUFACTURER'S RECOMMENDED TOWING CAPACITY**

**WEIGHT CARRYING:**  
 TRAILER WEIGHT: 1,500 LBS.  
 TONGUE WEIGHT: 150 LBS.

**INSTALLATION TIME: 30 MIN.**

THE INSTALL TIME LISTED IS FOR PROFESSIONAL INSTALLERS. IF YOU ARE HESITANT TO UNDERTAKE THIS TASK ON YOUR OWN, CONTACT AN AUTHORIZED CURT INSTALLER FOR ADDITIONAL ASSISTANCE.



**INSTALLATION REQUIRES:**

 RATCHET	 TORQUE WRENCH	 9" SOCKET EXTENSION
 10mm 11/16" SOCKET	 AVIATION SHEARS	

**INSTALLATION TIPS:**

- BEFORE YOU BEGIN INSTALLATION, READ ALL INSTRUCTIONS THOROUGHLY.
- TO EASE INSTALLATION, 2 PEOPLE MAY BE REQUIRED.
- USING PROPER TOOLS WILL GREATLY IMPROVE THE QUALITY OF THE INSTALL AND REDUCE THE TIME REQUIRED.

**LEVEL OF DIFFICULTY: MODERATE**

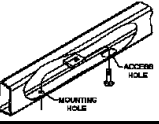
EASY	MODERATE	HARD
	- NO DRILLING REQUIRED	
	- LOWER EXHAUST	
	- TRIM HEAT SHIELD	
	- FISHWIRE HARDWARE	

**VEHICLE PHOTO:**



REPRESENTATIVE PHOTO

**TRAILER HITCH ILLUSTRATION:**

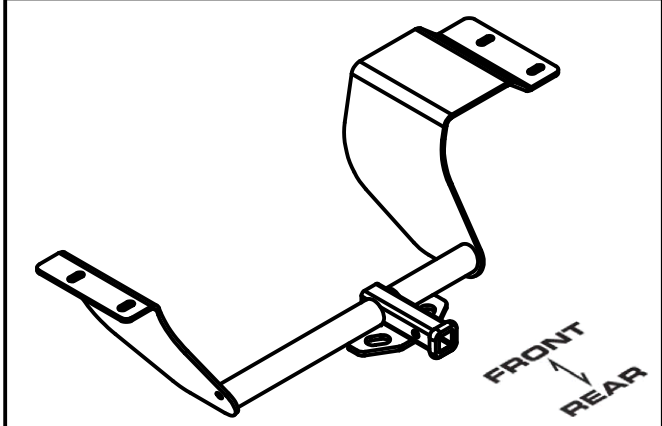

MAKE SURE YOUR HITCH MATCHES

**PERIODICALLY CHECK THIS RECEIVER HITCH TO ENSURE ALL FASTENERS ARE TIGHT AND ALL STRUCTURAL COMPONENTS ARE SOUND**

CURT Manufacturing Inc. warrants this product to be free of defects in material and/or workmanship at the time of retail purchase by the original purchaser. If the product is found to be defective, Curt Manufacturing Inc. may repair or replace the product at their option, when the product is returned, prepaid, with proof of purchase. Alteration to, misuse of, or improper installation of this product voids the warranty. Curt Manufacturing Inc.'s liability is limited to repair or replacement of products found to be defective, and specifically excludes liability for incidental or consequential loss or damage.

## INSTALLATION WALKTHROUGH:

Parts List			
ITEM	QTY	PART NUMBER	DESCRIPTION
1	4	7/16-14	HEX FLANGE NUT
2	2	7_16 FISHWIRE	7/16" FISHWIRE
3	4	7/16-14 x 1 1/4	CARRIAGE BOLT
4	4	CM-SP11	.250 x 1.00 x 2.50" SQUARE HOLE SPACER

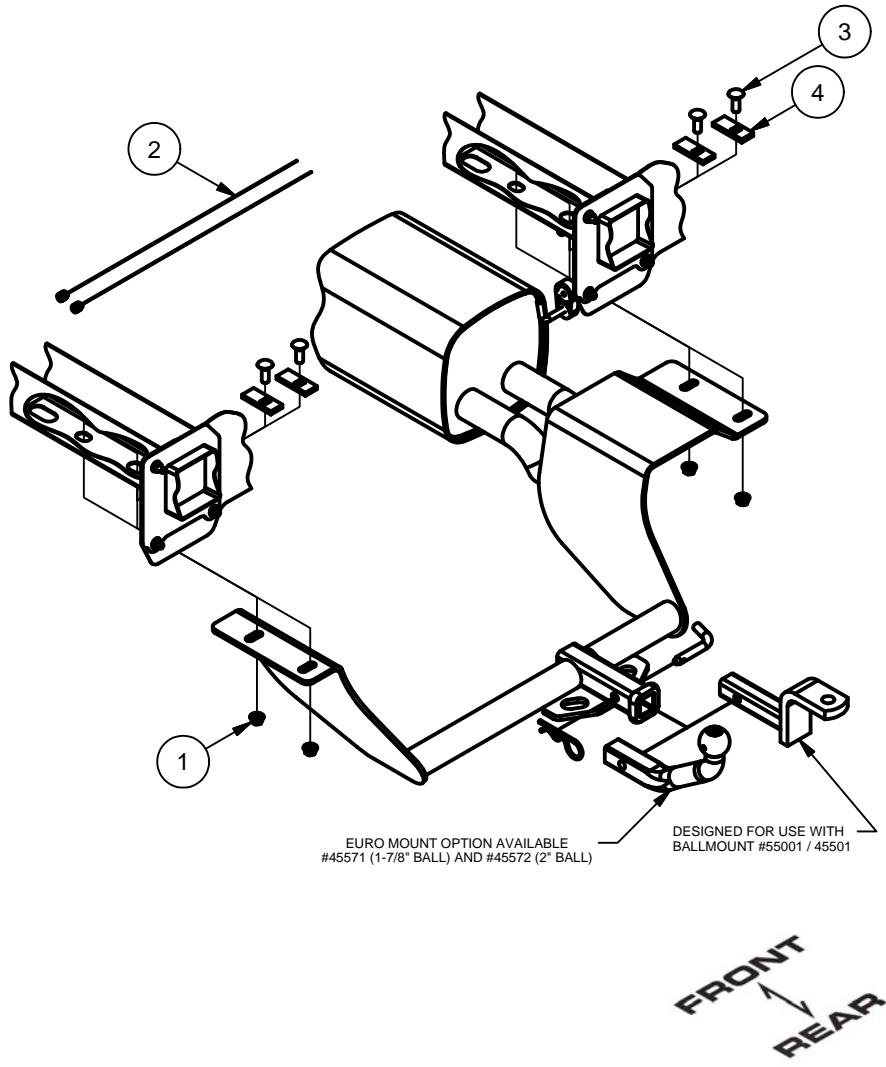

1. Lower exhaust by removing (2) rubber isolators from the hangers attached to the frame.



### RUBBER ISOLATOR REMOVAL DIAGRAM

This technique can be used if an Exhaust Hanger Removal Pliers is not available.

Using a 5/8" open end wrench, slide the wrench up to the rubber isolator, cradling the hanger rod as shown. Next place the flat edge of a pry bar between the wrench and the hanger stop or hanger rod. Then simply rotate the pry bar toward the wrench to remove the rubber isolator.

Note: Using a spray lubricant or soapy water on the hanger rod and the rubber isolator helps removal.



2. Remove (3) fasteners securing the heat shield and remove.



## INSTALLATION WALKTHROUGH:

3. Mark and trim heat shield. Reattach heat shield using fasteners removed in Step (2).

**NOTE:** DIMENSIONS ARE APPROXIMATE, CONFIRM FIT PRIOR TO TRIMMING

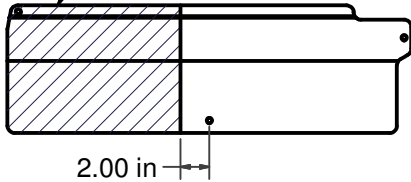

4. Fishwire 7/16-14 x 1 1/4" carriage bolt and SP11 spacer through the rear most hole in the frame and out the next hole towards the front, both sides.

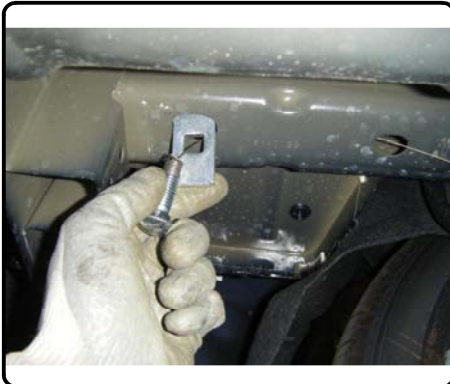

### FISHWIRE TECHNIQUE

INSERT COILED END OF FISHWIRE TOOL THROUGH HITCH MOUNTING HOLE IN VEHICLE FRAME RAIL AND OUT THE ACCESS HOLE. PASS COILED END OF FISHWIRE THROUGH SPACER AND THREAD BOLT INTO COIL. KINK WIRE TO KEEP SPACER SEPERATE FROM BOLT AS SHOWN. PULL FISHWIRE, SPACER, AND BOLT THROUGH FRAME AND OUT MOUNTING HOLE AND OUT MOUNTING HOLE USE FISHWIRE TO GUIDE HITCH DURING MOUNTING AND PREVENT LOSS OF BOLT / SPACER INSIDE FRAME RAIL.

**\*\*NOTE: SOME VEHICLES MAY FISHWIRE THROUGH END OF FRAME\*\***

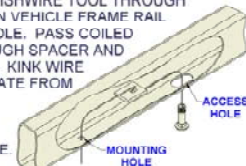

5. Reverse fishwire 7/16-14 x 1 1/4" carriage bolt and SP11 spacer into the rear most hole, both sides.



### REVERSE PULL FISHWIRE TECHNIQUE

ATTACH FISHWIRE TO CARRIAGE BOLT AND SLIDE SPACER ONTO FISHWIRE. PUSH THE BOLT THRU THE HOLE FOLLOWED BY THE SPACER (AS SHOWN). PULL BOLT BACK INTO POSITION, PROTRUDING FROM THE FRAME.

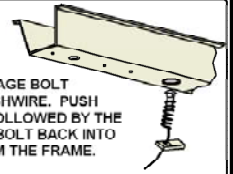

6. Raise hitch over the exhaust and slide it past the exhaust hanger. Secure hitch using 7/16-14 flange nuts. **Note:** When raising hitch into position you may have to push bolts part way back into the frame to get the plates into position. You may use fishwires to guide hitch during mounting to prevent the loss of bolts and spacers inside the frame rails.

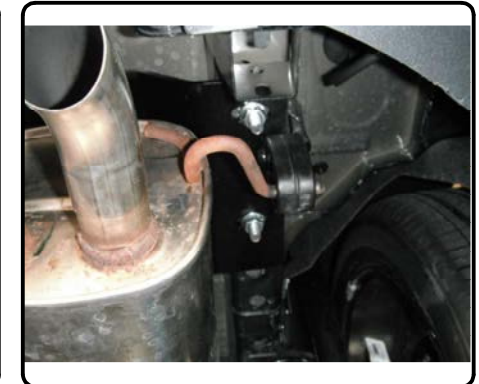
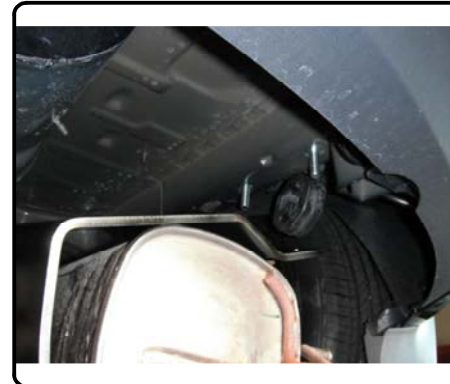

## INSTALLATION WALKTHROUGH:

7. Torque all 7/16" hardware to 10 ft-lbs.  
Raise exhaust back into position.



Hitch installation is complete.



11067

**FORD FIESTA HATCHBACK (INCLUDING ST)**

**GROSS LOAD CAPACITY WHEN USED AS A WEIGHT CARRYING HITCH: 1,500 LBS. TRAILER WEIGHT & 150 LBS. TONGUE WEIGHT.**

\*\*\*DO NOT EXCEED VEHICLE MANUFACTURER'S RECOMMENDED TOWING CAPACITY.\*\*\*

**WARNING: ALL NON-TRAILER LOADS APPLIED TO THIS PRODUCT MUST BE SUPPORTED BY 18050 STABILIZING STRAPS.**

\*\* FAILURE TO PROPERLY SUPPORT NON-TRAILER LOADS WILL VOID PRODUCT WARRANTY\*\*

Parts List				
ITEM	QTY	PART NUMBER	DESCRIPTION	
1	4	7/16-14	HEX FLANGE NUT	
2	2	7_16 FISHWIRE	7/16" FISHWIRE	
3	4	7/16-14 x 1 1/4	CARRIAGE BOLT	
4	4	CM-SP11	.250 x 1.00 x 2.50" SQUARE HOLE SPACER	

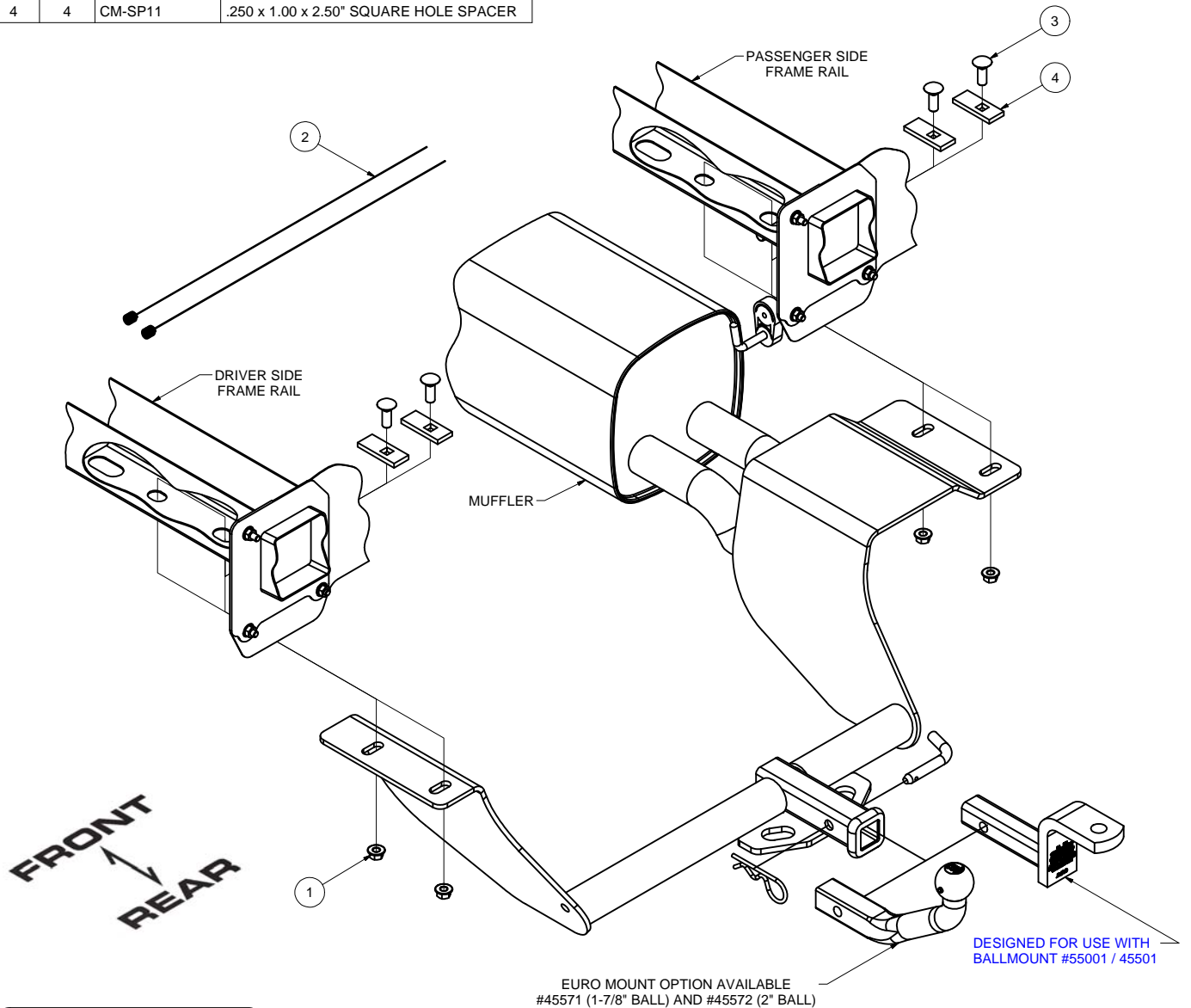

**HITCH WEIGHT: 34 LBS.**  
**INSTALL TIME**  
 PROFESSIONAL: 30 MINUTES  
 NOVICE (DIY): 60 MINUTES  
**INSTALL NOTES:**  
 - NO DRILLING REQUIRED  
 - LOWER EXHAUST  
 - TRIM HEAT SHIELD  
 - FISHWIRE HARDWARE

**PERIODICALLY CHECK THIS RECEIVER HITCH TO ENSURE THAT ALL FASTENERS ARE TIGHT AND THAT ALL STRUCTURAL COMPONENTS ARE SOUND.**

Curt Manufacturing Inc., warrants this product to be free of defects in material and/or workmanship at the time of retail purchase by the original purchaser. If the product is found to be defective, Curt Manufacturing Inc., may repair or replace the product, at their option, when the product is returned, prepaid, with proof of purchase. Alteration to, misuse of, or improper installation of this product voids the warranty. Curt Manufacturing Inc.'s liability is limited to repair or replacement of products found to be defective, and specifically excludes liability for incidental or consequential loss or damage.

**RUBBER ISOLATOR  
REMOVAL DIAGRAM**

This technique can be used if and Exhaust Hanger Removal Pliers is not available.

Using a 5/8" open end wrench, slide the wrench up to the rubber isolator, cradling the hanger rod as shown. Next place the flat edge of a pry bar between the wrench and the hanger stop or hanger rod. Then simply rotate the pry bar toward the wrench to remove the rubber isolator.

Note: Using a spray lubricant or soapy water on the hanger rod and the rubber isolator helps removal.

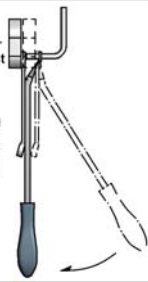
**FISHWIRE TECHNIQUE**

INSERT COILED END OF FISHWIRE TOOL THROUGH HITCH MOUNTING HOLE IN VEHICLE FRAME RAIL AND OUT THE ACCESS HOLE. PASS COILED END OF FISHWIRE THROUGH SPACER AND THREAD BOLT INTO COIL. KINK WIRE TO KEEP SPACER SEPERATE FROM BOLT AS SHOWN. PULL FISHWIRE, SPACER, AND BOLT THROUGH FRAME AND OUT MOUNTING HOLE. USE FISHWIRE TO GUIDE HITCH DURING MOUNTING AND PREVENT LOSS OF BOLT / SPACER INSIDE FRAME RAIL.

\*\*NOTE: SOME VEHICLES MAY FISHWIRE THROUGH END OF FRAME\*\*

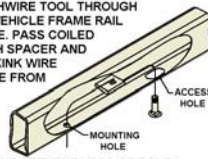
**REVERSE PULL FISHWIRE  
TECHNIQUE**

ATTACH FISHWIRE TO CARRIAGE BOLT AND SLIDE SPACER ONTO FISHWIRE. PUSH THE BOLT THRU THE HOLE FOLLOWED BY THE SPACER (AS SHOWN). PULL BOLT BACK INTO POSITION, PROTRUDING FROM THE FRAME.

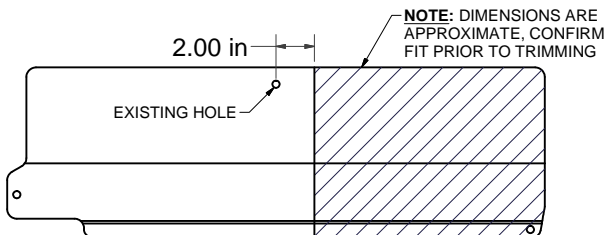
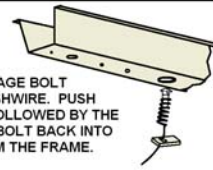

HEAT SHIELD TRIM DIAGRAM

**TOOLS REQUIRED**

RATCHET
TORQUE WRENCH
9" EXTENSION
10mm SOCKET
11/16" SOCKET
AVIATION SHEARS

**INSTALLATION STEPS**

1. Lower exhaust by removing (2) rubber isolators from the hangers attached to the frame. (See Rubber Isolator Removal Diagram)
2. Remove (3) fasteners securing the heat shield and remove.
3. Mark and trim heat shield. Reattach heat shield using fasteners removed in Step (2). (See Heat Shield Trim Diagram)
4. Fishwire 7/16-14 x 1 1/4" carriage bolt and SP11 spacer through the rear most hole in the frame and out the next hole towards the front, both sides. (See Fishwire Technique)
5. Reverse fishwire 7/16-14 x 1 1/4" carriage bolt and SP11 spacer into the rear most hole, both sides. (See Reverse Fishwire Technique)
6. Raise hitch over the exhaust and slide it past the exhaust hanger. Secure hitch using 7/16-14 flange nuts.  
**Note:** When raising hitch into position you may have to push bolts part way back into the frame to get the plates into position. You may use fishwires to guide hitch during mounting to prevent the loss of bolts and spacers inside the frame rail.
7. Torque all 7/16" hardware to 70 ft-lbs.
8. Raise exhaust back into position.

PERIODICALLY CHECK THIS RECEIVER HITCH TO ENSURE THAT ALL FASTENERS ARE TIGHT AND THAT ALL STRUCTURAL COMPONENTS ARE SOUND.