

11066

1998 - 2010 VOLKSWAGEN BEETLE INCLUDING CONVERTIBLE (Except Turbo)
1999 1/4 - 2006 VOLKSWAGEN GOLF HATCHBACK (Except VR6, R32 & 4-MOTION)
1999 1/4 - 2005 VOLKSWAGEN GTI COUPE
2007 - 2009 VOLKSWAGEN CITY GOLF (CANADIAN ONLY)

GROSS LOAD CAPACITY WHEN USED AS A WEIGHT CARRYING HITCH: 2,000 LBS. TRAILER WEIGHT & 200 LBS. TONGUE WEIGHT.

*****DO NOT EXCEED VEHICLE MANUFACTURER'S RECOMMENDED TOWING CAPACITY.*****

WARNING: ALL NON-TRAILER LOADS APPLIED TO THIS PRODUCT MUST BE SUPPORTED BY AUXILIARY STABILIZING STRAPS.

**** FAILURE TO PROPERLY SUPPORT NON-TRAILER LOADS WILL VOID PRODUCT WARRANTY****

Parts List			
ITEM	QTY	PART NUMBER	DESCRIPTION
1	1	3/8 - 16 x 1 3/4	HEX BOLT
2	6	3/8"	FENDER WASHER
3	1	CM-SP52	.500 x 1.25 x 2.50" ROUND HOLE SPACER
4	5	3/8 - 16 x 1 1/4	HEX BOLT
5	6	HFN3816	HEX FLANGE NUT
6	1	1/2-13	HANDLE NUT
7	1	FW12	FW, 12, ZP
8	1	1/2"	CONICAL TOOTHED WASHER
9	1	1/2-13 x 1 1/4	HEX BOLT

FRONT
↑
REAR

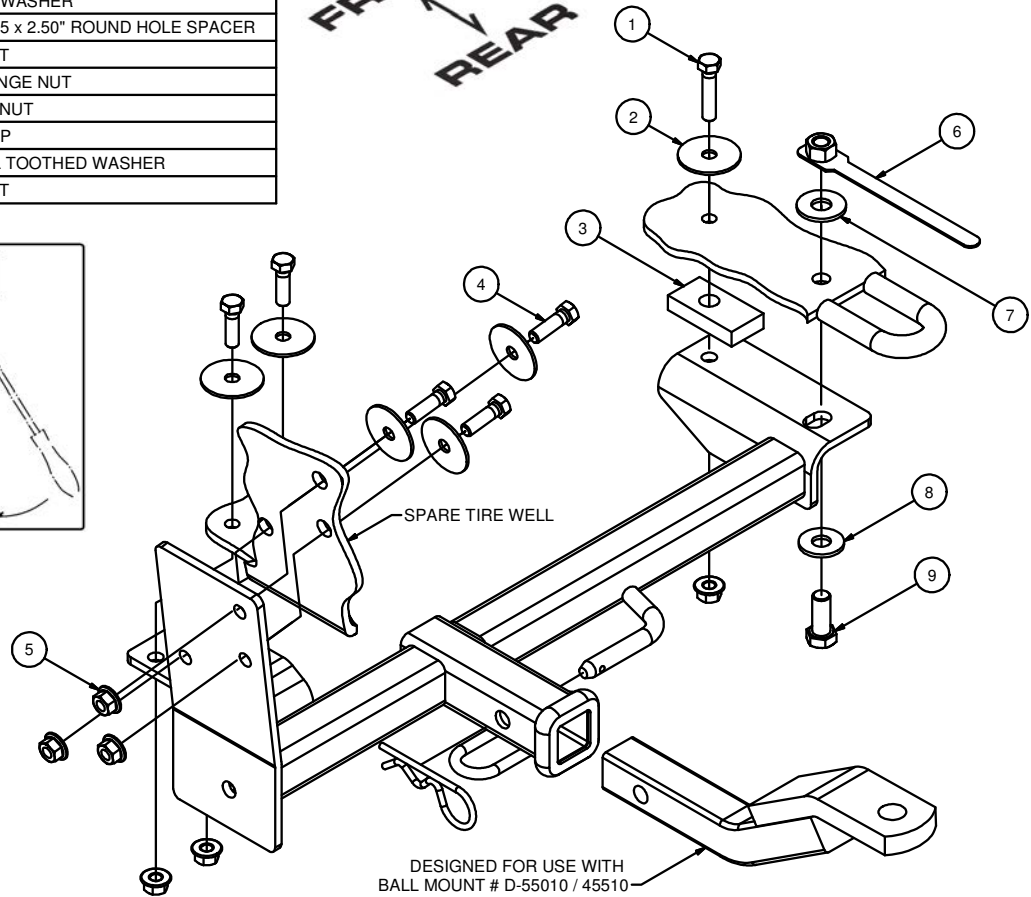
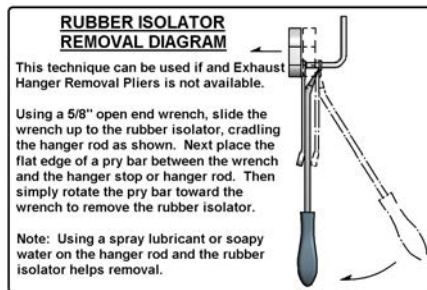

HITCH WEIGHT: 18 LBS.

INSTALL TIME

PROFESSIONAL: 20 MINUTES

NOVICE (DIY): 40 MINUTES

INSTALL NOTES:

- TEMPORARILY REMOVE SPARE
- LOWER EXHAUST
- DRILLING REQUIRED

INSTALLATION STEPS

1. Temporarily remove spare tire and lower exhaust to ease installation.
2. Lift hitch into position, aligning the hole on the passenger side plate with the second hole forward from the tie down loop opening. Using the hitch as a template, drill a 3/8" hole up into trunk. Loosely install long 3/8" bolt, fender washer, spacer, and hex flange nut as shown.
3. Use slot in passenger side plate as a template and drill a 1/2" hole into trunk pan. Loosely install 1/2" bolt, conical toothed washer, flat washer and handle nut as shown. Cut handle off handle nut if needed after installation.
4. With hitch in position and square on vehicle, use driver side plates as templates and drill remaining (5) 3/8" holes through trunk pan. Install short 3/8" bolts, fender washers and hex flange nuts as shown.
5. Torque all 1/2" hardware to 110 lb.-ft. and all 3/8" hardware to 45 lb.-ft. Apply silicone sealer to holes in trunk pan.

PERIODICALLY CHECK THIS RECEIVER HITCH TO ENSURE THAT ALL FASTENERS ARE TIGHT AND THAT ALL STRUCTURAL COMPONENTS ARE SOUND.



The **FIRST** Name
in Towing Products™

Trailer Hitches