

INSTALLATION INSTRUCTIONS

WARNING: NEVER EXCEED YOUR VEHICLE MANUFACTURER S RECOMMENDED TOWING

CAPACITY FORD OEM COMPATIBLE 5TH WHEEL ROLLER



UNPACKING THE ROLLER

Inspect all parts for damage and verify that all items listed are present.

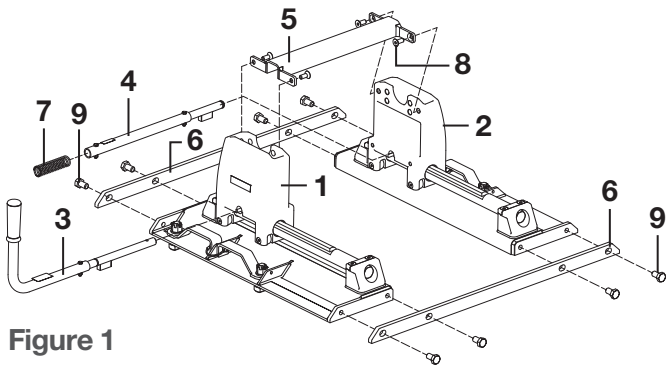

Figure 1

PARTS LIST

| Item# | Qty | Description |
|-------|-----|--|
| 1 | 1 | Roller assembly, driver side (DS) |
| 2 | 1 | Roller assembly, passenger side (PS) |
| 3 | 1 | Handle assembly |
| 4 | 1 | Handle center section |
| 5 | 1 | Cross member weldment |
| 6 | 2 | End connector |
| 7 | 1 | Compression spring |
| 8 | 4 | Flat head socket cap screw, M10 x 25mm |
| 9 | 8 | Hex head cap screw, M14 x 25mm |

WARNINGS

Read and understand instructions before using this product. Fully instruct and demonstrate the operation of this 5th wheel hitch to the end user. Include the importance of observing all warnings contained herein, including warning labels on 5th wheel hitch mid section. Provide this manual in its entirety to the end-user.

To avoid serious injury, do not expose hands, body parts or clothing between the truck and trailer or the truck's bed sides and trailer. Extreme care should be observed to avoid serious injury to self, property and observers.

Never position yourself or others under the trailer's kingpin area during coupling and uncoupling. Serious injury or death may result if the warning above is not observed. This product complies with V-5 regulations and safety requirements for connecting devices and towing systems of the State of Wisconsin.

ASSEMBLY INSTRUCTIONS

Step 1

Grease the ends of the handle assembly (#3) and the handle center section (#4) as shown in figure 2.

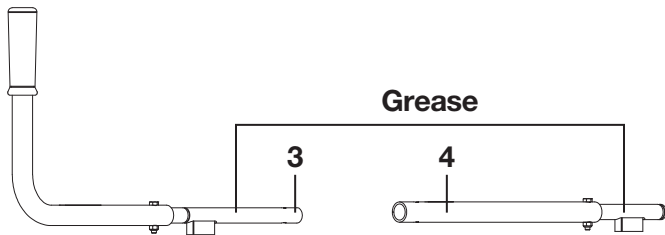

Figure 2

Step 2

Slide the handle assembly (#3) into the driver side roller assembly (#1) and slide the handle center section (#4) into the passenger side roller assembly (#2) as shown in figure 3.

Step 3

Slide the compression spring (#7) over the handle assembly (#3) as shown in figure 3.

Step 4

Slide the handle assembly (#3) with compression spring (#7) into the handle center section (#4) until the holes line up. Secure with 6mm bolt and 6mm nylock nut. Tighten until nylock nut is fully engaged. Shown in figure 3.

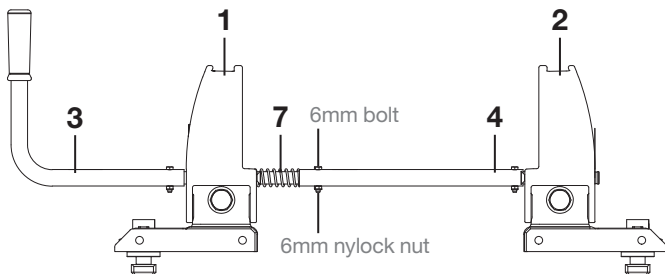

Figure 3

Step 5

Slide cross member weldment (#5) between the driver side roller assembly (#1), passenger side roller assembly (#2) and over the handle center section (#4) as shown in figure 4. Secure with M10 flat head screws (#8). Do not fully tighten at this time.

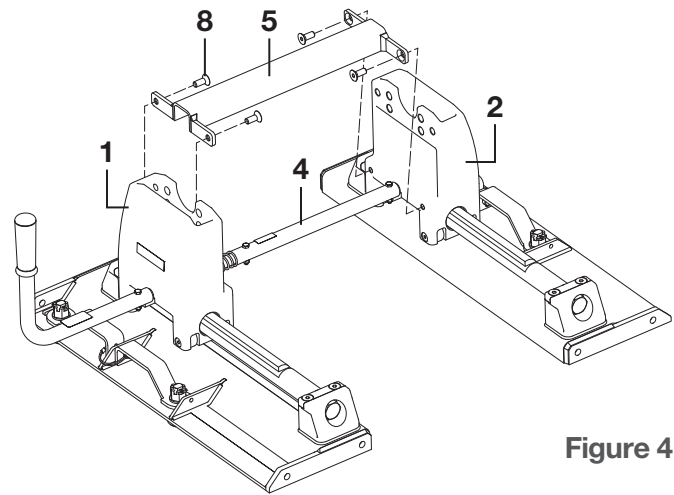

Figure 4

Step 6

Fasten the end connectors (#6) to the driver side roller assembly (#1) and passenger roller assembly (#2) using M14 hex head screws (#9) as shown in figure 5. Do not fully tighten at this time.

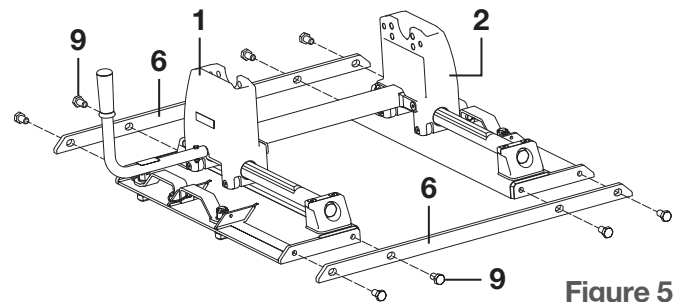

Figure 5

Step 7

Remove the two lynch pins securing the locking handles to the roller assemblies. Swing all four handles completely open and lower the assembly into position in the bed of the truck as shown in figure 6.

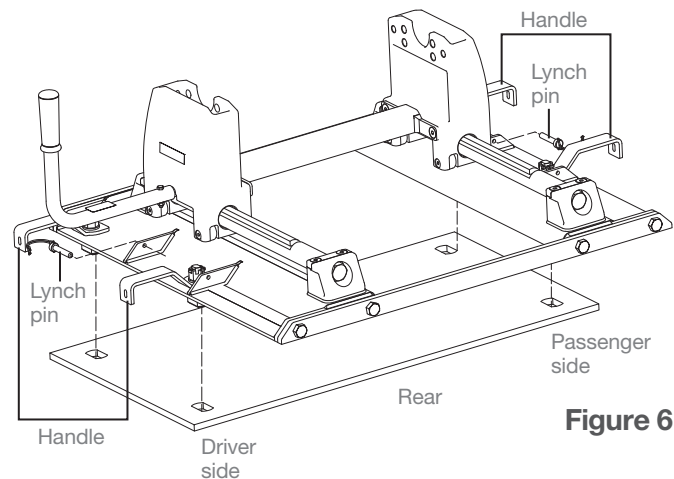

Figure 6

5TH WHEEL HEAD INSTALLATION

Install the 16515, 16520, 16530 or the 16545 5th wheel head by sliding it into the roller assembly as shown in figure 7. Select desired height using the adjustment holes in the mid section of the 5th wheel head. From the inside, secure the head unit to the roller assembly with the four 14mm bolts supplied. Torque to 100 foot-lbs.

With head unit installed, torque four M10 flat head screws attaching slide cross member weldment to 35 foot-lbs. Also torque eight M14 hex head screws attaching center connectors to the driver side roller assembly and passenger side roller assembly to 100 foot-lbs. See figure 7.

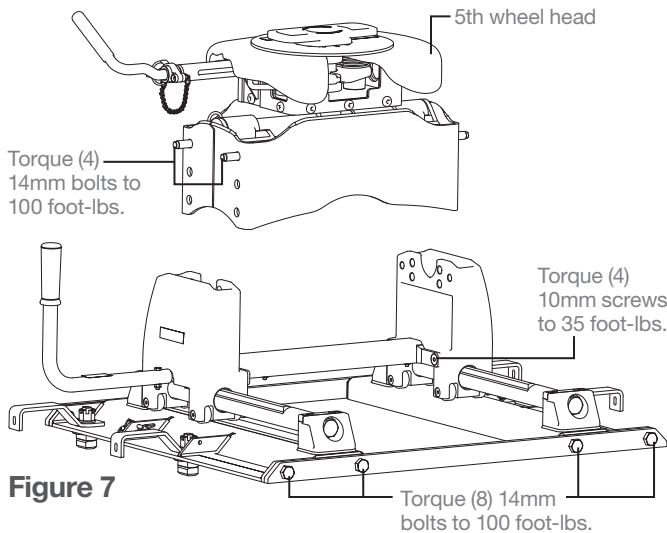

Figure 7

With all fasteners properly torqued, rotate the handles back to the closed position. Secure the handles by re-inserting both lynch pins. See figure 8. Do not force the handles closed. If the handles will not close with moderate pressure see 'T-Bolt Adjustment'.

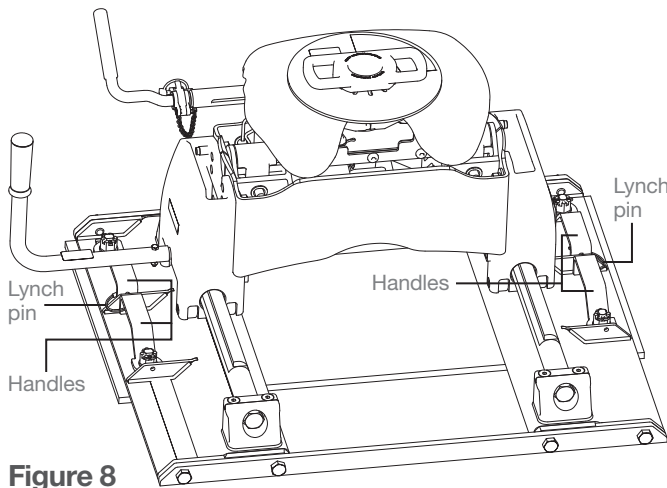

Figure 8

T-BOLT ADJUSTMENT

Step 1

The locking T-bolts have been pre-installed to ease installation. Due to possible variation in the trucks mounting locations, some adjustments may be required. If one or more of the locking handles will not close, begin adjustment by removing the cotter pin securing the castle nut above the handle. See figure 9.

Step 2

Loosen the castle nut a quarter-turn while pressing down on the T-bolt.

Step 3

Re-attempt to close the locking handle. If the handle closes, re-secure the castle nut with the removed cotter pin. If the handle does not close, repeat step 2.

Step 4

Confirm all four locking bolts are engaged in the truck bed mounts and the castle nuts are secured with the cotter pins. Finally, double check to ensure all four handles are securely locked with the lynch pins. The 16020 is now installed and ready for use.

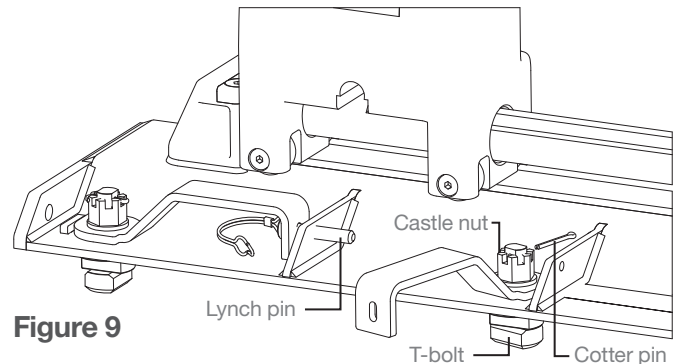

Figure 9

REMOVAL OF THE 5TH WHEEL HEAD & ROLLER

For removal of the 5th wheel head from the 16020 roller, reverse the steps found under the '5th Wheel Head Installation'. For removal of the 16020 roller, reverse steps 3 through 7 found under the 'Assembly Instructions'. Also see figures 3 and 4.

OPERATING INSTRUCTIONS

To maneuver

Align trailer and tow vehicle in a straight line, on a level surface.

Pull handle out and rotate counter-clockwise to place lock bar in the ready-to-lock position.

Set trailer brakes and slowly drive the tow vehicle forward until R24 roller stops. Locking bars will automatically engage in the rear locking groove. **NOTE:** Visually check that lock bar handle is vertical, both lock bars are fully engaged and that the green indicator is visible.

Maneuver position

Roller and hitch will move 12" rearward

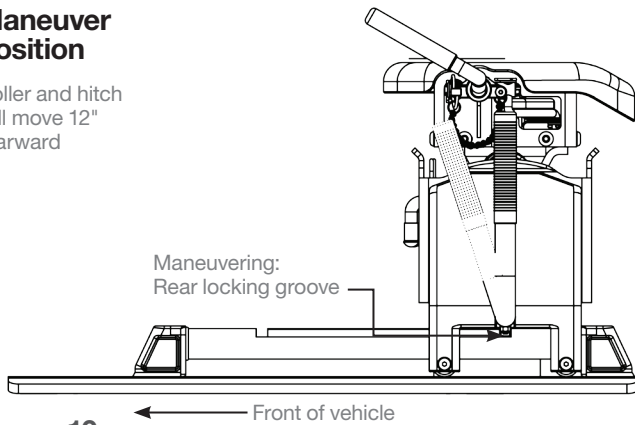

Figure 10

To tow

Align trailer and tow vehicle in a straight line, on a level surface.

Pull handle out and rotate clockwise to place lock bar in the ready-to-lock position.

Set trailer brakes and slowly back up the tow vehicle until R24 roller stops. Lock bars will automatically engage in the forward locking groove. **NOTE:** Visually check that lock bar handle is vertical, both lock bars are fully engaged and that the green indicator is visible. Set trailer brakes and move the tow vehicle forward slightly to be sure both lock bars are fully engaged. You are now ready to tow.

Towing position

Roller and hitch will move 12" forward

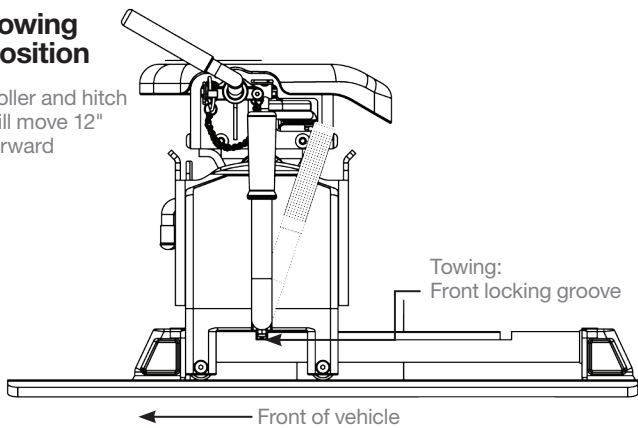

Figure 11