

INSTALLATION MANUAL

70116

Level of Difficulty

Moderate

Installed Attachment Tabs

Height	13-1/2"
Width	18"

Parts List

Item	Qty	Description
1	1	Tow bar base plate
2	2	Tow bar mounting tab
3	2	Safety cable, 3,500 lbs.
4	8	Carriage bolt, 3/8"-16 x 1-1/2", grade 8
5	8	Square hole spacer, 1/4" x 1" x 2"
6	8	Flange nut, 3/8"-16, grade 8
7	2	Quick link, 1/4"
8	2	Socket plug

Tools Required

Torque wrench	Drill
Socket, 9/16"	Drill bit, 1/4"
Socket, 10mm	Drill bit, 13/32"
Socket, 13mm	T20 Torx
Reciprocating saw	Tape measure
Large vise grip	Phillips screwdriver
Utility knife	Flat head screwdriver
Fishwire, 3/8" (includes eight)	--

⚠ WARNING

Never exceed the vehicle manufacturer's recommended gross vehicle weight rating (GVWR).

Product Photo



Not pictured: Safety cables, quick links and socket plugs

⚠ CAUTION

Take care when cutting any plastic or metal as injury may occur if done improperly.

NOTICE

Before you begin installation, read all instructions thoroughly.

Proper tools will improve the quality of installation and reduce the time required.

This installation requires front fascia panels, supports and a portion of the underbody panel to be temporarily removed and reinstalled. Some drilling and trimming are required.

To help prevent damage to the product or vehicle, refer to the specified torque specifications when securing hardware during the installation process.

If equipped, we recommend removing the base plate attachment tabs when not in use.

ASSEMBLY

Parts List

Item	Qty	Description
1	1	Tow bar base plate
2	2	Tow bar mounting tab
3	2	Safety cable, 3,500 lbs.
4	8	Carriage bolt, 3/8"-16 x 1-1/2", grade 8
5	8	Square hole spacer, 1/4" x 1" x 2"
6	8	Flange nut, 3/8"-16, grade 8
7	2	Quick link, 1/4"
8	2	Socket plug

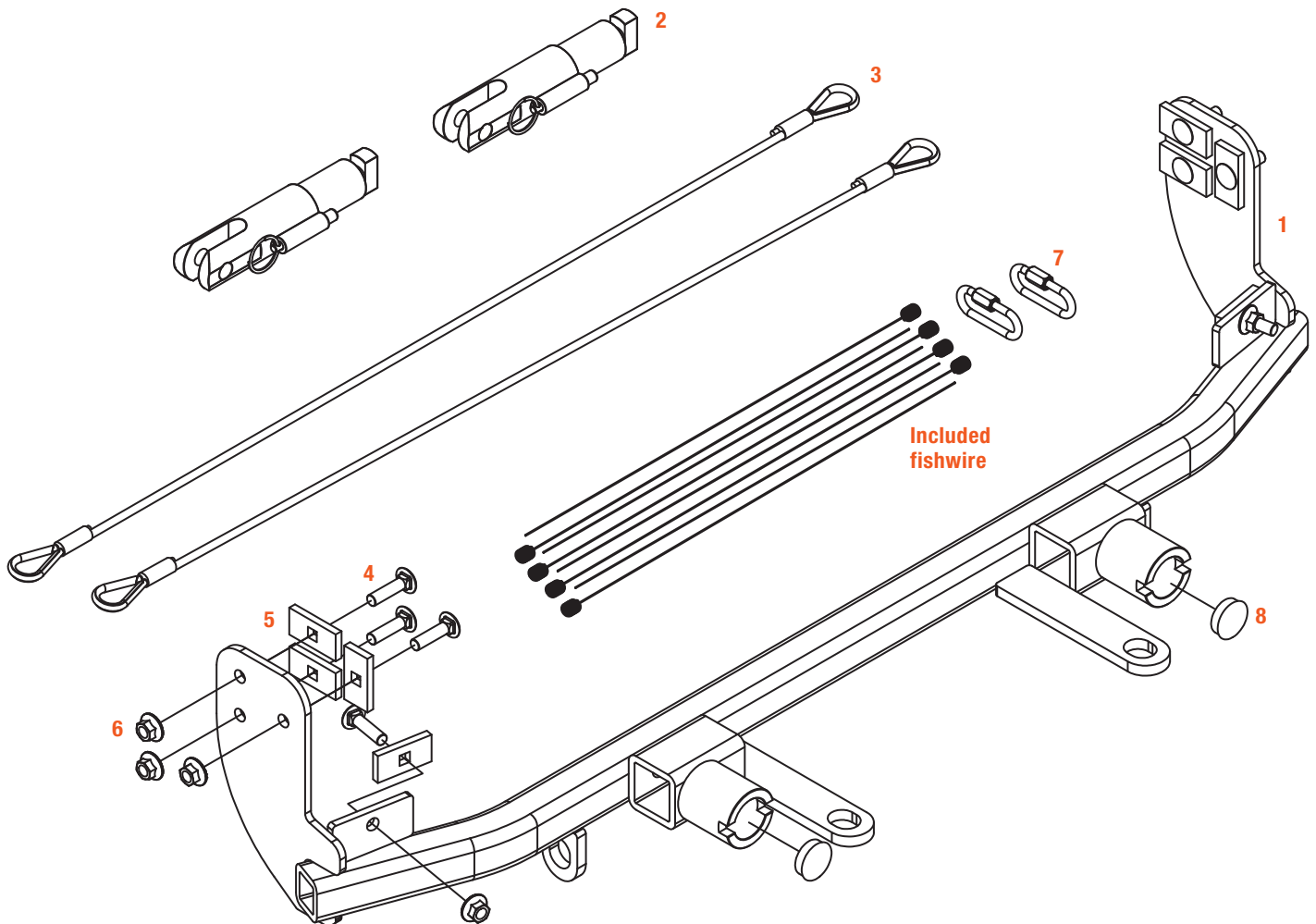

BUMPER REMOVAL

Step 1

Open the hood and remove the six push pins in the top fascia cover, three on either side of the vehicle. Then, use a 10mm socket to remove the four bolts from the cover, two on either side.

Note: For some models, there will be six bolts in the cover, instead of four.

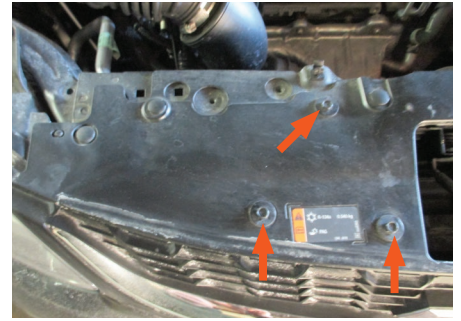
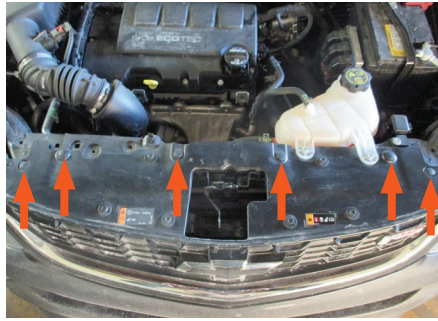

Step 2

Use a T20 Torx bit to remove the four screws along the inside edge of the wheel well liner.

Repeat on the other side of the vehicle.

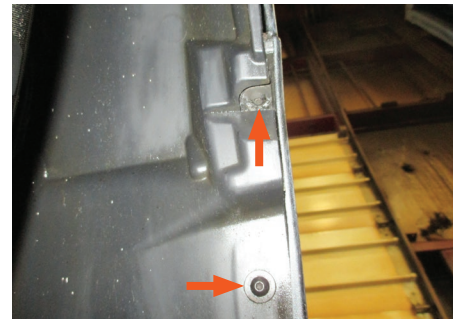

Step 3

Use a T20 Torx bit to remove the seven bolts holding the underbody fascia, three on either side and one in the center.



Step 4

Remove the center push pin from the underbody panel. Then, use a 13mm socket to remove the two bolts on either side.

Some models may have a screw in the bumper fascia, directly below the license plate. If present, use a T20 Torx bit to remove the screw. Then, remove the front portion of the underbody panel and set it aside.

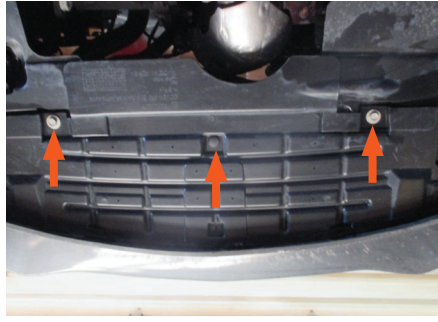

Step 5

Use a Phillips head screwdriver to remove the two screws in the bumper fascia brackets, one on either side.

Note: For 2019 models, there will be 7mm bolts instead of Phillips head screws.

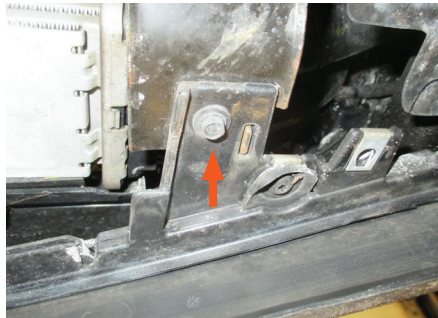

Step 6

Remove the bumper fascia by pulling up and out at the edges, near the wheel wells. Make sure to disconnect any electrical harnesses.

Then, remove the bumper fascia entirely and set it aside.

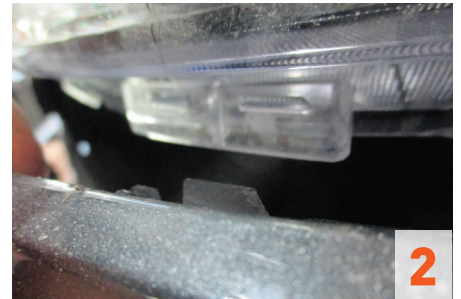

Step 7

Use a 13mm socket to remove the three bolts in the lower fascia support bracket.

Repeat this on the other side.

Remove the support and set it aside.

For non-turbo models: Trim off the flanges extending forward of the vehicle as needed to clear the base plate. Mark the area with a paint pen and use a utility knife to trim the marked area. Repeat on the other side of the vehicle.

For RS models: Remove the plastic shroud by pulling out the two push pins on either side. Return the shroud and fasteners to vehicle's owner. It will not be reinstalled.

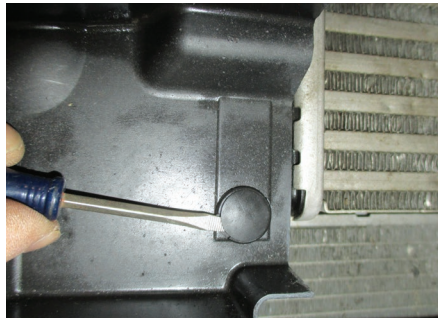
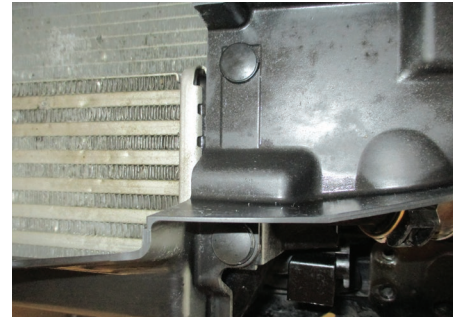
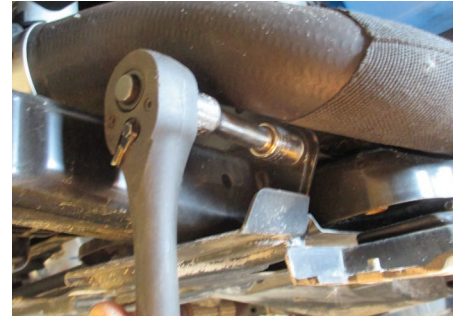
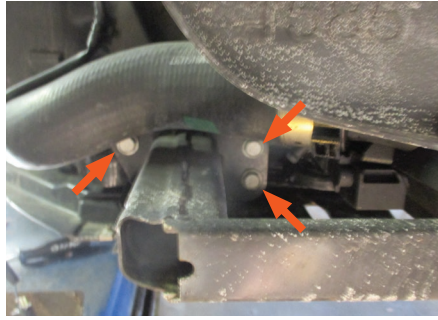

Step 8

As shown, mark a notch in the bumper about 2" from the edge. Then, use a metal-cutting tool (reciprocating saw or cutoff wheel) to cut off the marked area.

Repeat on the other side.



TOW BAR BASE PLATE INSTALLATION

Step 9

Position the tow bar base plate (#1) on the frame making sure the support tabs are just below the bumper. Level the base plate, and clamp it into place.

Note: Take care not to damage hoses or wiring when rotating the base plate into position.

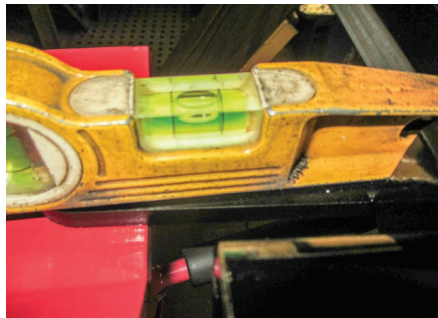
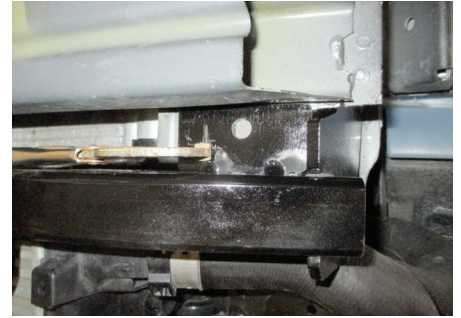

Step 10

Using the bottom hole in the side plate as a guide, drill a 13/32" hole in the vehicle frame.

Then, fishwire a 3/8" carriage bolt (#4) and square hole spacer (#5) into the frame and into the drilled hole and secure it with a 3/8" flange nut (#6).

Repeat on the other side of the vehicle.

Then, make sure the base plate is level, and torque the hardware to 37 lb-ft.

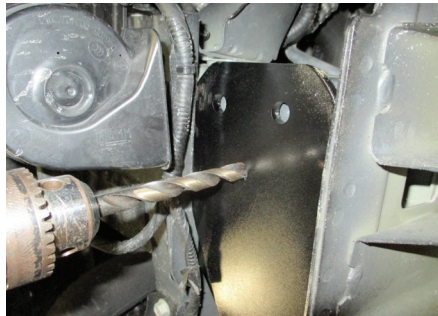

Step 11

Drill the top two holes in the side plate with a 13/32" bit. Also, drill the front-facing hole.

Then, fishwire and install 3/8" carriage bolts (#4) and square hole spacers (#5) in each hole and secure with 3/8" flange nuts (#6).

Repeat on the other side of the vehicle, and torque all hardware to 37 lb-ft.

Note: The car horn bracket may need to be moved temporarily to allow space for drilling.

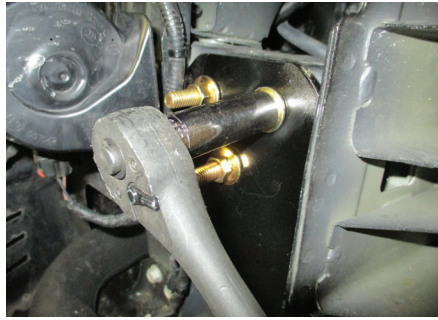
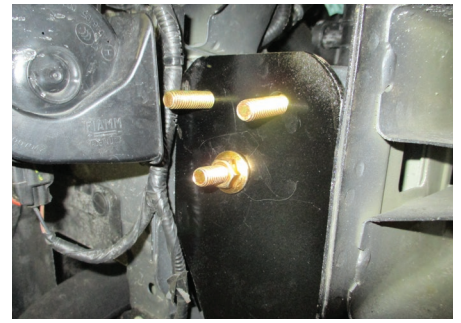
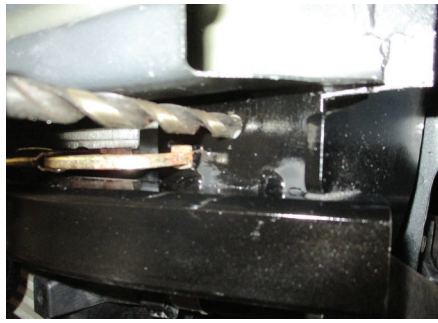

Step 12

Install the permanent safety cables (#4) and quick links (#11), looping them around the vehicle frame and linking them to the tow bar base plate (#1). There must be one cable on each side of the vehicle.

Make sure the cables do not pinch or interfere with any hoses, wiring or other components.

See 'Installing the Permanent Base Plate Safety Cables' for additional information.

For RS models: Use a Phillips head screwdriver to remove the lower fog light housing bracket. Then, mark off the areas as shown, and use a utility knife to trim the marked areas. Repeat on the other side of the vehicle.

For vehicles with a passenger-side temperature sensor: Remove the sensor from the back side of the bumper fascia, and use a zip tie to reattach it to the base plate.



Step 13

Hold up the front fascia in its original position and mark where it will need to be trimmed to make space for the safety cable loops and attachment tabs. Trim off the marked area.

Then, reinstall the panel, making sure to reconnect the electrical harnesses. Reinstall any additional panels or components that were previously removed during the install.

When ready to tow, install the tow bar mounting tabs (#2). When not towing, insert the socket plugs (#8) into the ends of the tow bar base plate (#1).

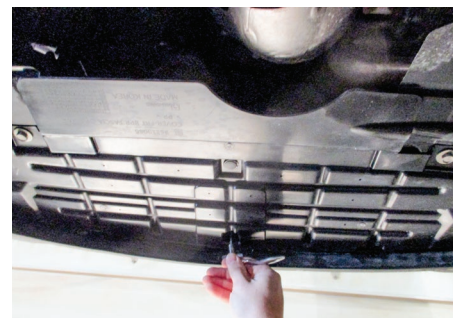
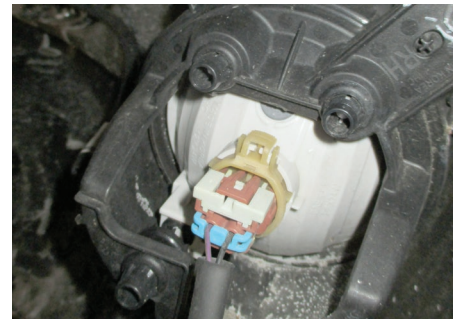
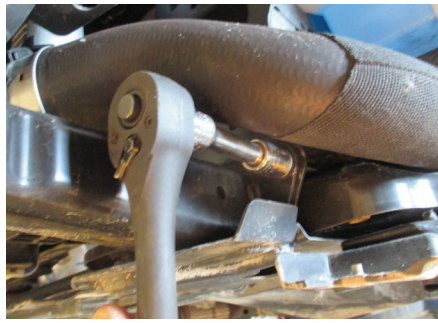

Final Installed Image



SAFETY CABLE INSTALLATION

Installing the Permanent Base Plate Safety Cables

When dinghy towing a vehicle with a tow bar, base plate safety cables should be used at all times. In the event of a disconnect, the safety cables are designed to help prevent complete vehicle separation. When installing the safety cables, use the illustrations below as a guide.

Installation guidelines

1. The cables must be connected to the base plate and the vehicle frame.
2. Two cables must be installed.
3. Each cable must meet or exceed the gross weight of the towed vehicle.
4. Make sure cables do not pinch or interfere with hoses, wiring or other components.

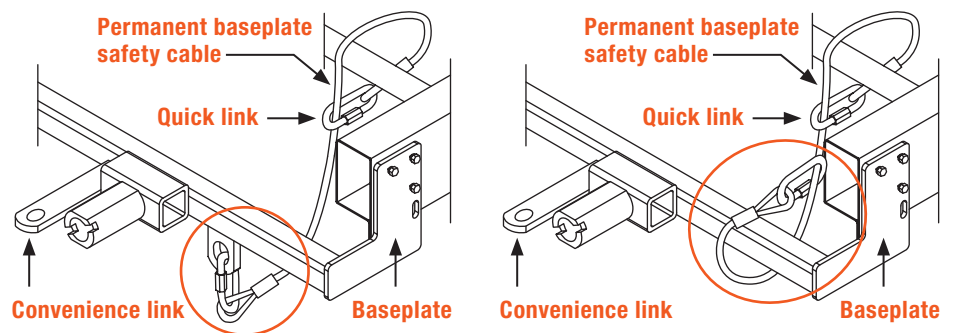

Note: Base plate safety cables are not a replacement for safety chains connecting the tow vehicle to the towed vehicle.

ADDITIONAL INFORMATION

Towing Tips

Check your equipment

Periodically check the condition of all towing equipment. Ensure all fasteners are tight and that all structural components are sound. Do not tow with worn or damaged parts.

Vehicle manufacturer's recommendations

Review the owner's manual for your towed vehicle and towing vehicle for specific recommendations, capacities and requirements.