

# INSTALLATION MANUAL

# 70115

## Level of Difficulty

Difficult

Installation difficulty levels are based on time and effort involved and may vary depending on the installer level of expertise, condition of the vehicle and proper tools and equipment.

## Installed Attachment Tabs

Height	16"
Width	19"

## Parts List

Item	Qty	Description
1	1	Tow bar base plate
2	2	Tow bar mounting tab
3	2	Safety cable, 3,500 lbs.
4	4	Carriage bolt, 3/8"-16 x 1-1/2", grade 8
5	4	Flange nut, 3/8"-16, grade 8
6	4	Hex bolt, 3/8"-16 x 1-1/4", grade 8
7	4	Nylock nut, 3/8"-16, grade 8
8	4	Conical washer, 3/8"
9	4	Square hole spacer, 1/4" x 1" x 2"
10	2	Quick link, 1/4"
11	2	Socket plug

## Tools Required

Torque wrench	Drill
Socket, 9/16"	Drill bit, 9/32"
Socket, 10mm	Drill bit, 13/32"
Socket, 12mm	Reciprocating saw
Hammer	Large vise grip
Utility knife	Phillips screwdriver
Hack saw blade	Flat head screwdriver
Clamps	Paint pen
Fishwire, 3/8" (includes four)	--

## ⚠ WARNING

Never exceed the vehicle manufacturer's recommended gross vehicle weight rating (GVWR).

## Product Photo



Not pictured: Safety cables, quick links and socket plugs

## ⚠ CAUTION

Take care when cutting any plastic or metal as injury may occur if done improperly.

## NOTICE

Visit website for a full-color copy of this instruction manual, as well as helpful videos, guides and much more!

Before you begin installation, read all instructions thoroughly.

Proper tools will improve the quality of installation and reduce the time required.

This installation requires front fascia panels, the air baffle, bumper, temperature sensor and windshield washer reservoir to be temporarily removed and reinstalled. Some drilling and trimming are also required.

To help prevent damage to the product or vehicle, refer to the specified torque specifications when securing hardware during the installation process.

If equipped, we recommend removing the base plate attachment tabs when not in use.

## SAFETY INSTRUCTIONS

Safety glasses should be worn at all times while installing this product.

# ASSEMBLY

## Parts List

Item	Qty	Description
1	1	Tow bar base plate
2	2	Tow bar mounting tab
3	2	Safety cable, 3,500 lbs.
4	4	Carriage bolt, 3/8"-16 x 1-1/2", grade 8
5	4	Flange nut, 3/8"-16, grade 8
6	4	Hex bolt, 3/8"-16 x 1-1/4", grade 8
7	4	Nylock nut, 3/8"-16, grade 8
8	4	Conical washer, 3/8"
9	4	Square hole spacer, 1/4" x 1" x 2"
10	2	Quick link, 1/4"
11	2	Socket plug

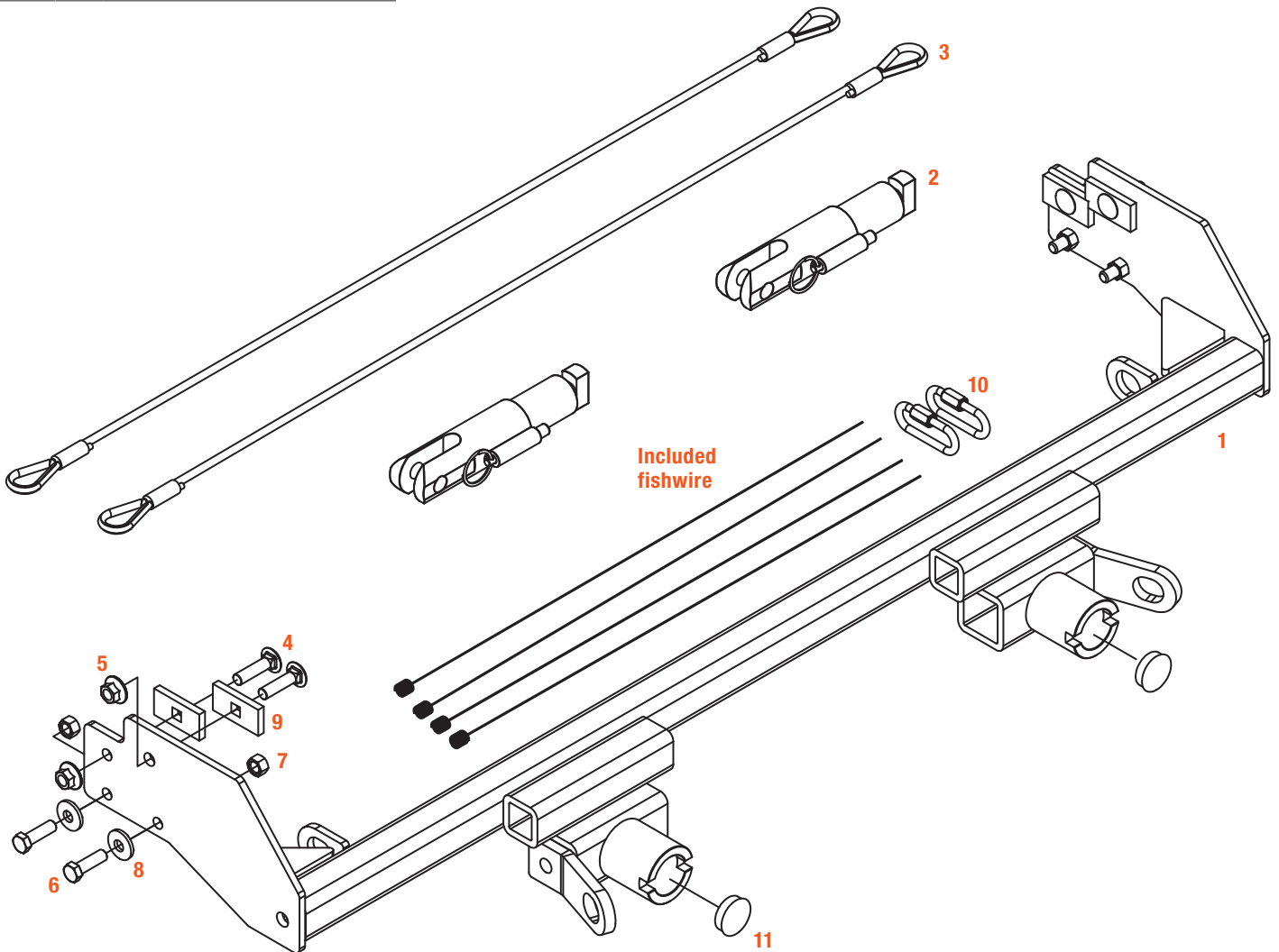

# BUMPER REMOVAL

## Step 1

Open the hood and remove the seven push pins from the top fascia cover. Pull the cover forward to remove it and set it aside.

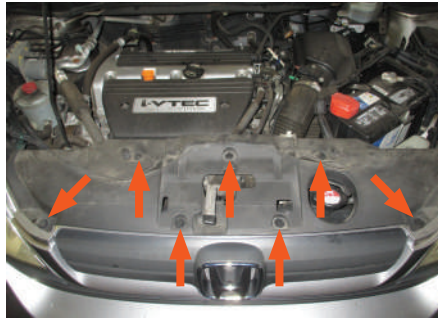

## Step 2

Remove the two Phillips screws and one push pin from the inside edge of the wheel well.

Repeat on the other side of the vehicle.



## Step 3

Use a 10mm socket to remove the underside bolt, just forward of the front tire.

Repeat on the other side of the vehicle.



#### Step 4

Remove the four push pins on the front underbody fascia panel. Then, remove the bumper cover and set it aside.

There are tabs securing the fascia panel to the bottom of the headlight assembly. You will need to use a pry tool to release the tabs, allowing you to remove the fascia cover.



#### Step 5

On the driver side, use a 10mm socket to remove the two bolts holding the air baffle in place. Remove the baffle by pulling it down and away from the vehicle. Then, set it aside.





### Step 6

On the passenger side, near the windshield washer reservoir, use a 10mm socket to remove the bolt holding the left-hand coolant line in place. Also, disconnect the clip above it. Then, disconnect the two clips from the right-hand coolant line.



### Step 7

Use a 10mm socket to remove the bolt in the coolant line bracket, near the bottom of the radiator.



### Step 8

On the driver side, just below the bumper, remove the clip holding the coolant line to the lower frame support. The clip should stay on the coolant line. Move the coolant line over toward the passenger side of the vehicle.

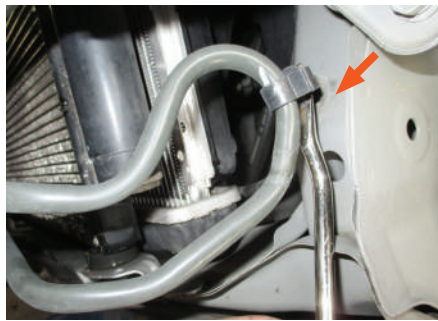

### Step 9

Use a paint pen to mark a notch in the frame end, as shown. Then, use a metal-cutting tool (reciprocating saw or cutoff wheel) to cut out the marked area.

Repeat on the other side of the vehicle.

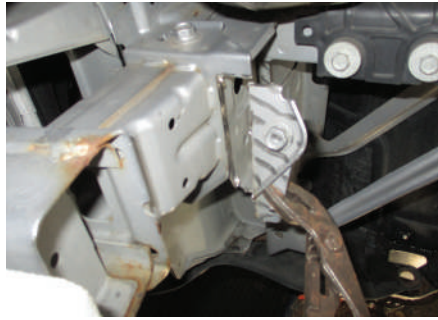
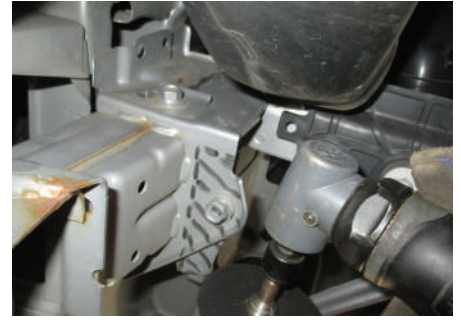
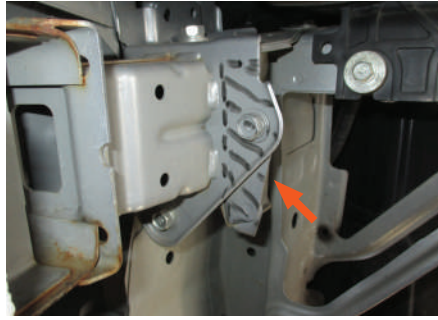

### Step 10

Mark two horizontal lines on the frame support, as shown, and use a metal-cutting tool to cut the marked lines. Then, use a hammer to carefully bend back the cut tab.

Repeat on the other side of the vehicle.





### Step 11

Mark a 1/4" wide area on the end of the bumper, flush with the side of the frame rail. Then, use a metal-cutting tool to cut off the marked area.

To inhibit rust, spray the cut off area with spray paint or a rust inhibitor.

Repeat on the other side of the vehicle.

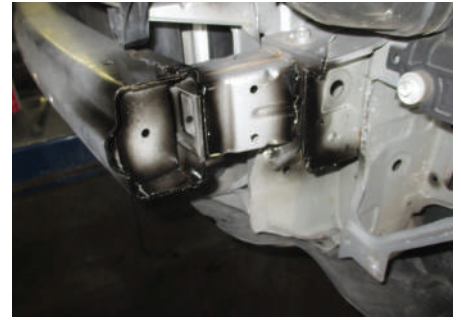

### Step 12

If present, remove the push pins holding the temperature sensor to the bottom of the bumper. Then, use a 12mm socket to remove the top and bottom bolts in the bumper support.

Repeat on the other side of the vehicle.

Carefully remove the bumper and set it aside.

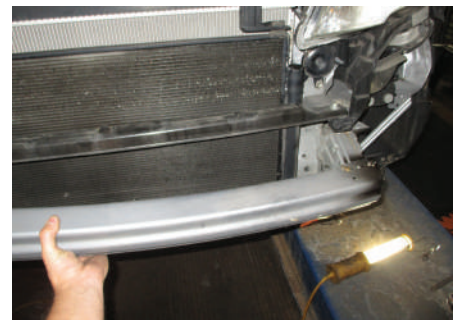
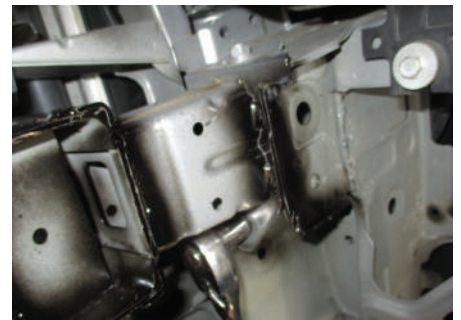
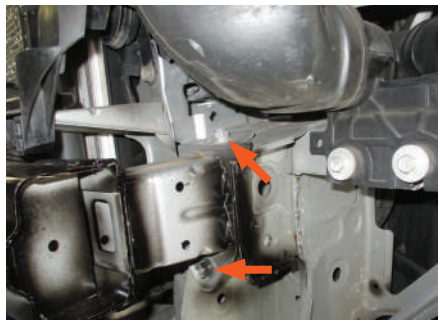

### Step 13

Use a 10mm socket to remove the bolts holding the windshield washer reservoir on the passenger side. Then, disconnect the fluid lines and set the reservoir aside.

**Note:** Be sure to have a clean container ready to catch the washer fluid when the lines are disconnected. Set the fluid aside to refill after the installation.

**On 2007-2009 models:** There will be one 10mm bolt on the side, holding the reservoir in place.

**On 2010 models:** There will be one 10mm bolt on the back side.





# TOW BAR BASE PLATE INSTALLATION

## Step 14

Position the tow bar base plate (#1) on the vehicle, aligning the bottom edge of the side plate with the bottom of the frame weld seam. Make sure the base plate is level and temporarily clamp it into place.

Then, drill four  $\frac{13}{32}$ " holes in the vehicle frame, using the side plate as a guide. Insert two  $\frac{3}{8}$ "-16 x 1- $\frac{1}{2}$ " carriage bolts (#4) and square hole spacers (#9) through the frame opening and position them into the top two holes in the side plate. Secure with two  $\frac{3}{8}$ " flange nuts (#5). Snug the hardware but do not fully tighten.

Reinstall the bumper using the factory hardware. Then, torque the  $\frac{3}{8}$ " bolts to 37 lb-ft.

Repeat on the other side of the vehicle.

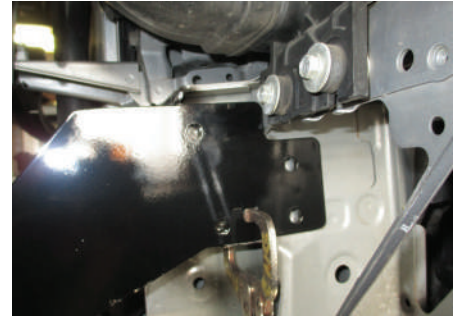



### Step 15

Install 3/8"-16 x 1 1/4" hex bolts (#6) with 3/8" conical washers (#8) and 3/8"-16 nylock nuts (#7) in the remaining two holes in the side plate.

Repeat on the other side of the vehicle and torque all hardware to 37 lb-ft.

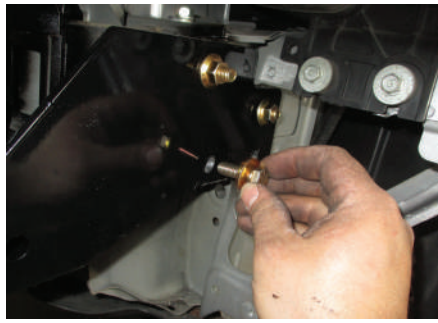

### Step 16

Relocate the bottom coolant line as shown by drilling a 9/32" hole just above the original hole in the bracket. Then, secure the bracket with factory bolt in the newly drilled hole. Bend excess bracket rearward for fascia clearance.

#### **⚠ WARNING**

Be sure there is adequate clearance around the coolant lines and that there is no contact with the base plate. Failure to do so may result in damage to the coolant lines and component failure. Lightly bend hard lines as needed to give proper clearance.

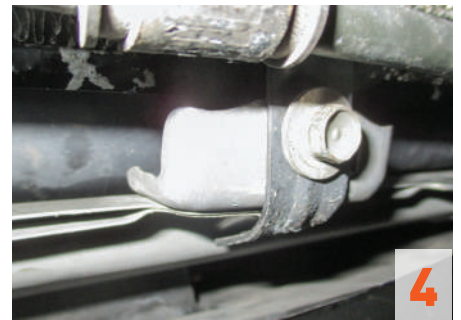
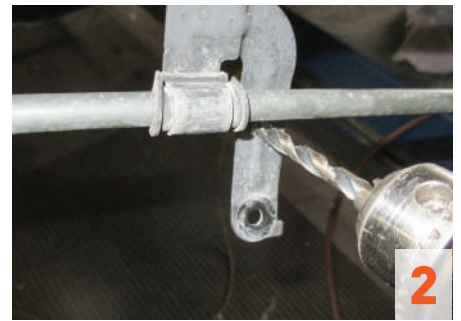
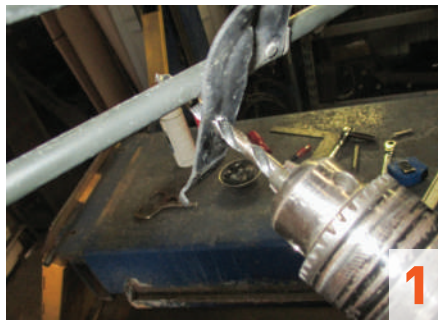



### Step 17

Install the permanent safety cables (#3) and quick links (#10), looping them around the vehicle frame and linking them to the tow bar base plate (#1). There must be one cable on each side of the vehicle.

Make sure the cables do not pinch or interfere with any hoses, wiring or other components.

See 'Installing the Permanent Base Plate Safety Cables' for additional information.

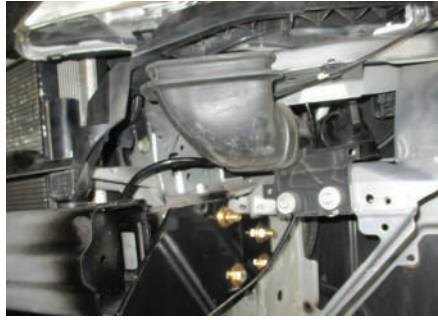

### Step 18

Reinstall the windshield washer reservoir, temperature sensor, air baffle and coolant line clips. Trim the top bolt on the driver side if needed for air baffle clearance.

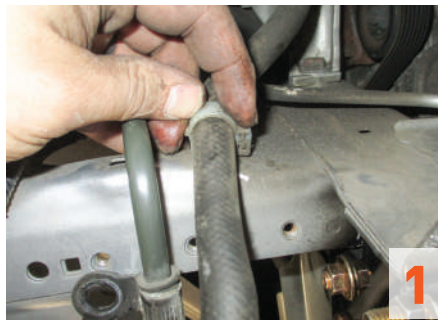



## Step 19

Hold up the front fascia in its original position and mark where it will need to be trimmed to make space for the relocated coolant lines, safety cable loops and attachment tabs. Trim off the marked areas. Then, reinstall the fascia.

**For 2010 models:** Trim off the two outside bars complete on both side of the vehicle. Then, reinstall the fascia.

When ready to tow, install the tow bar mounting tabs (#2). When not towing, insert the socket plugs (#11) into the ends of the base plate (#1).



## Final Installed Image



# SAFETY CABLE INSTALLATION

## Installing the Permanent Base Plate Safety Cables

When dinghy towing a vehicle with a tow bar, base plate safety cables should be used at all times. In the event of a disconnect, the safety cables are designed to help prevent complete vehicle separation. When installing the safety cables, use the illustrations below as a guide.

### Installation guidelines

1. The cables must be connected to the base plate and the vehicle frame.
2. Two cables must be installed.
3. Each cable must meet or exceed the gross weight of the towed vehicle.
4. Make sure cables do not pinch or interfere with hoses, wiring or other components.

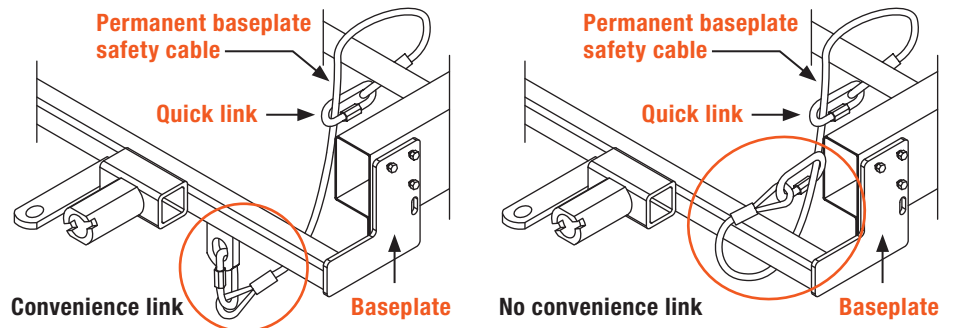

**Note:** Base plate safety cables are not a replacement for safety chains connecting the tow vehicle to the towed vehicle.

## Towing Tips

### Check your equipment

Periodically check the condition of all towing equipment. Ensure all fasteners are tight and that all structural components are sound. Do not tow with worn or damaged parts.

### Vehicle manufacturer's recommendations

Review the owner's manual for your towed vehicle and towing vehicle for specific recommendations, capacities and requirements.