

INSTALLATION MANUAL

70109

Level of Difficulty

Moderate

Installed Attachment Tabs

Height	15-1/2"
Width	24"

Parts List

Item	Qty	Description
1	1	Tow bar base plate
2	2	Tow bar mounting tab
3	2	Safety cable, 3,500 lbs.
4	2	Spacer plate, 10-gauge
5	4	Hex head cap screw, 1/4"-20 x 3/4", grade 8
6	4	Nylock nut, 1/4"
7	6	Flange nut, 3/8"
8	2	Nylock nut, 3/8"
9	2	Conical washer, 3/8"
10	2	Hex head cap screw, 3/8"-16 x 1-1/2", grade 8
11	6	Carriage bolt, 3/8"-16 x 2", grade 8
12	6	Square hole spacer, 1/4" x 1" x 2"
13	6	Flat washer, 3/8"
14	2	Quick link, 1/4"
15	2	Socket plug

Tools Required

Torque wrench	Drill
Socket, 9/16"	Drill bit, 13/32"
Socket, 7/16"	T20 Torx bit
Socket, 7mm	Utility knife
Socket, 10mm	Large vice grip
Wrench, 7/16"	Tape measure
Wrench, 9/16"	Phillips screwdriver
Reciprocating saw	Fishwire, 1/2" (includes six)

⚠ WARNING

Never exceed the vehicle manufacturer's recommended gross vehicle weight rating (GVWR).

Product Photo



Not pictured: Safety cables, quick links and socket plugs

⚠ CAUTION

Take care when cutting any plastic or metal as injury may occur if done improperly.

NOTICE

Before you begin installation, read all instructions thoroughly.

Proper tools will improve the quality of installation and reduce the time required.

This installation requires fascia and the air baffle to be temporarily removed and reinstalled. Some drilling and trimming are required.

To help prevent damage to the product or vehicle, refer to the specified torque specifications when securing hardware during the installation process.

If equipped, we recommend removing the base plate attachment tabs when not in use.

Torque Specifications

Metric	Bolt Size	CL8.8	CL10.9	SAE	Bolt Size	Grade 5	Grade 8
	M6 bolt	6.6 ft-lbs.	9.4 ft-lbs.		1/4" bolt	86 in-lbs.	122 in-lbs.
M8 bolt	16.0 ft-lbs.	22.9 ft-lbs.	5/16" bolt	178 in-lbs.	251 in-lbs.		
M10 bolt	31.6 ft-lbs.	45.2 ft-lbs.	3/8" bolt	26 ft-lbs.	37 ft-lbs.		
M12 bolt	55.1 ft-lbs.	78.9 ft-lbs.	7/16" bolt	42 ft-lbs.	59 ft-lbs.		
M14 bolt	88.1 ft-lbs.	126.1 ft-lbs.	1/2" bolt	75 ft-lbs.	110 ft-lbs.		
M16 bolt	136.7 ft-lbs.	195.6 ft-lbs.	5/8" bolt	128 ft-lbs.	180 ft-lbs.		
M18 bolt	195.4 ft-lbs.	270.3 ft-lbs.	3/4" bolt	227 ft-lbs.	320 ft-lbs.		

Use above torque setting unless otherwise noted

ASSEMBLY

Parts List

Item	Qty	Description
1	1	Tow bar base plate
2	2	Tow bar mounting tab
3	2	Safety cable, 3,500 lbs.
4	2	Spacer plate, 10-gauge
5	4	Hex head cap screw, 1/4"-20 x 3/4", grade 8
6	4	Nylock nut, 1/4"
7	6	Flange nut, 3/8"
8	2	Nylock nut, 3/8"
9	2	Conical washer, 3/8"
10	2	Hex head cap screw, 3/8"-16 x 1-1/2", grade 8
11	6	Carriage bolt, 3/8"-16 x 2", grade 8
12	6	Square hole spacer, 1/4" x 1" x 2"
13	6	Flat washer, 3/8"
14	2	Quick link, 1/4"
15	2	Socket plug

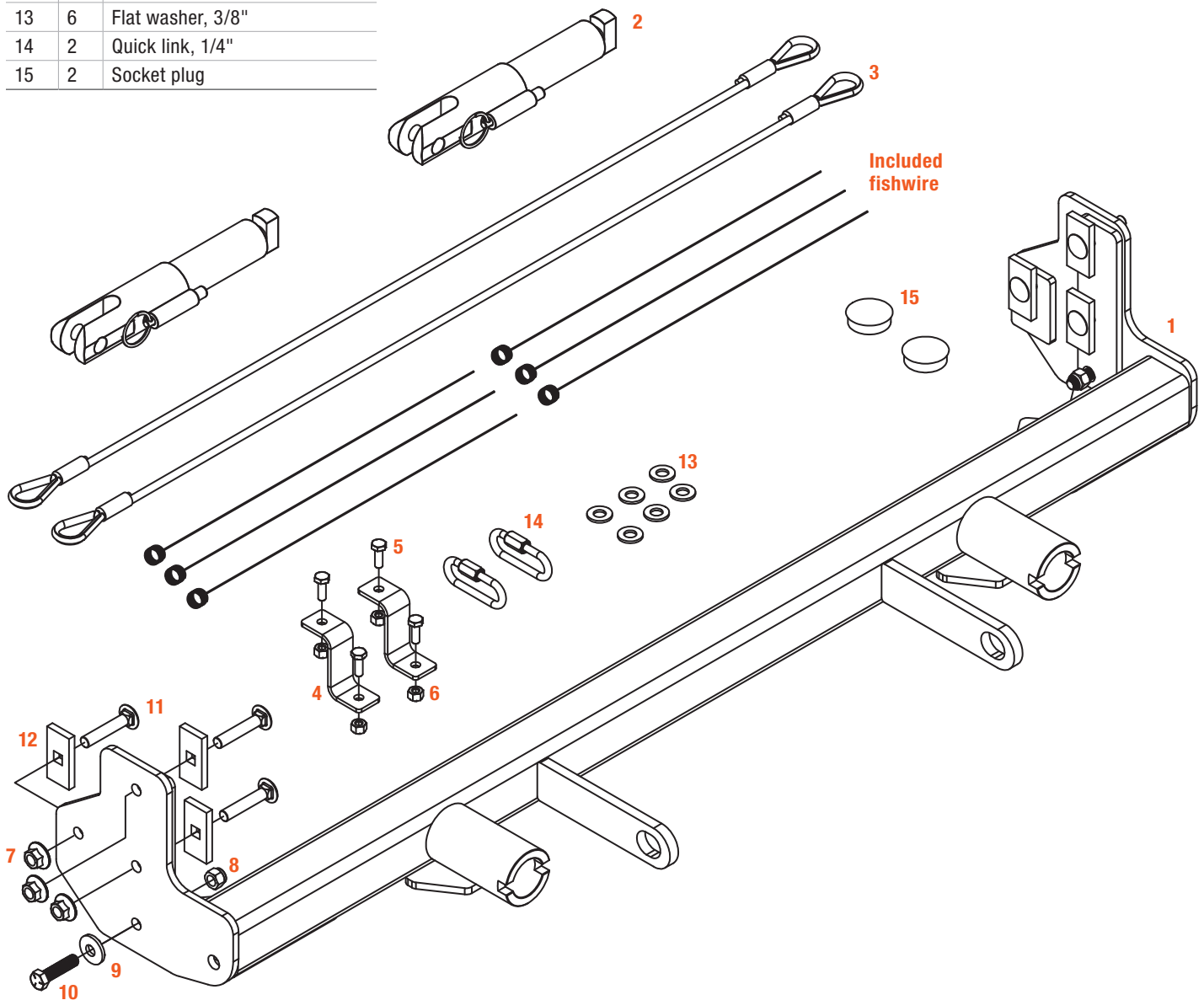

FASCIA REMOVAL

Step 1

Open the hood and use a T20 Torx bit to remove the four screws from the grille attachment panel – two on each side of the vehicle.

Remove the four push pins on the outer radiator cover panel – two on each side.

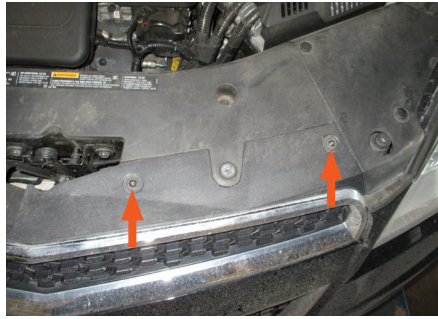

Step 2

Use a T20 Torx bit to remove the two screws along the front edge of the wheel well liner. Also remove the two push pins in the liner.

Repeat on the other side of the vehicle.

For 2014-2017 Equinox: Use a 7mm socket to remove the additional screw in the liner.



Step 3

Use a 7mm socket to remove the four underside screws along the outer edge of the front fascia – two on each side of the vehicle.



Step 4

Starting on the outer edges, pull the fascia panel out while using a non-marring pry tool to release the clips from each fender.

Work your way toward the center of the vehicle, unclipping the bumper cover. Make sure to unplug any wiring harnesses attached to the bumper cover as necessary.

Carefully remove the bumper cover and set it aside so it will not be damaged during the rest of the installation.



TOW BAR BASE PLATE INSTALLATION

Step 5

Use a 10mm socket to remove the two nuts holding the air baffle in place on the passenger side.

For 2014-2017 models: Use a 10mm socket to remove the two bolts in the bumper reinforcement on the driver side. Use a 15mm socket to remove the two remaining bolts inset in the reinforcement.

Remove the reinforcement and return it and the hardware for it to the vehicle owner.

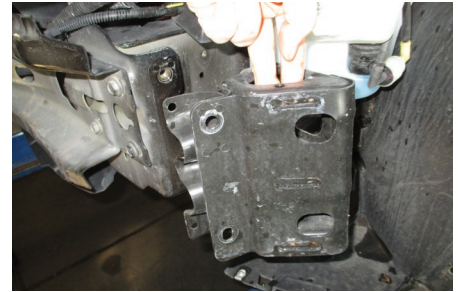
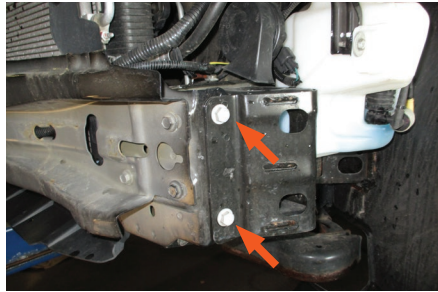
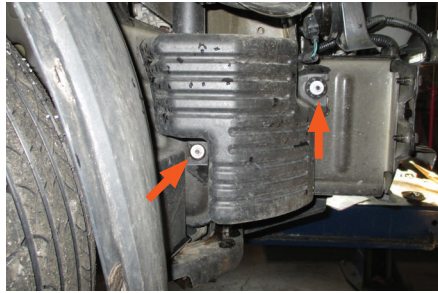

Step 6

Mark the areas on the frame that need to be trimmed flush with the outer edge of the frame rail and up to the bumper seam (pictured).

Cut off the marked area with a metal cutting tool (reciprocating saw or cutoff wheel).

Repeat on the other side of the vehicle.

For 2014-2017 models: An additional portion of the frame will need to be trimmed off as shown in the bottom image.



Step 7

Using a vice grips, carefully bend the outside flanges of the bumper outward to at least 90 degrees.

Repeat on the other side of the vehicle.

For models with an auxiliary cooler, remove the two bolts and move the cooler down (not pictured).



Step 8

Unclip the temperature sensor on the grille and move it up by the bumper so it will not be damaged when the base plate is moved into position.

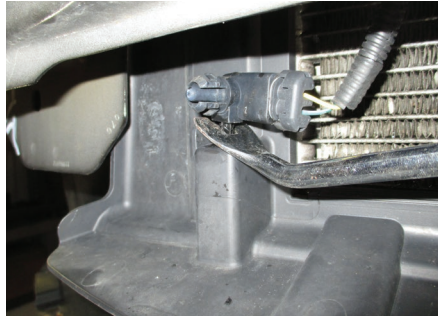

Step 9

Mark the top portion of the temperature sensor mount about 5/8" high x 1/2" deep. Use a utility knife to trim off the marked area.

For 2016-2017 models: Mark and trim off the outside portion of the lower plastic piece on both sides of the vehicle to make clearance for the base plate.



Step 10

Slide the tow bar base plate (#1) onto the vehicle so the frame rail rib is between the spacers on the plate. There should be 1-1/8" clearance between the top edge of the side plates and the top edge of the vehicle frame. Make sure the base plate is level and temporarily clamp it into place.

Using the top hole in the side plate as a guide, drill a 13/32" hole in the vehicle frame.

Fishwire a 3/8" carriage bolt (#11) and 1/4" square hole spacer (#12) through the access hole in the bottom of the frame into the hole. Loosely install a 3/8" flange nut (#7) and repeat on the other side of the vehicle.

Make sure the base plate is level, torque the hardware to 37 lb-ft.

On 2015-2017 models: The lower flange of the bumper may require trimming to make space for the safety cable loops and attachment tabs.

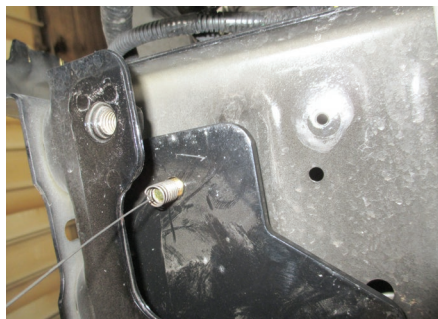

Step 11

Use a 13/32" drill bit to drill out the remaining three holes in the vehicle frame. **Note:** On the driver side, the rearward hole will have a weldnut behind it that will need to be removed after drilling.

Fishwire a 3/8" carriage bolt (#11) into both of the upper holes and secure them with a 3/8" flange nut (#7). For the bottom-most hole, insert a 3/8" hex head cap screw (#10) and conical washer (#9) through the base plate (#1) and tighten with a 3/8" nylock nut (#8).

Repeat on the other side of the vehicle.

Torque the hardware to 37 lb-ft.

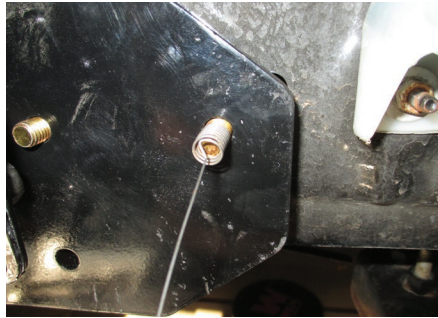
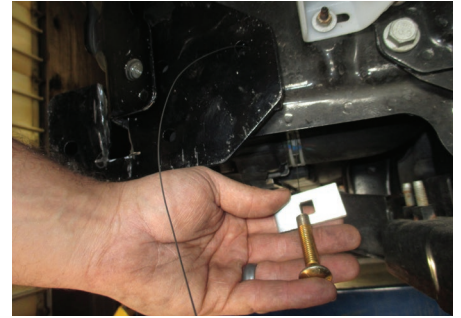

Step 12

Place three 3/8" flat washers (#13) on each mounting stud for the air baffle.

Reinstall the baffle.



Step 13

Install the permanent safety cables (#3) and quick links (#14), looping them around the vehicle frame and linking them to the tow bar base plate (#1). There must be one cable on each side of the vehicle. Make sure the cables do not pinch or interfere with any hoses, wiring or other components.

See 'Installing the Permanent Base Plate Safety Cables' for additional information.

Step 14

For 2010-2015 Terrain: Mark and trim the corner inside the bumper cover toward the grille opening where the black lower plastic trim meets the body colored fascia as needed to ensure base plate clearance.

Repeat on the other side of the vehicle. Skip to Step 20.

Step 15

For 2016-2017 Terrain: Mark and trim the area (approximately 1-1/2") of the styrofoam bumper padding and fascia as needed, roughly flush with the bumper padding attachment clip on the cover. An additional portion of the bumper cover seam directly below it may also need to be trimmed for proper fitment.

Skip to Step 20.

Step 16

For 2010-2013 Equinox: Trim the inner edges of the black plastic lower grille opening at the bottom about 1" and taper upward to the top edge as needed.

Skip to Step 20.

Step 17

For 2014 Equinox: Mark and trim off the corner of the styrofoam bumper padding above the lower grille opening.

Mark and trim out the side of the lower grille opening on the outer edges, following the edge around. Also, trim back the seam in the area between the tabs next to the lower grille opening only as needed to provide extra clearance for the base plate.



Step 18

For 2015-2017 Equinox: Mark and trim the outer most lower tab from the styrofoam bumper padding above the opening as needed.

Mark and trim the side of the lower grille opening about 1" as needed.

Step 19

If previously removed, relocate the cooler using the supplied spacer plate (#4) and 1/4" hex head cap screws (#5) and nylock nuts (#6) raising the cooler above the base plate in front of the radiator.



Step 20

Reinstall the temperature sensor, any fascia and other components that were removed during the install.

When ready to tow, install the tow bar mounting tabs (#2). When not towing, insert the socket plugs (#15) into the ends of the tow bar base plate (#1).



Final Installed Image



SAFETY CABLE INSTALLATION

Installing the Permanent Base Plate Safety Cables

When dinghy towing a vehicle with a tow bar, base plate safety cables should be used at all times. In the event of a disconnect, the safety cables are designed to help prevent complete vehicle separation. When installing the safety cables, use the illustrations below as a guide.

Installation guidelines

1. The cables must be connected to the base plate and the vehicle frame.
2. Two cables must be installed.
3. Each cable must meet or exceed the gross weight of the towed vehicle.
4. Make sure cables do not pinch or interfere with hoses, wiring or other components.

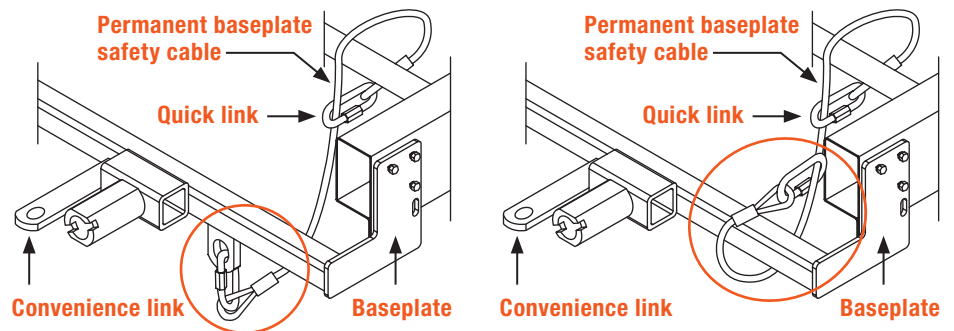

Note: Base plate safety cables are not a replacement for safety chains connecting the tow vehicle to the towed vehicle.

ADDITIONAL INFORMATION

Towing Tips

Check your equipment

Periodically check the condition of all towing equipment. Ensure all fasteners are tight and that all structural components are sound. Do not tow with worn or damaged parts.

Towing vehicle and trailer manufacturer's recommendations

Review the owner's manual for your towing vehicle and trailer for specific recommendations, capacities and requirements.