

# INSTALLATION MANUAL

# 70101

## Level of Difficulty

Moderate

## Installed Attachment Tabs

Height	17-1/2"
Width	34-3/4"

## Parts List

Item	Qty	Description
1	1	Tow bar base plate, passenger
2	1	Tow bar base plate, driver
3	4	Conduit, 1/2", short
4	4	Conduit, 1/2", long
5	2	Plate, 1/4", small
6	2	Support plate, 1/4", large
7	4	Flat washer, 3/16", black
8	2	Tow bar mounting tab
9	2	Safety cable, 7,500 lbs.
10	2	Quick link, 1/2"
11	4	Carriage bolt, 3/8"-16, 1-1/2", grade 8
12	8	Flange nut, 3/8"-16, grade 8
13	4	Hex head cap screw, 3/8"-16, 1-1/4", grade 8
14	4	Nylock nut, 3/8"-16, grade 8
15	4	Hex head cap screw, M10 x 1.5", 80mm, CL8.8
16	8	Conical washer, 7/16"
17	4	Hex head cap screw, 3/8"-16, 4-1/2", grade 8
18	3	Flat washer, 3/8"
19	4	Nylon rivet
20	4	Hex head cap screw, M10 x 1.5", 100mm, CL10.9
21	2	Socket plug

## Tools Required

Torque wrench	Drill
Socket, 9/16"	Drill bit, 1/4"
Socket, 8mm	Drill bit, 3/8"
Socket, 10mm	Wrench, 9/16"
Socket, 16mm	Wrench, 30mm
Socket, 30mm	Tape measure
Plastic pop rivet gun	Large vise grip
Flat screwdriver	Utility knife
Fishwire, 3/8" (includes four)	

## ⚠ WARNING

Never exceed the vehicle manufacturer's recommended gross vehicle weight rating (GVWR).

## Product Photo



Not pictured: Safety cables, quick links, socket plugs and nylon rivets

## ⚠ CAUTION

Take care when cutting any plastic or metal as injury may occur if done improperly.

## NOTICE

Before you begin installation, read all instructions thoroughly.

Proper tools will improve the quality of installation and reduce the time required.

This installation requires front fascia panels and windshield washer components to be temporarily removed and reinstalled. Some drilling and trimming are required.

For vehicles with tow hooks, the tow hooks must be removed and not reinstalled.

To help prevent damage to the product or vehicle, refer to the specified torque specifications when securing hardware during the installation process.

If equipped, we recommend removing the base plate attachment tabs when not in use.

## Torque Specifications

	Bolt Size	Metric		SAE	Bolt Size	Grade 5	Grade 8
		CL8.8	CL10.9				
Metric	M6 bolt	6.6 ft-lbs.	9.4 ft-lbs.	SAE	1/4" bolt	86 in-lbs.	122 in-lbs.
	M8 bolt	16.0 ft-lbs.	22.9 ft-lbs.		5/16" bolt	178 in-lbs.	251 in-lbs.
	M10 bolt	31.6 ft-lbs.	45.2 ft-lbs.		3/8" bolt	26 ft-lbs.	37 ft-lbs.
	M12 bolt	55.1 ft-lbs.	78.9 ft-lbs.		7/16" bolt	42 ft-lbs.	59 ft-lbs.
	M14 bolt	88.1 ft-lbs.	126.1 ft-lbs.		1/2" bolt	75 ft-lbs.	110 ft-lbs.
	M16 bolt	136.7 ft-lbs.	195.6 ft-lbs.		5/8" bolt	128 ft-lbs.	180 ft-lbs.
	M18 bolt	195.4 ft-lbs.	270.3 ft-lbs.		3/4" bolt	227 ft-lbs.	320 ft-lbs.

Use above torque setting unless otherwise noted

# ASSEMBLY

## Parts List

Item	Qty	Description
1	1	Tow bar base plate, passenger
2	1	Tow bar base plate, driver
3	4	Conduit, 1/2", short
4	4	Conduit, 1/2", long
5	2	Plate, 1/4", small
6	2	Support plate, 1/4", large
7	4	Flat washer, 3/16", black
8	2	Tow bar mounting tab
9	2	Safety cable, 7,500 lbs.

## Parts List

Item	Qty	Description
10	2	Quick link, 1/2"
11	4	Carriage bolt, 3/8"-16, 1-1/2", grade 8
12	8	Flange nut, 3/8"-16, grade 8
13	4	Hex head cap screw, 3/8"-16, 1-1/4", grade 8
14	4	Nylock nut, 3/8"-16, grade 8
15	4	Hex head cap screw, M10 x 1.5", 80mm, CL8.8

## Parts List

Item	Qty	Description
16	8	Conical washer, 7/16"
17	4	Hex head cap screw, 3/8"-16, 4-1/2", grade 8
18	3	Flat washer, 3/8"
19	4	Nylon rivet
20	4	Hex head cap screw, M10 x 1.5", 100mm, CL10.9
21	2	Socket plug

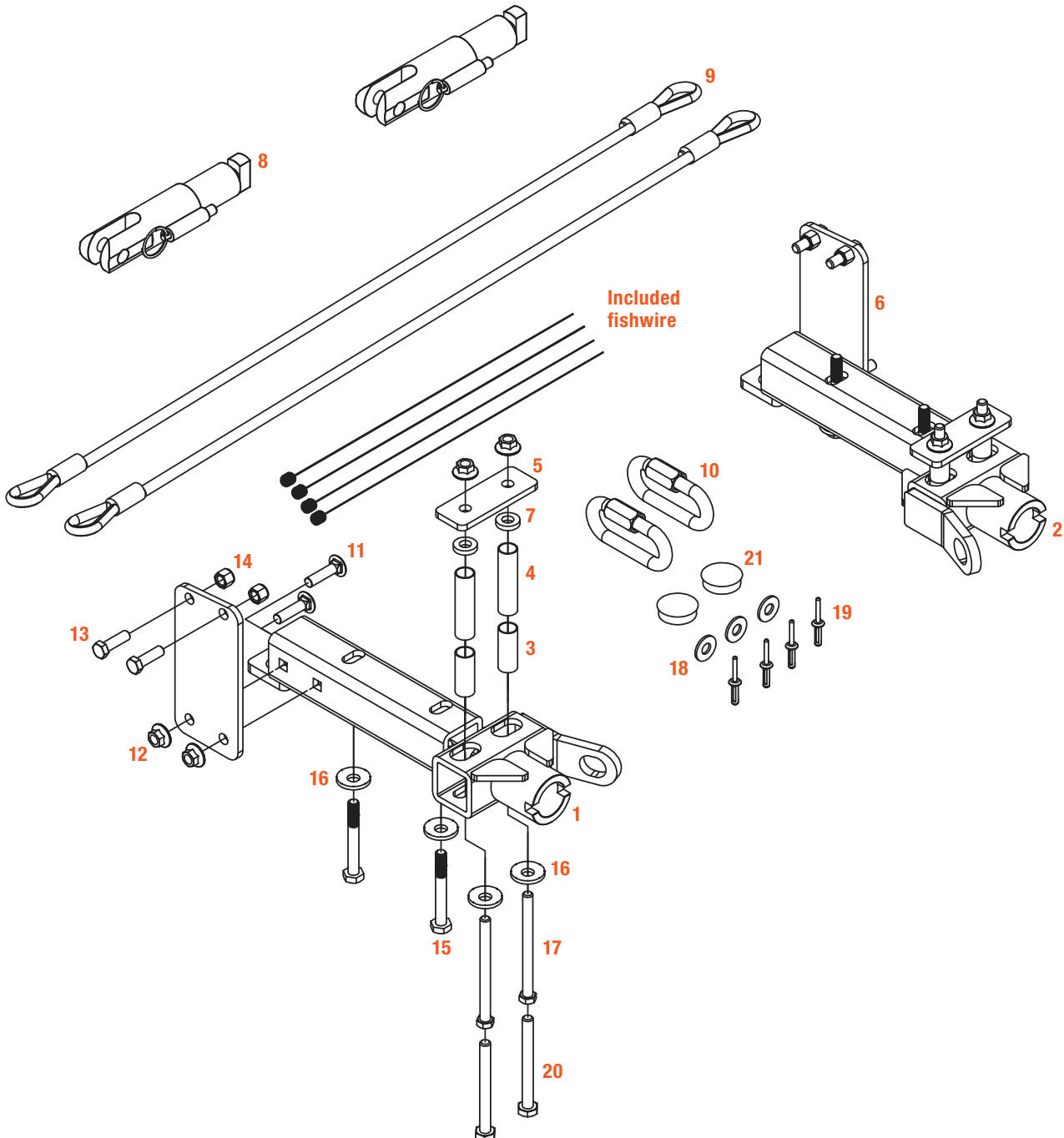

# FASCIA REMOVAL

## 2011-2013 DURANGO AND GRAND CHEROKEE

### Step 1

Remove the four retainer pins on the underside of the front fascia panel.

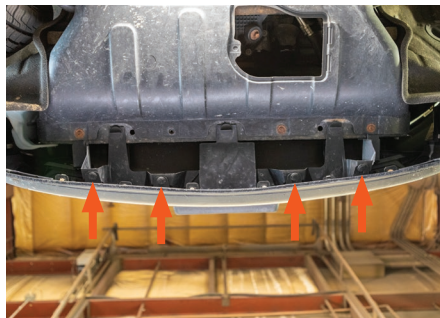

### Step 2

Remove the two plastic rivets from the front edge of the wheel well liner. Turn and release the retainer knob at the bottom edge of the liner.

Repeat on the other side of the vehicle.



### Step 3

Using a 10mm socket, remove the wheel well liner bolt. Then, remove the final retainer pin above the bolt.

Repeat on the other side of the vehicle.



# 2011-2013 DURANGO AND GRAND CHEROKEE (CONTINUED)

## Step 4

Carefully pull back the wheel well trim. Then, starting on the outer edge, pull the bumper cover out, releasing the clips. Work your way toward the center of the vehicle, unclipping the bumper cover.

If the vehicle is equipped with fog lights, unplug them prior to bumper removal. Once removed, set the panel aside.

Proceed to Step 11 to continue installation.

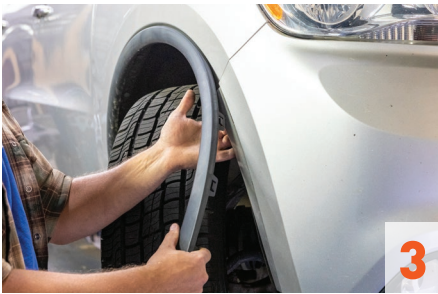

## 2014+ GRAND CHEROKEE

### Step 5

Open the hood and remove the two retainer pins holding the front, upper fascia in place.

### Step 6

Remove the two plastic rivets from the front edge of the wheel well liner. Then, remove the bolt above the rivets with a 10mm socket.

Repeat on the other side of the vehicle.

### Step 7

Remove the four retainer pins holding the fascia to the bumper.

### Step 8

Turn and release the four retainer knobs on the underside of the fascia, two on the outside and two near the center.

### Step 9

If the vehicle is equipped with headlight sprayers, pull the square access panels out to disconnect the sprayers on each side of the vehicle. Push the clips down to disconnect the brackets.

Set the removed components aside.

### Step 10

Starting on the outer edges, pull the fascia panel out, releasing the clips. Work your way toward the center of the vehicle, unclipping the fascia. If the vehicle is equipped with fog lights, unplug them prior to bumper removal. Once removed, set the panel aside.

**Note:** On Summit and High Altitude models, the corner clips must be released by pushing inward first, then pulling down and out.

# TOW BAR BASE PLATE INSTALLATION

## NOTICE

It is your responsibility to watch for oil cooler and air conditioner lines, electrical wires and hoses, and missing parts or attaching points on the frame. If the baseplate is improperly installed and is against a wire or hose, it could cause fluid leaks or electrical shorts some time after the actual baseplate installation.

## Step 11

If your vehicle has the two smaller, bottom, outside fascia panels, remove them using a 10mm socket. Remove the three bolts holding each panel in place on either side of the vehicle.

## Step 12

Open the hood and remove the retainer pin holding the windshield washer refill tube in place.



## Step 13

Use an 8mm socket to remove the top and bottom bolts holding the windshield washer reservoir in place.

Then, remove any necessary tubes and connections, and set the reservoir aside.

**Note:** Be sure to have a clean container ready to catch the washer fluid when the lines are disconnected. Set the fluid aside to refill after the installation.



## Step 14

On the passenger side, use a 10mm or 13mm socket to remove the compressor if equipped. There are two nuts attaching the compressor to the bumper and one attaching it to the vehicle's frame. Remove these, making sure to support the compressor while it is temporarily removed.

Insert the threaded inner stud into the outer bumper hole, making space for the base plate. Secure with a nut.

# MODELS WITH TOW HOOKS

## Step 15

If your vehicle is equipped with tow hooks, they will need to be permanently removed. Starting at the front, remove the two bolts with a 16mm socket. Next, remove the rear nut using a 30mm socket. Remove the tow hook, and repeat on the other side.

## Step 16

Use a 16mm socket to remove the two bolts on the tow hook bracket. Remove the bracket and repeat on the other side of the vehicle. Return the tow hooks and hardware to the vehicle's owner.

## Step 17

On the passenger side, insert the tow bar base plate (#1) into the vehicle frame opening, and install two M10-1.5 x 80mm hex head cap screws (#15) with 7/16" conical washers (#16) in the bottom, rearward holes.

Then, position two short conduit spacers (#3) inside the front tow bar base plate tube (#1).

Insert one M10-1.5 x 100mm hex head cap screw (#20) with 7/16" conical washers (#16) into each hole in the base plate, passing the bolts through the conduit spacers (#3).

Repeat on the driver side of the vehicle and torque the hardware to 45 lb-ft.

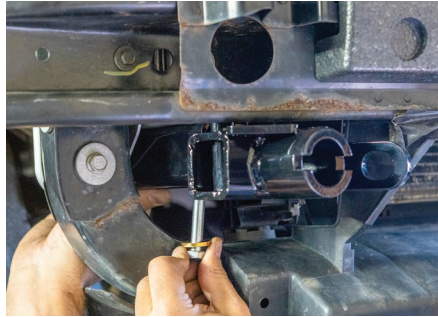

# MODELS WITHOUT TOW HOOKS

## Step 18

If applicable, remove fascia tow hook opening covers.

On the passenger side, insert the tow bar base plate (#1) into the vehicle frame opening and install two M10-1.5 x 80mm hex head cap screws (#15) with 7/16" conical washers (#16) in the bottom, rearward holes.

Then, position two long conduit spacers (#4) inside the front tow bar base plate tube (#1).

Insert a 3/8"-16 x 4-1/2" hex head cap screws (#17) with 7/16" conical washers (#16) into each hole in the base plate, passing the screws through the long conduit spacers (#4), the bumper beam and the small plate (#5).

Secure them with 3/8"-16 flange nuts (#12) on top of the frame. If needed, place a 3/16" thick, black flat washer (#7) between the bumper and the conduit spacer (#4).

Repeat on the driver side of the vehicle and torque the hardware to 37 lb-ft.

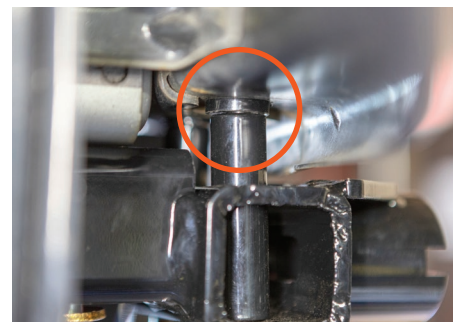
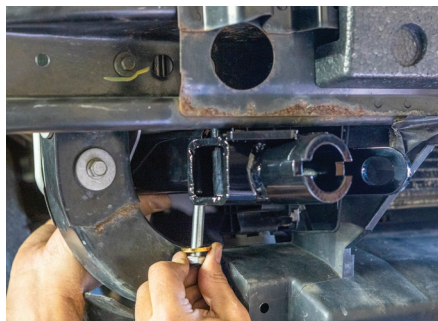
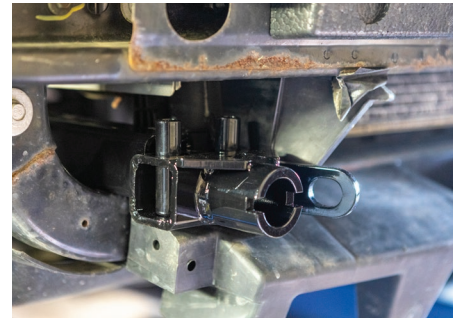

# MODELS WITHOUT TOW HOOKS (CONTINUED)

## Step 19

On the passenger side, fishwire two 3/8"-16 x 1-1/2" carriage bolts (#11) through the base plate tube. Place the support plate (#6) over the bolts, making sure the taper is toward the front of the vehicle.

Loosely secure the bolts with 3/8" flange nuts (#12).

Repeat on the driver side of the vehicle and torque the hardware to 37 lb-ft.

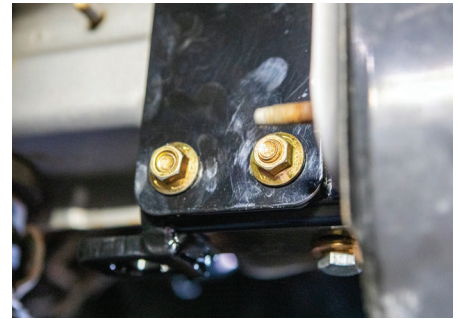
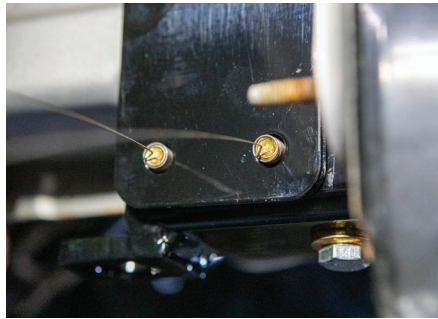
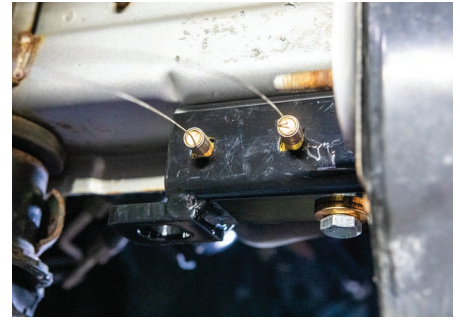

## Step 20

Using the top holes of the support plate (#6) as a guide, drill two 3/8" holes in the upper pinch flange seam of the vehicle frame.

Insert 3/8"-16 x 1-1/4" hex head cap screws (#13) and secure with 3/8"-16 nylock nuts (#14).

Repeat on the other side of the vehicle and torque the hardware to 37 lb-ft.



## Step 21

Install the permanent safety cables and quick links (#9, #10), looping them around the vehicle frame and linking them to the tow bar base plates (#1, #2). There must be one cable on each side of the vehicle.

Make sure the cables do not pinch or interfere with any hoses, wiring or other components. See 'Installing the Permanent Base Plate Safety Cables' for additional information.

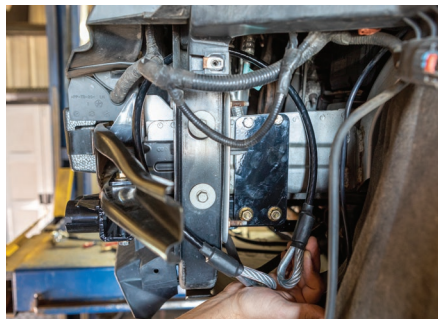

# MODELS WITHOUT TOW HOOKS (CONTINUED)

## Step 22

Reinstall the compressor, making sure it clears the tow bar base plate and will not vibrate against it. Use 3/8" washers (#18) as shim to add clearance if necessary.

Reattach the windshield washer reservoir.



## Step 23

Hold up the fascia in its original position and mark where / if the fascia will need to be trimmed to make space for the safety cable loops and attachment tabs. Trim off the marked area.

Reinstall the fascia. Install two rivets (#19) in each wheel well liner, using a rivet gun.

**Note:** For Summit and High Altitude models without tow hook pockets in the fascia, we recommend trimming a smaller area for the safety cable loops and attachment tabs. Then, do a test fit and trim again as needed.



## Step 24

Reinstall any fascia and other components that were removed during the install.

When ready to tow, install the tow bar mounting tabs (#8). When not towing, insert the socket plugs (#21) into the ends of the tow bar base plates (#1,#2).



## Final Installed Image



# SAFETY CABLE INSTALLATION

## Installing the Permanent Base Plate Safety Cables

When dinghy towing a vehicle with a tow bar, base plate safety cables should be used at all times. In the event of a disconnect, the safety cables are designed to help prevent complete vehicle separation. When installing the safety cables, use the illustrations below as a guide.

### Installation guidelines

1. The cables must be connected to the base plate and the vehicle frame.
2. Two cables must be installed.
3. Each cable must meet or exceed the gross weight of the towed vehicle.
4. Make sure cables do not pinch or interfere with hoses, wiring or other components.

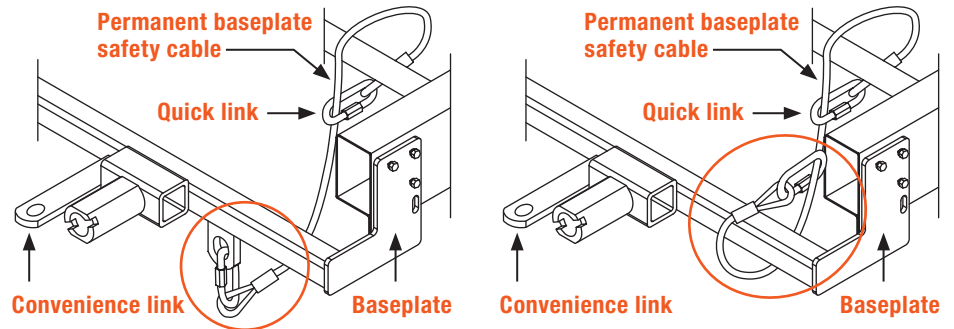

**Note:** Base plate safety cables are not a replacement for safety chains connecting the tow vehicle to the towed vehicle.

## ADDITIONAL INFORMATION

### Towing Tips

#### Check your equipment

Periodically check the condition of all towing equipment. Ensure all fasteners are tight and that all structural components are sound. Do not tow with worn or damaged parts.

#### Vehicle manufacturer's recommendations

Review the owner's manual for your towed vehicle and towing vehicle for specific recommendations, capacities and requirements.