

# INSTALLATION MANUAL

# 70001

## Level of Difficulty

Easy

## Weight Capacity

Gross vehicle weight rating 7,500 lbs.

## Parts List

Item	Qty	Description
1	1	Tow bar
2	2	Safety cable, 7'
3	1	Hitch pin & clip

## Tools Required

None

## Maintenance

Check fasteners before each use. After every 1,000 miles re-torque fasteners. See 'Tow Bar Terminology' on page 2.

Check your towing system after any unusual event and periodically on a long trip.

Clean the tow bar after each use with warm soapy water and dry with towels. We recommend the tow bar be removed from the vehicle or covered when not in use.

If the arms become difficult to move in and out, remove the zip tie securing the rubber bellow and slide it back. Clean the inner rods with a silicone spray or brake cleaner. Apply a light coating of multipurpose grease to each rod and actuate in and out until it slides smoothly. Re-secure each bellow with a UV-rated nylon zip tie. If the rubber bellows are cracked or damaged replace them immediately.

## ⚠ WARNING

Never exceed the vehicle manufacturer's recommended gross vehicle weight rating (GVWR).

Follow your vehicle's owner's manual for all flat towing steps and limitations.

When operating the tow bar ensure you are in a safe position from vehicle movement and pinch points.

Verify adequate clearances between both vehicles and your towing system in all maneuvering situations.

Always use safety cables when towing. Ensure the safety cables are long enough to allow for turns without becoming entangled with the tow bar or latch handles. Safety or electrical cables becoming entangled with the latch handles could cause one or more arms to collapse, resulting in major damage, injury or death.

Damage may occur if cables come in contact with the ground, tow bar arms or the latch handles. Never wrap cables around tow bar arms. Inspect safety cables prior to towing. Never use damaged safety cables.

Ensure that your towing vehicle is of adequate size to properly control your towed vehicle. Vehicle performance (braking, handling, acceleration, turning radius) can be drastically affected by the towed vehicle. Allow for additional time and space for stopping, changing lanes, passing and turning.

Be sure towing and towed vehicles are aligned with proper tire air pressure. Low air pressure and misaligned vehicles may cause excessive wear, poor vehicle tracking and extra stress on your towing system.

Never back up while flat towing a vehicle. Damage to both vehicles and towing system may occur.

Inspect the tow bar and towing system prior to every use. Check for cracked welds, loose, worn or damaged parts. Do not tow with a damaged or worn tow bar or towing system.

Severe bumps can damage your towing system. Avoid rough terrain and sharp turns.

Never use towed vehicle for storage, this may cause you to exceed the capacity of the tow bar or your towing system.

## Product Photo



## NOTICE

Before you begin installation, read all instructions thoroughly.

Review and follow all state and federal towing laws.

Rear lighting is required on the towed vehicle.

Go to [curtmfg.com](http://curtmfg.com) for RV harnesses and other lighting options.

To help prevent damage to the product or vehicle, refer to the specified torque specifications when securing hardware during the installation process.

# TOW BAR TERMINOLOGY

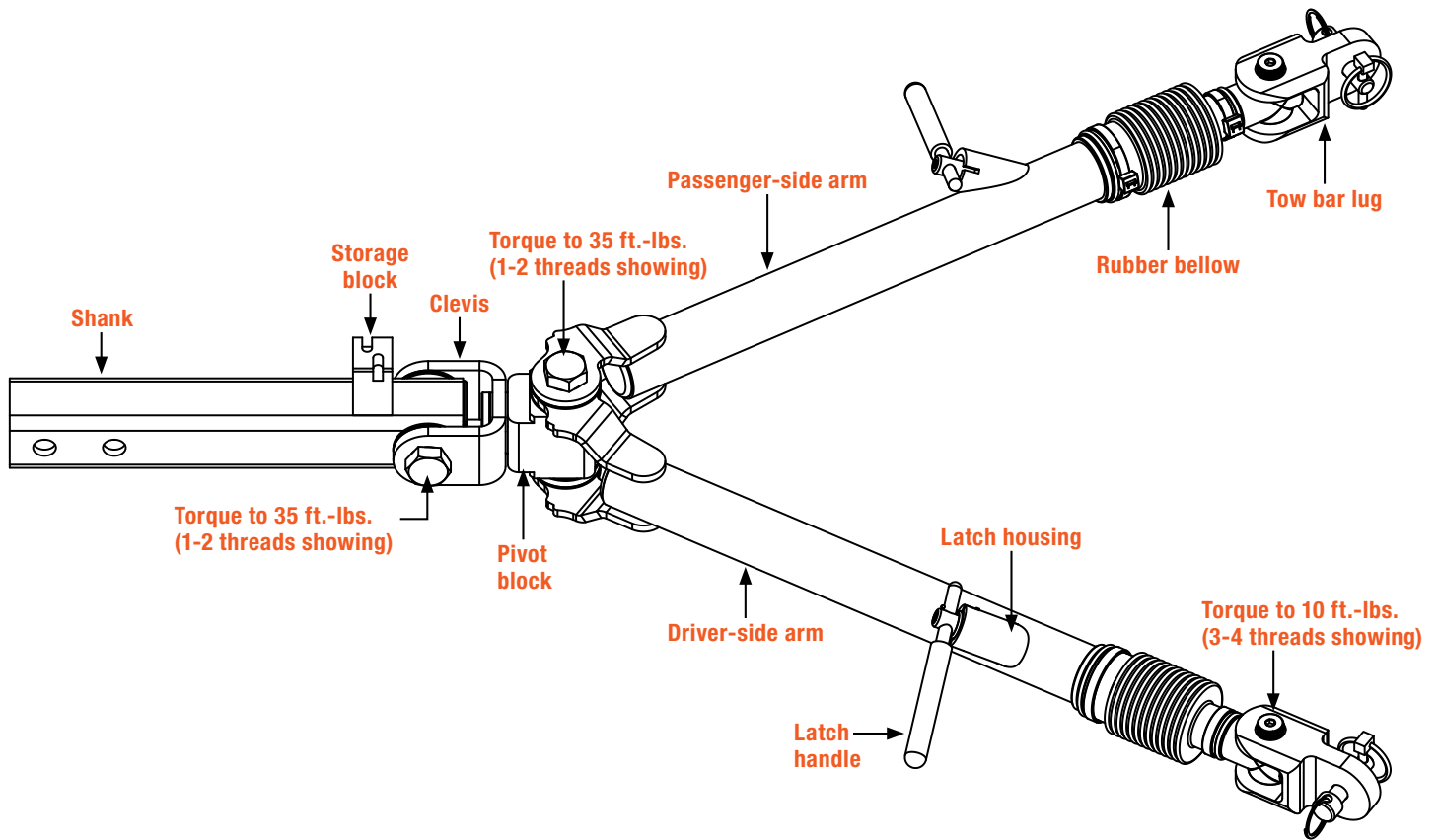

# UNPACKING & INSTALLATION

## Step 1 - Unpacking

Before you begin installation, read all instructions thoroughly. Remove all the parts from packaging and review the parts list to ensure you have all components.

While supporting the tow bar shank pull both arms upward 90° and rotate arms 90°.

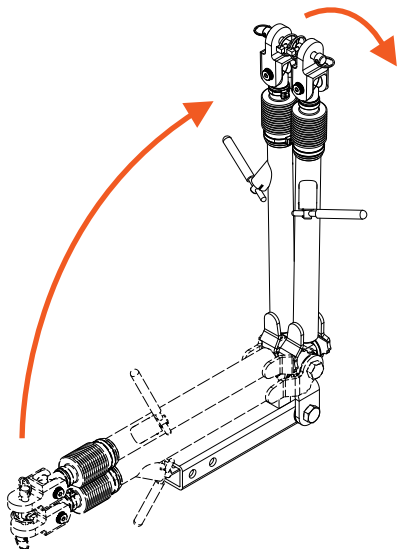

## Step 2 - Installation

Insert the tow bar shank (#1) into the receiver hitch tube of the towing vehicle and secure with the provided pin and clip (#3). **Note:** There are two pin positions on the tow bar shank, it is recommended to use the shortest position when possible.

Rotate the arms out of the storage position into the towing position. Make sure the latch housings are facing upward. **Note:** If necessary, review the 'Storage Positions' on page 6.



# HOOKING UP THE TOWED VEHICLE

## Step 3

The receiver hitch of the **towing** vehicle and the mounting tabs of the **towed** vehicle must be within a 3" height difference above or below. See the diagram below. Go to [curtmfg.com](http://curtmfg.com) for leveling adapters and other tow bar accessories.

Never exceed more than one point of connection between the towing vehicle and the tow bar. Example: Using a leveling adapter between the towing vehicle and tow bar is acceptable. Using a leveling adapter and extension is dangerous and not acceptable.

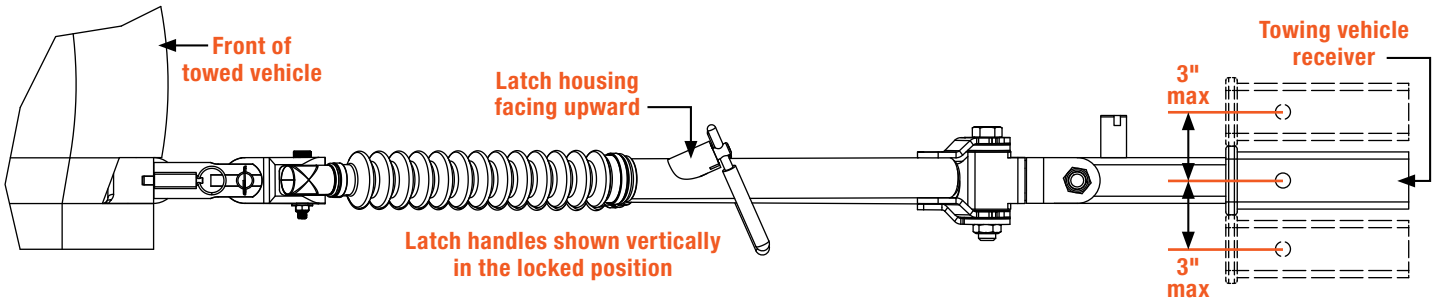

## Step 4

Position the towed vehicle on a level surface squarely behind the towing vehicle in the approximate towing position, this will make hooking up safe and easy.

**IMPORTANT:** Any time you are hooking up or unhooking the tow bar both vehicles should be in park.



## Step 5

While lifting the latch handle, extend each arm to the vehicle tabs. Lifting the latch handle eases moving the arms in and out and aids in maneuvering.

At the end of each arm, position the tow bar lug between the vehicle base plate tab and secure with the provide 1/2" pin and lynch pin.

**IMPORTANT:** Ensure the lynch pin is in the proper orientation and the folding ring closes completely, as shown.

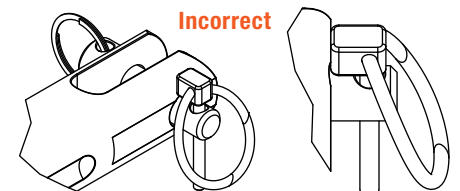
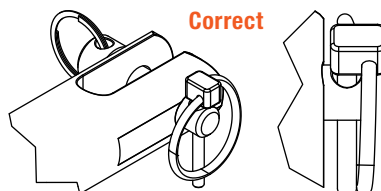
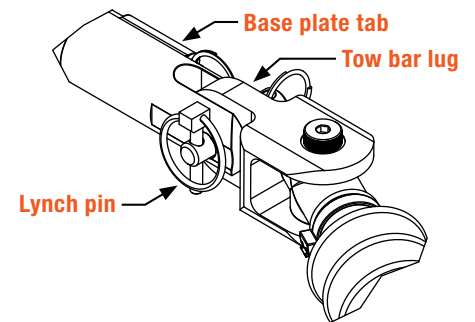

## Step 6

On the towed vehicle, disengage the parking brake, set up the transmission for towing, and unlock the steering wheel.

**Note:** Follow your towed vehicle owner's manual for all steps needed to flat tow your vehicle.

## Step 7

After the towed vehicle is set up for flat towing, pull forward slightly with the towing vehicle until one or both of the locking handles are engaged. Handles will snap down to a vertical position when they are locked.

If only one locking handle is engaged, turn the towing vehicle's steering wheel towards the locked tow bar arm while slowly driving forward.

Always verify both handles are in the locked position prior to towing.

Lift the handle to maneuver the arm and make sliding the arm in and out easier

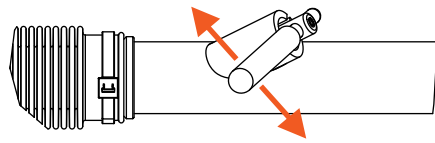

The handle snaps downward when the arm is fully extended to the locked position

Lift the handle to release the arm from the locked position

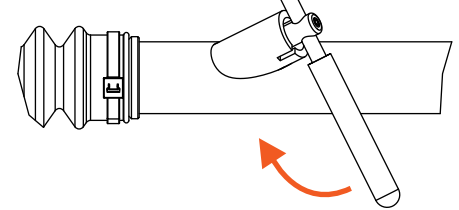

## Step 8

Attach the provided safety cables (#2) to the hitch's safety chain loops / plates or a solid part of the towing vehicle's chassis.

After attaching the cables to the towing vehicle, cross the cables as you run them under the tow bar (#1) toward the towed vehicle. Attach the cables to the base plate convenience links or the solid part of the towed vehicle's chassis.

Verify the cable hooks are fully seated and the safety springs are closed and snapped against the hooks. Safety cables must not be hooked on themselves, kinked or knotted.

This tow bar and safety cable hookup diagram is for reference only. Every towing system is unique and may need to be altered to best fit your setup.

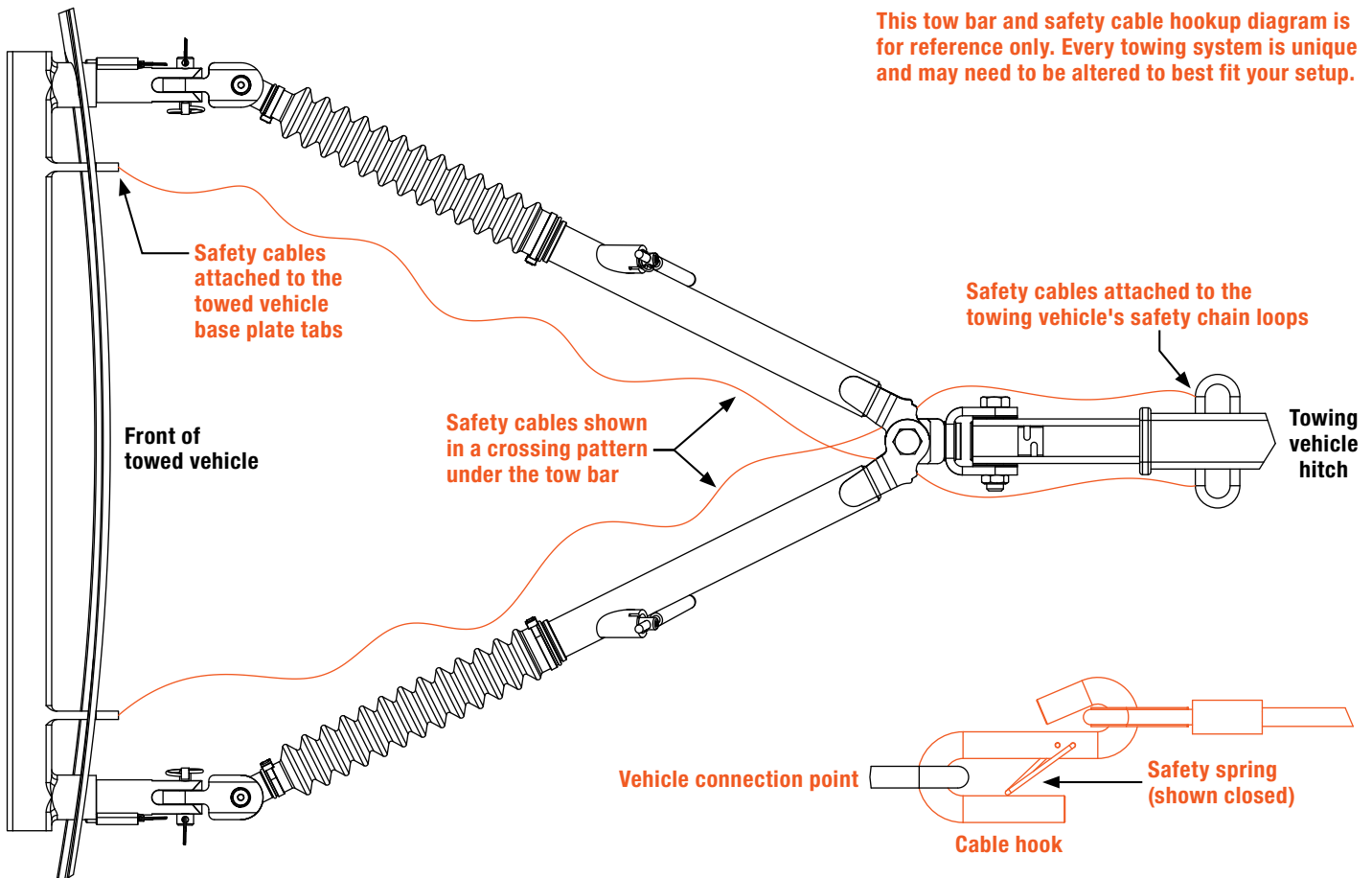

## Step 9

Ensure the safety cables are long enough to allow for turns without making hard contact with the tow bar or latch handles. Damage may occur if the cables come in contact with the ground, tow bar arms or the latch handles. Never wrap the safety cables around the tow bar arms. Inspect the safety cables prior to towing. Never use damaged safety cables. Attach the electrical cable between the towing and towed vehicle.

### **WARNING**

Safety or electrical cables becoming entangled with the latch handles could cause one or more arms to collapse, resulting in major damage, injury or death.

# UNHOOKING THE TOWED VEHICLE

## Step 10

For ease and safety when unhooking the tow bar, park the towing and towed vehicles on a level surface in a straight line.

Unhook the electrical and safety cables.

**IMPORTANT:** Any time you are hooking up or unhooking the tow bar both vehicles should be in park.



## Step 11

Pull up on the arm latches to disengage the arms.

### **CAUTION**

When disengaging the arms, ensure you are in a safe position from vehicle roll and pinch points.

Remove the lynch pins and pull out the 1/2" pins from the tow bar tabs and lugs. While pulling up on the arm latches, retract each arm until it hits an internal hard stop.

Place the 1/2" pins back into the tow bar lugs and secure with the lynch pins, as shown.

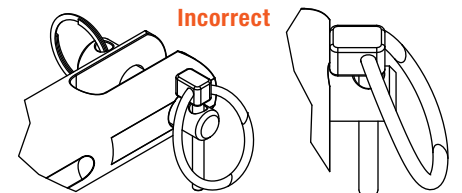
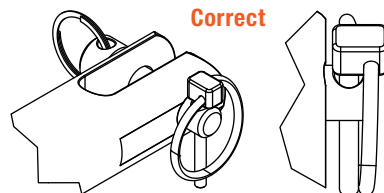

# STORAGE POSITIONS

## Step 1

While holding the tow bar arms horizontal push them inward towards each other.

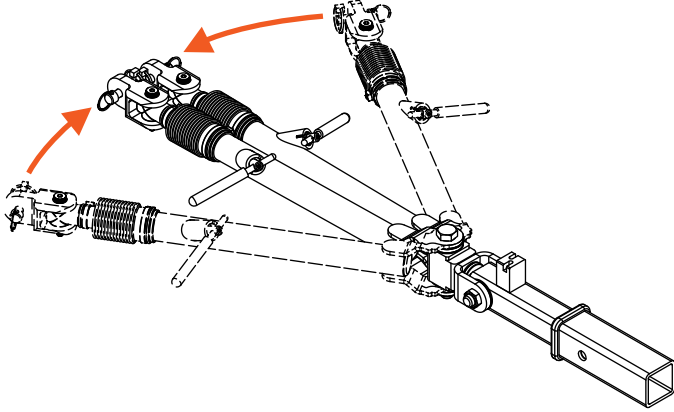

## Step 2

Lift both arms to the vertical position making sure the pivot block is square to the storage block.

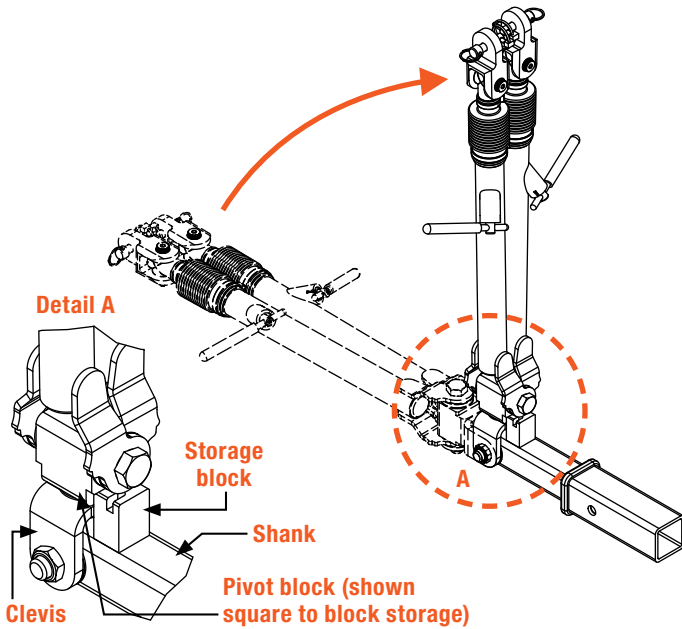

## Step 3 - Storage Options

Lay both arms to the passenger side (1), to the driver side (2) or one arm in each direction (3).

### CAUTION

Check to ensure the arms are fully seated in to the storage block to prevent them from dislodging loose during travel.

