

C-341 SUBKIT

99-06, 07 CLASSIC CHEVY-GMC 1/2 TON, 3/4 TON (LD)
 01-06, 07 CLASSIC CHEVY-GMC 3/4 & 1 TON HD SERIES
 07-08 NEW BODY STYLE CHEVY-GMC 3/4 & 1 TON HD SERIES
 LONG & SHORT BED, SILVERADO & SIERRA SERIES

12/28/2012

30,000 LBS GTW GOOSENECK KIT

INSTALLATION STEPS

REMOVE SPARE TIRE FOR INSTALLATION

WARNING!! BRAKE, FUEL, AND ELECTRICAL LINES MAY NEED TO BE LOOSENED OR REPOSITIONED TO PROVIDE CLEARANCE FOR NEW HARDWARE. ALL MODELS REQUIRE MODIFICATION OR REMOVAL OF HEAT SHIELDS

- 1) Install crossarms by sliding them into gap between the truck bed and frame from inside the wheel well. **As shown in Figure 1.**
- 2) On 2500 & 3500 new body styles, remove electrical box from inside of driver side frame rail by removing two bolts from outside of frame. Hang the side plates from 5/8" studs, which extend from the crossarms. **For all applications**, align the 3/4" hole in the side plate with the existing slot in the frame of the truck. The u-bolt holes should be toward the front of the truck as shown in **Figure 3**. On short bed and 1 ton applications, the center cut-out of the side plate will straddle the truck bed frame rail. Fasten each plate with two 5/8" flange nuts provided. Finger tight only.
- 3) Align the side plate with the existing slot in the frame. Use a 3/4" hex bolt along with a u-bolt to fasten the side plate to the frame rail as shown in **Figure 3**. **ON 2500 & 3500 new body trucks**, attach Curt supplied electrical box bracket to the 3/4" bolt on the inside of frame on driver side as shown in **Figure 3**. Re-attach electrical box to supplied bracket with existing M8 bolts removed earlier from outside of driver side frame. Finger tight 1/2", 3/4" and 5/8" flange nuts only.
- 4) Rotate the crossarms until they contact the truck bed. Use provided tube spacer to achieve the correct distance between the crossarms. Center the rear crossarm studs in the side plate slots as shown in **Figure 2**. Use a 15/16" wrench to tighten the 5/8" flange nuts on the rear crossarm to the side plates. Repeat for both sides. **(Note: Do not tighten crossarms until center section installation is complete.)**
- 5) **Be sure the crossarms are vertical to the truck bed before drilling!** With crossarms secure and evenly spaced, drill a hole through the truck bed at the center of each crossarm mounting hole.
- 6) From inside the truck bed, center the six pilot holes with the letter "A" on the C-52 cutting template. Fasten the template to the truck bed with tape. Once fastened, drill four 1/8" pilot holes through section lettered "B". **(Be sure to check for brake lines and/or fuel lines before drilling.)**
- 7) With the pilot holes drilled, use a sabre saw to cut out section "C". **(Cutting of bed rail supports may be necessary on some models.)**
- 8) Remove template and drill out the six holes with a 21/32" drill bit. Set your C-52 folding hitch ball into place.
- 9) Attach the C-52 to the crossarms using six 5/8" carriage bolts and flange nuts. Torque bolts to 210 lb-ft. **(Note: Spacers must be installed at all bolt locations to prevent truck bed corrugations from collapsing.)**
- 10) After the C-52 has been fastened to the crossarms, torque all 5/8" hardware to 210 lb-ft.
- 11) Torque all 1/2" hardware to 110 lb-ft, and torque all 3/4" hardware to 380 lb-ft.

Parts List			
ITEM	QTY	PART NUMBER	DESCRIPTION
1	4	HFN 1213	HEX FLANGE NUT
2	4	5/8-11	HEX FLANGE NUT
3	2	3 4 FW	FLAT WASHER
4	2	3 4 - 10 HFN	HEX FLANGE NUT
5	2	3 4 - 10 x 2 1/2 HEX	HEX HEAD BOLT-NC
6	2	CM-1201-UBS	1/2-13 x 4 1/8 x 6 3/4 x 1 1/2 SQ U-BOLT
7	2	CM-1202-UBS	1/2-13 x 4 3/4 x 8 3/4 x 2 SQ U-BOLT
8	12	CM-SP27	.188 x 1.00 x 2.00" U-SHAPE SPACER
9	4	CM-SP13	2.50 DIA. x .250" ROUND HOLE SPACER
10	1	CM-TS	.706 DIA. TUBE SPACER
11	1	CM-EBB	11GA. ELECTRICAL BOX BRACKET
12	2	CM-11-CTM	CABLE TIE MOUNT 1 X 1 UV BLACK
13	2	CM-116415-CT	CABLE TIE 11/64 X 15" 50# UV BLACK

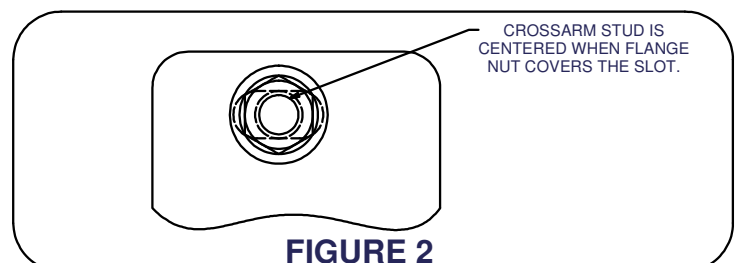
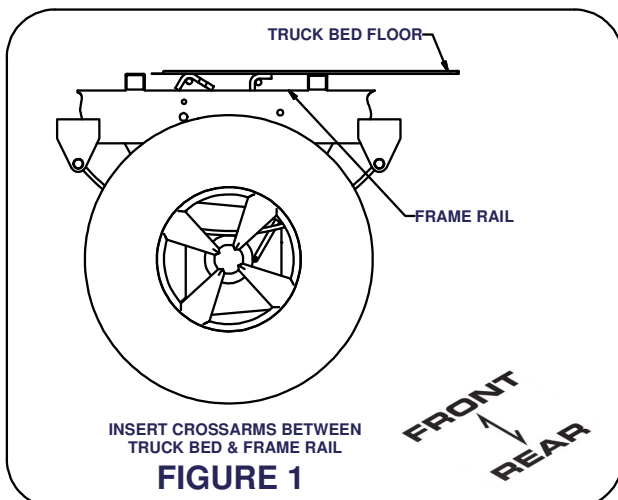

C-341 SUBKIT

99-06, 07 CLASSIC CHEVY-GMC 1/2 TON, 3/4 TON (LD)
 01-06, 07 CLASSIC CHEVY-GMC 3/4 & 1 TON HD SERIES
 07-08 NEW BODY STYLE CHEVY-GMC 3/4 & 1 TON HD SERIES
 LONG & SHORT BED, SILVERADO & SIERRA SERIES

30,000 LBS GTW GOOSENECK KIT

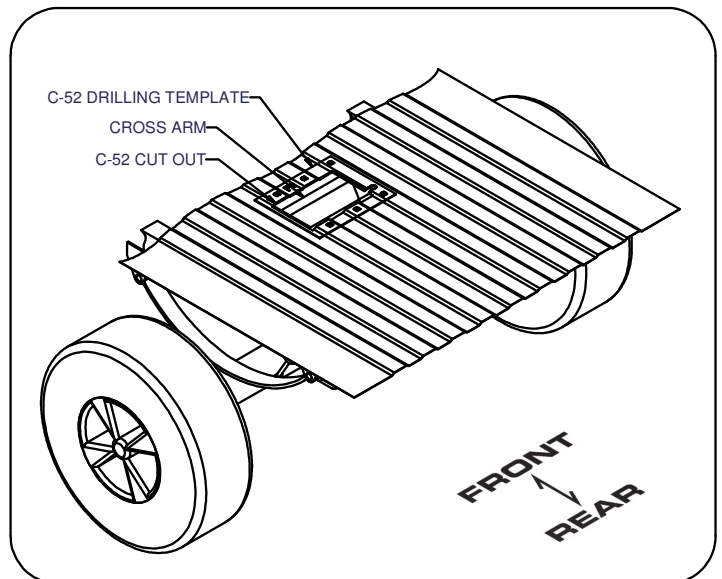
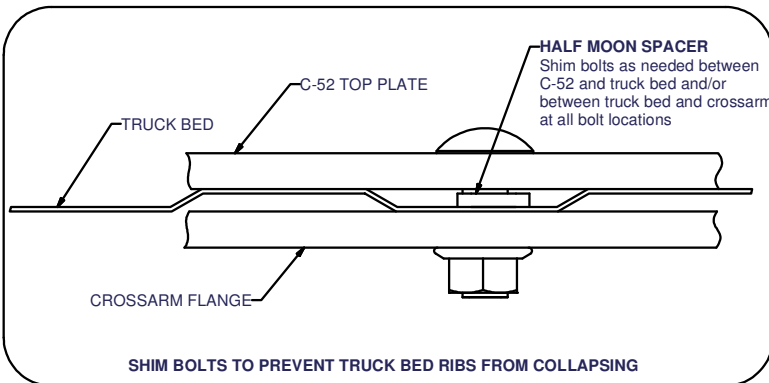
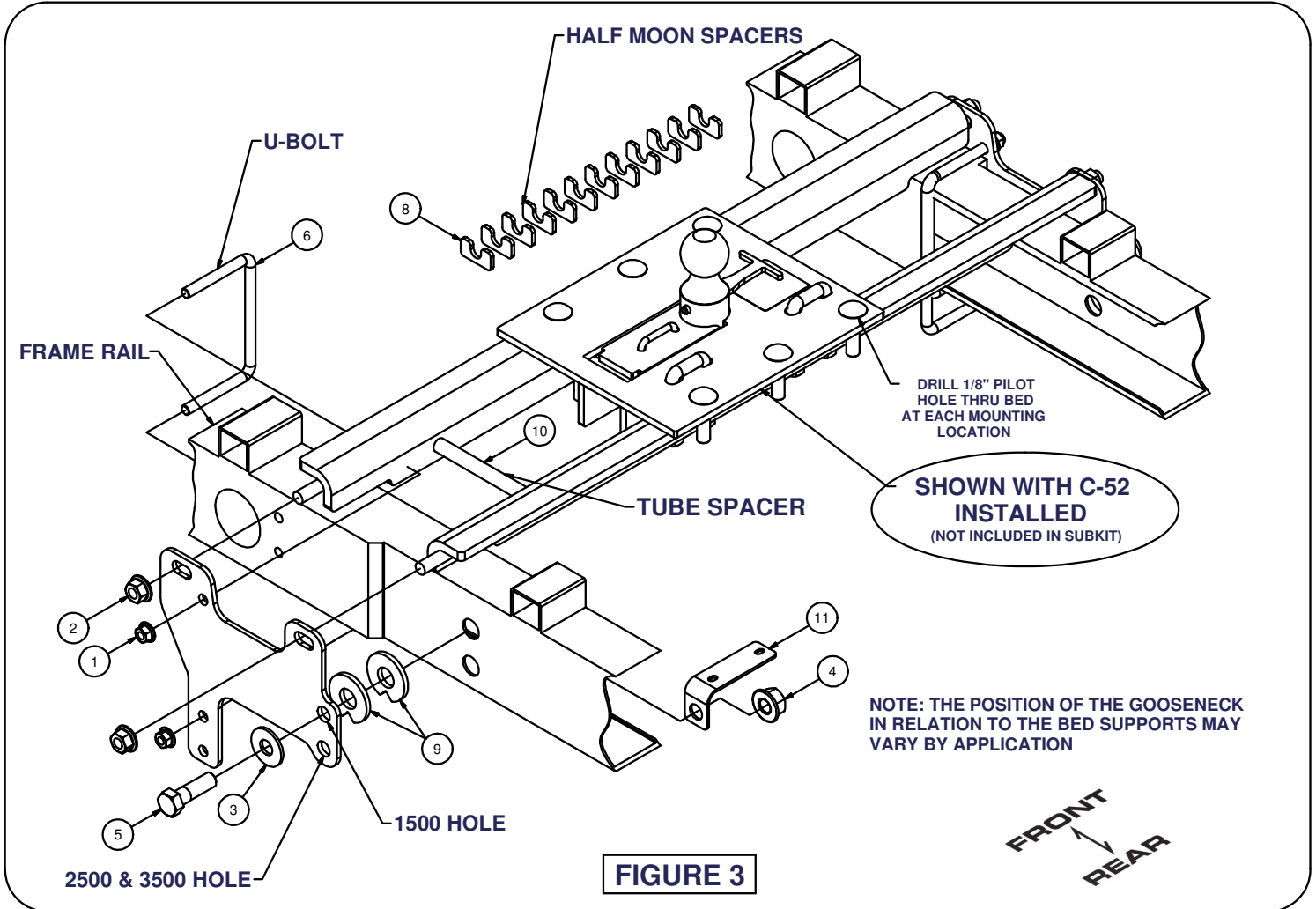

Curt Manufacturing Inc., warrants this product to be free of defects in material or workmanship at the time of retail purchase by the original purchaser. If the product is found to be defective, Curt Manufacturing Inc., may repair or replace the product, at their option, when the product is returned, prepaid, with proof of purchase. Alteration to, misuse of, or improper installation of this product voids the warrant. Curt Manufacturing Inc.'s liability is limited to repair or replacement of products found to be defective, and specifically excludes liability for incidental or consequential loss or damage.

C-34 VACUUM CANISTER RELOCATION

Parts List		
ITEM	PART NUMBER	DESCRIPTION
1	CM-11-CTM	CABLE TIE MOUNT 1 X 1 UV BLACK
2	CM-116415-CT	CABLE TIE 11/64 X 15" 50# UV BLACK

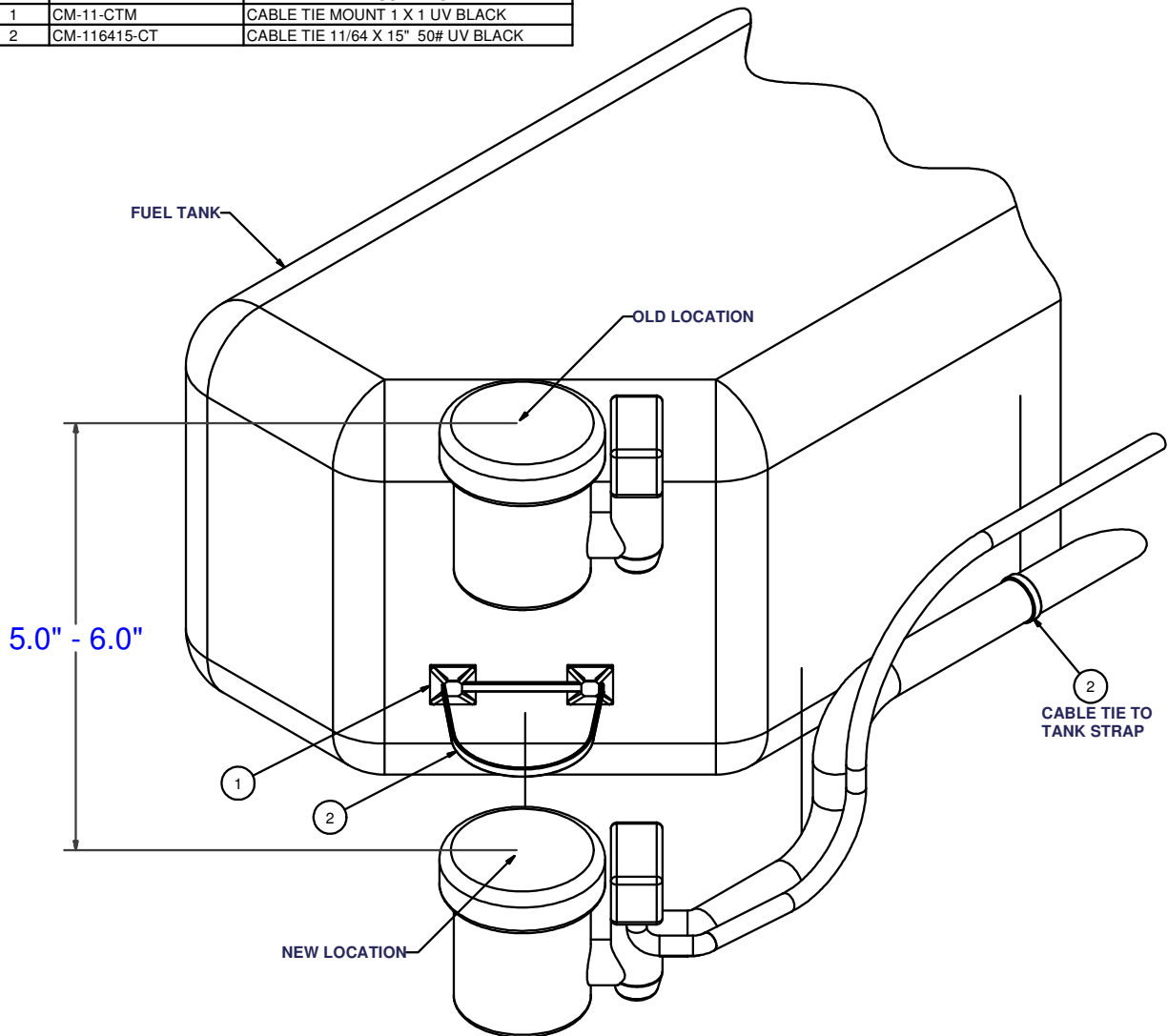

INSTALLATION STEPS

- 1) Remove vacuum canister from OEM mount.
- 2) Clean surface with rubbing alcohol.
- 3) Apply (2) cable tie mounts approximately 3" apart and 5"-6" lower than original location as shown.
- 4) Insert cable tie into mounts, DO NOT FASTEN.
- 5) Position vacuum canister over cable tie and fasten in new location.

PERIODICALLY CHECK THIS RECEIVER HITCH TO ENSURE THAT ALL FASTENERS ARE TIGHT AND THAT ALL STRUCTURAL COMPONENTS ARE SOUND.

Curt Manufacturing Inc., warrants this product to be free of defects in material and/or workmanship at the time of retail purchase by the original purchaser. If the product is found to be defective, Curt Manufacturing Inc., may repair or replace the product, at their option, when the product is returned, prepaid, with proof of purchase. Alteration to, misuse of, or improper installation of this product voids the warranty. Curt Manufacturing Inc.'s liability is limited to repair or replacement of products found to be defective, and specifically excludes liability for incidental or consequential loss or damage.

DO NOT EXCEED VEHICLE MANUFACTURER'S RECOMMENDED TOWING CAPACITY.

CAB TO TRAILER CLEARANCE

REMOVAL OF REAR WINDOW ACCESSORIES MAY BE REQUIRED.

TRAILER

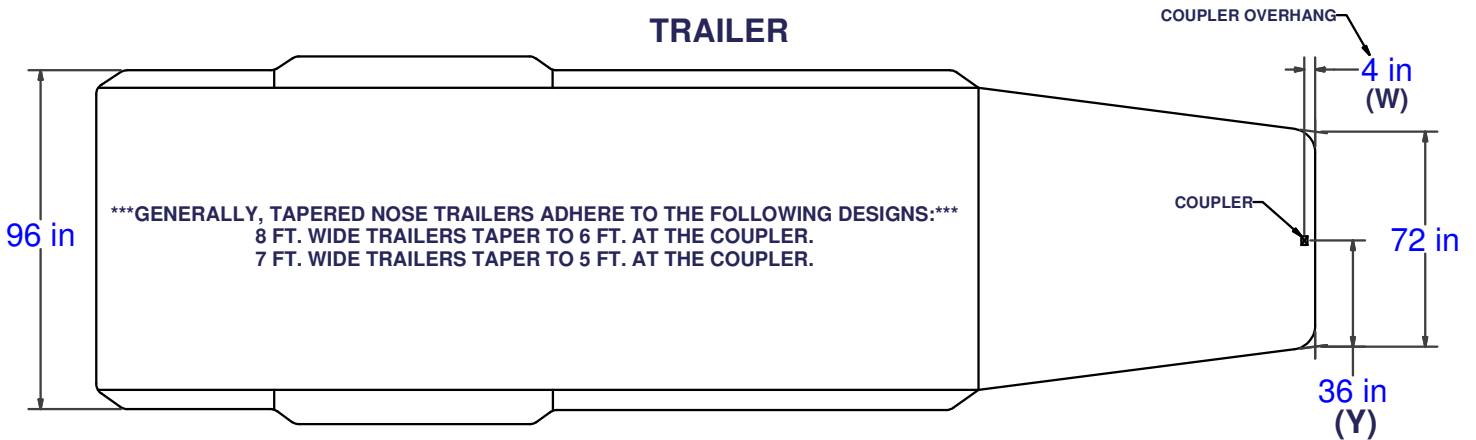

LONG & SHORT TRUCK BEDS

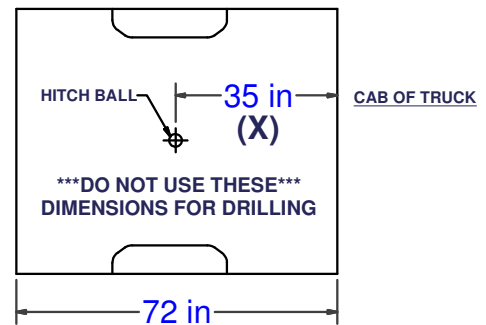
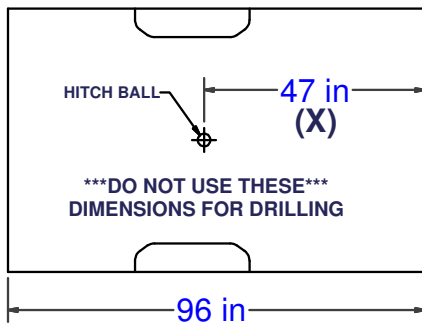

****WARNING REFERENCE CLEARANCE CLACULATOR BEFORE TOWING****

CLEARANCE CALCULATION

$$\begin{matrix} \text{(CAB TO BALL CENTER)} & - & 1/2 \text{ (TRAILER WIDTH)} & = & \text{(MINIMUM CLEARANCE)} \\ \text{(X)} & - & \text{(Y)} & = & \text{(Z)} \end{matrix}$$

IF THERE IS AN OVERHANG FROM THE COUPLER THEN THE EQUATION IS:

$$\text{[(X) - (W)]} - \text{(Y)} = \text{(Z)}$$

IF (Z) IS POSITIVE, TRAILER **WILL NOT** INTERFERE WITH CAB OF TRUCK.
 IF (Z) IS NEGATIVE, TRAILER **WILL** INTERFERE WITH CAB OF TRUCK!!!

EXAMPLE:

STANDARD TRAILER

$$X - Y = Z$$

$$35 - 36 = -1$$

(TRAILER **WILL INTERFERE** WITH CAB)

TRAILER WITH OVERHANG

$$\text{[(X) - (W)]} - Y = Z$$

$$[35 - 4] - 36 = -5$$

(TRAILER **WILL INTERFERE** WITH CAB)

YOUR CALCULATION:

(CAB TO BALL CENTER) _____

(COUPLER OVERHANG) - _____

1/2 (TRAILER WIDTH) - _____

(MINIMUM CLEARANCE) = _____

Curt Manufacturing Inc., warrants this product to be free of defects in material and/or workmanship at the time of retail purchase by the original purchaser. If the product is found to be defective, Curt Manufacturing Inc., may repair or replace the product, at their option, when the product is returned, prepaid, with proof of purchase. Alteration to, misuse of, or improper installation of this product voids the warranty. Curt Manufacturing Inc.'s liability is limited to repair or replacement of products found to be defective, and specifically excludes liability for incidental or consequential loss or damage.