

61301

2011-CURRENT CHEVROLET / GMC 3/4 TON HD AND 1 TON

30,000 LBS GTW GOOSENECK KIT

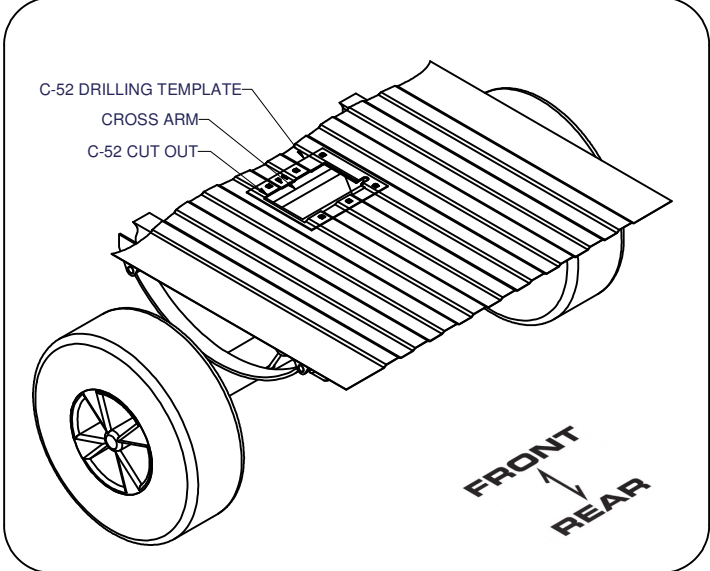
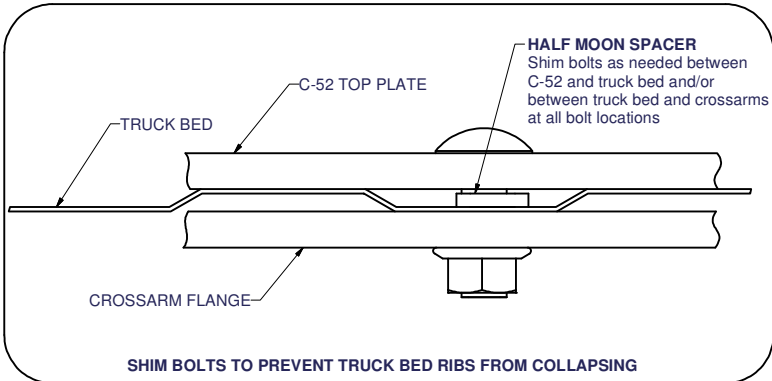
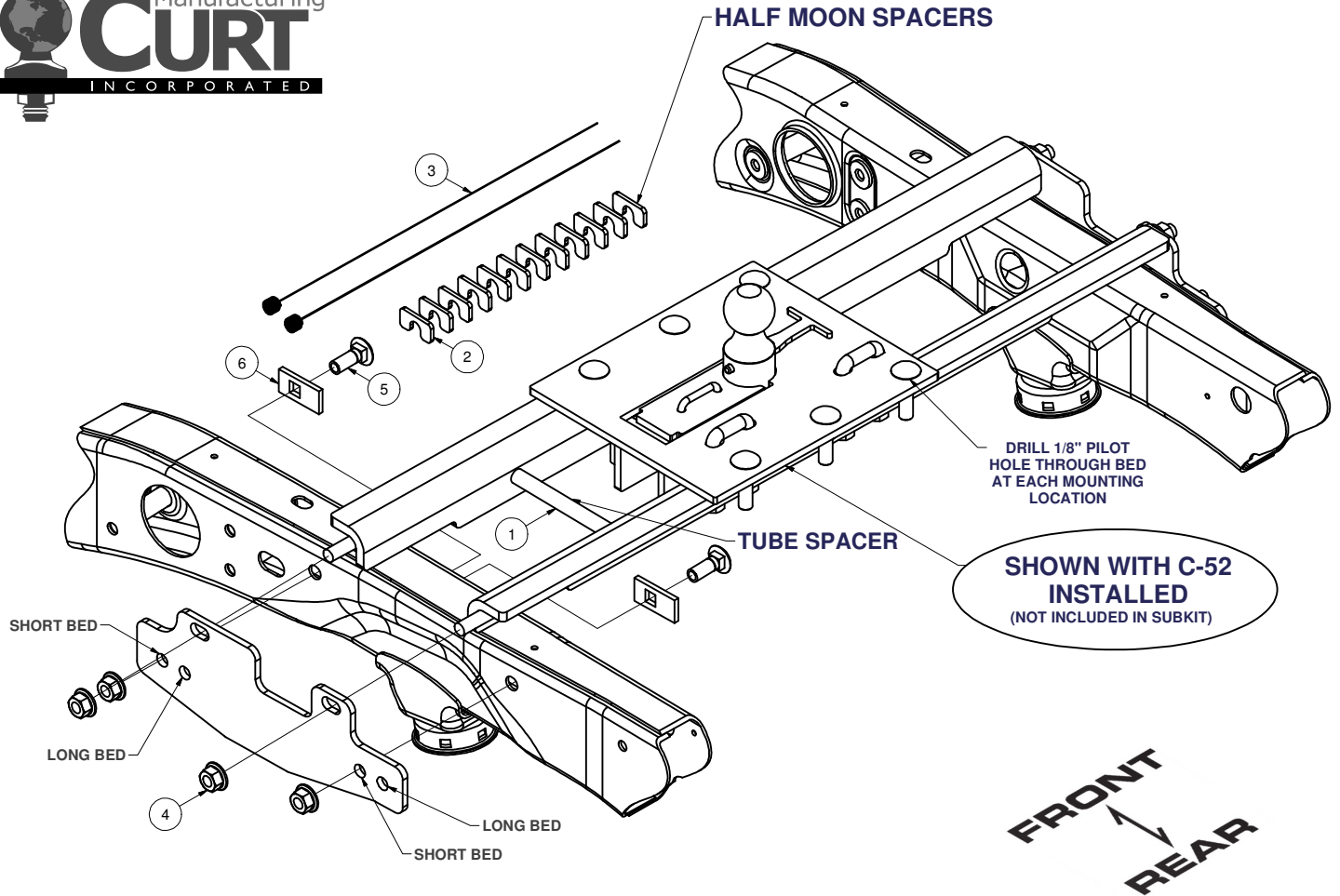

12/26/2012

30,000 LBS GTW GOOSENECK KIT

INSTALLATION STEPS

WARNING!! BRAKE, FUEL, AND ELECTRICAL LINES MAY NEED TO BE LOOSENEED OR REPOSITIONED TO PROVIDE CLEARANCE FOR NEW HARDWARE. ALL MODELS REQUIRE MODIFICATION OR REMOVAL OF HEAT SHIELDS

1. Remove spare tire for ease of installation.
2. Trim out heat shields between the bed supports on the passenger side of the vehicle.
3. Install cross arms by sliding them into gap between the truck bed and frame from inside the wheel well. The lip extending below the truck bed will need to be cut to allow the cross arms to slide into position as shown in diagram below. The front cross arm is 42 1/4" long and the rear cross arm is 41 11/16" long.
4. Align the side plates with the existing holes in the frame rails. Long and short bed vehicles will use different sets of holes. Fishwire 5/8" carriage bolts and CM-SP9 spacers through inside of frame rail and out mounting holes. Secure side plates with 5/8" hex flange nuts.
5. Rotate the cross arms until they contact the truck bed. Use provided tube spacer to achieve the correct distance between the cross arms. Center the threaded crossarm studs in the side plate slots as shown. Secure the cross arms with 5/8" hex flange nuts. **(Note: Do not tighten cross arms until center section installation is complete.)**
6. **Be sure the cross arms are vertical to the truck bed before drilling!** With cross arms secure and evenly spaced, drill a hole through the truck bed at the center of each cross arm mounting hole.
7. From inside the truck bed, center the six pilot holes with the letter "A" on the C-52 cutting template. Fasten the template to the truck bed with tape. Once fastened, drill four 1/8" pilot holes through section lettered "B". **(Be sure to check for brake lines and/or fuel lines before drilling.)**
8. With the pilot holes drilled, use a saw to cut out section "C". **(Cutting of bed rail supports may be necessary on some models.)**
9. Remove template and drill out the six holes with a 21/32" drill bit. Set the C-52 gooseneck (sold separately) hitch into position.
10. Attach the C-52 to the cross arms using (6) 5/8" carriage bolts and flange nuts. Torque bolts to 210 lb-ft. **(Note: Spacers must be installed at all bolt locations to prevent truck bed corrugations from collapsing.)**
11. After the C-52 has been fastened to the cross arms, torque 5/8" hardware connecting the cross arms to the side plates to 210 lb-ft.
12. Torque 5/8" hardware connecting side plates to vehicle frame to 210 lb-ft to finish installation.

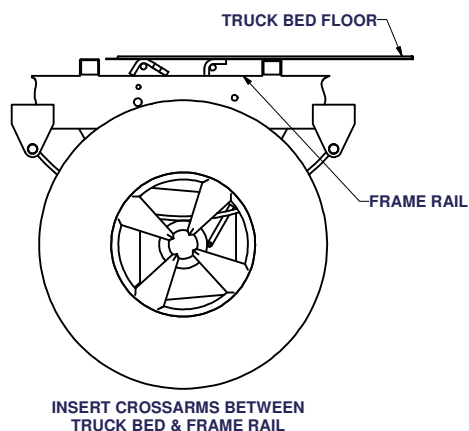
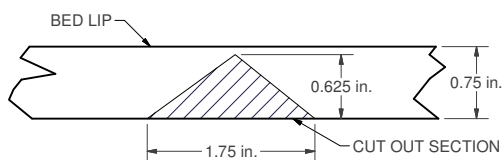

Parts List			
ITEM	QTY	PART NUMBER	DESCRIPTION
1	1	CM-TS	.706 DIA.TUBE SPACER
2	12	CM-SP27	.188 x 1.00 x 2.00" U-SHAPE SPACER
3	2	5 8 FISHWIRE	5/8" FISHWIRE
4	8	5/8-11	HEX FLANGE NUT
5	4	5/8-11 x 1 3/4	CARRIAGE BOLT
6	4	CM-SP9	.250 x 1.25 x 2.50" SQUARE HOLE SPACER

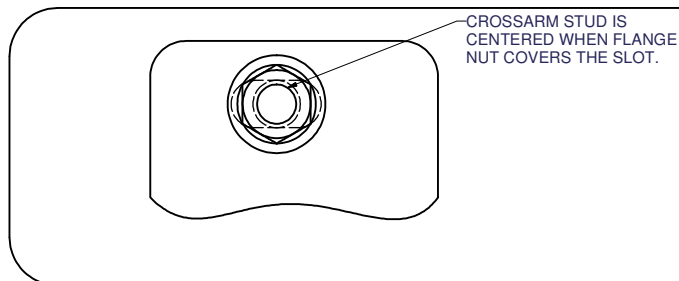

DO NOT EXCEED VEHICLE MANUFACTURER'S RECOMMENDED TOWING CAPACITY.

CAB TO TRAILER CLEARANCE

REMOVAL OF REAR WINDOW ACCESSORIES MAY BE REQUIRED.

TRAILER

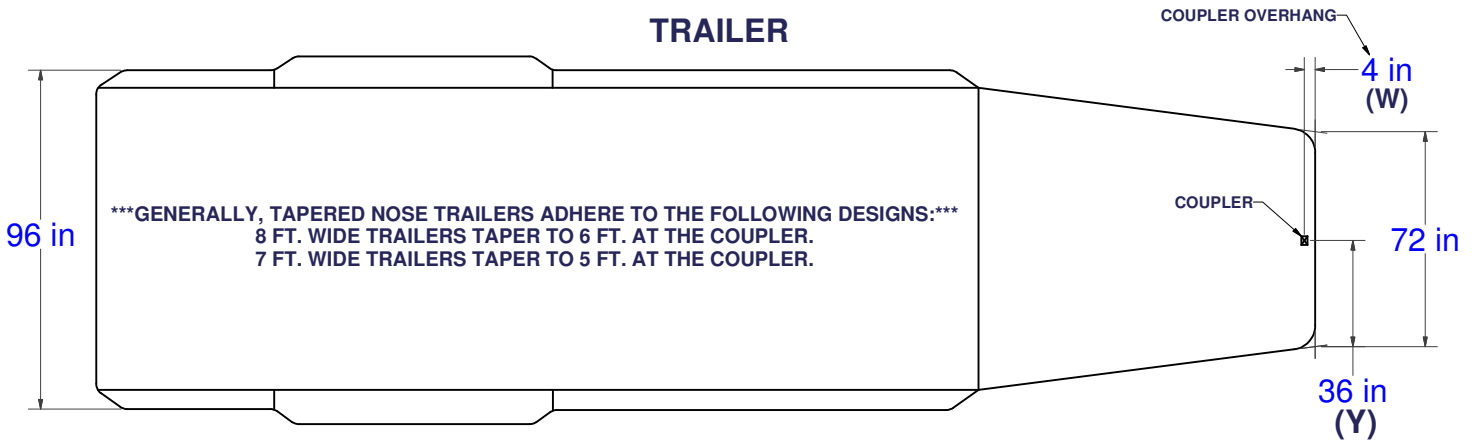

LONG & SHORT TRUCK BEDS

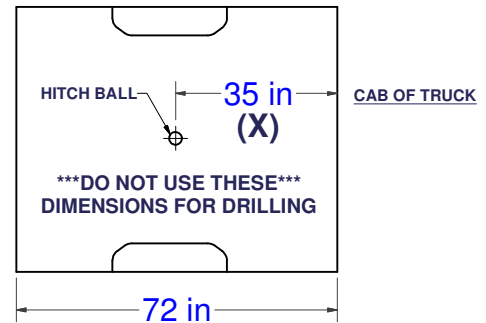
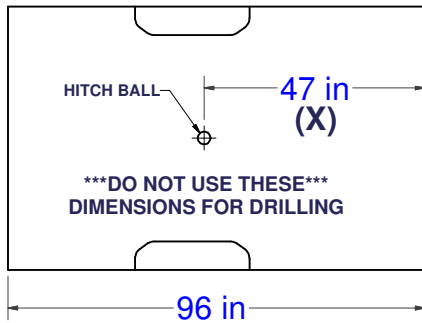

****WARNING REFERENCE CLEARANCE CLACULATOR BEFORE TOWING****

CLEARANCE CALCULATION

$$\begin{matrix} \text{(CAB TO BALL CENTER)} & - & 1/2 \text{ (TRAILER WIDTH)} & = & \text{(MINIMUM CLEARANCE)} \\ \text{(X)} & - & \text{(Y)} & = & \text{(Z)} \end{matrix}$$

IF THERE IS AN OVERHANG FROM THE COUPLER THEN THE EQUATION IS:

$$\text{[(X) - (W)]} - \text{(Y)} = \text{(Z)}$$

IF (Z) IS POSITIVE, TRAILER **WILL NOT** INTERFERE WITH CAB OF TRUCK.
 IF (Z) IS NEGATIVE, TRAILER **WILL** INTERFERE WITH CAB OF TRUCK!!!

EXAMPLE:

STANDARD TRAILER

$$X - Y = Z$$

$$35 - 36 = -1$$

(TRAILER **WILL INTERFERE** WITH CAB)

TRAILER WITH OVERHANG

$$\text{[(X) - (W)]} - Y = Z$$

$$[35 - 4] - 36 = -5$$

(TRAILER **WILL INTERFERE** WITH CAB)

YOUR CALCULATION:

(CAB TO BALL CENTER) _____

(COUPLER OVERHANG) - _____

1/2 (TRAILER WIDTH) - _____

(MINIMUM CLEARANCE) = _____