



CURTTM

The **FIRST** Name
in Towing ProductsTM

DOUBLE LOCK GOOSENECK

INSTRUCTION MANUAL



Installer: Read and understand this manual. Fully instruct and demonstrate the operation of this gooseneck hitch to the end user. Include the importance of observing all warnings. Provide this manual in its entirety to the end-user.

60607

GOOSENECK HITCH

2/26/2013

Parts List			
ITEM	QTY	PART NUMBER	DESCRIPTION
1	2	CM-C60-CLA	SAFETY CHAIN LOOP ASSEMBLY
1.1	1	CM-C60-CL	2" x 3" SAFETY CHAIN LOOP
1.2	2	CM-C60-S	U-BOLT SPRING
1.3	2	1_2 - 13	NYLOCK HEX NUT
1.4	4	FW12SAE	FW, 1/2 SAE, ZP
2	2	3/8"	WASHER
3	3	#10-32 x 3/4	FLAT HEAD C'SUNK CAP SCREW
4	1	#10-24 NYLOCK HEX NUT	NYLOCK HEX NUT
5	1	#10-24 x 1.25 HHFS	HEX HEAD FLANGE SCREW
6	1	CM-C60-B	TURNOVER BALL COMPLETE
7	1	CM-C600-CLP	CAST LOCK PIN
8	1	CM-C60-R	.375" HANDLE ROD
9	1	CM-C60-CS	7.5 LB COMPRESSION SPRING
10	1	CM-C60-H	VINYL HANDLE GRIP
11	1	CM-C60-RC	RUBBER COVER
12	1	CM-UE1	.300" U-SHAPED EDGING
13	1	CM-C600-CR	3.75 DIA. x .375" CHROME RING

WARNING DO NOT invert ball when carrying heavy loads on 2 wheel drive trucks. The ball may hit the top of the differential, brake lines, or sensors.
(NOTE: Do not invert ball on any Toyota Tundra Models)

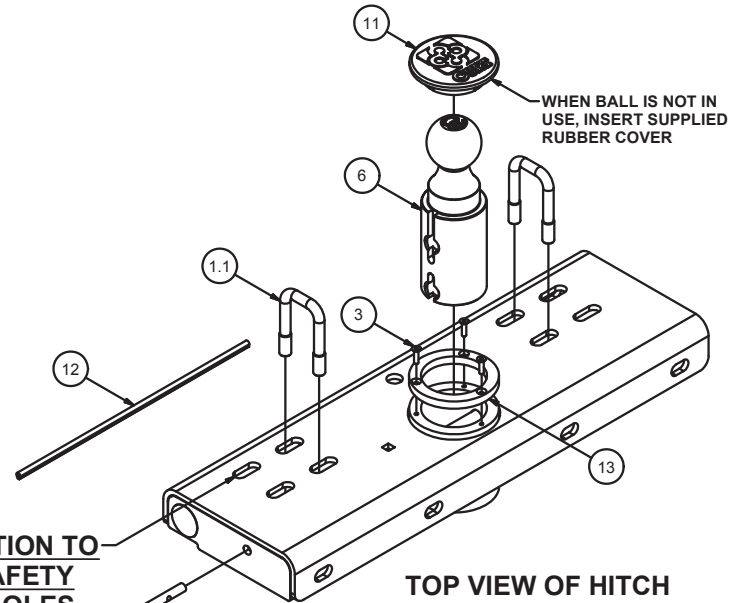

USE 60607 CENTER SECTION TO LOCATE AND DRILL SAFETY CHAIN ATTACHMENT HOLES

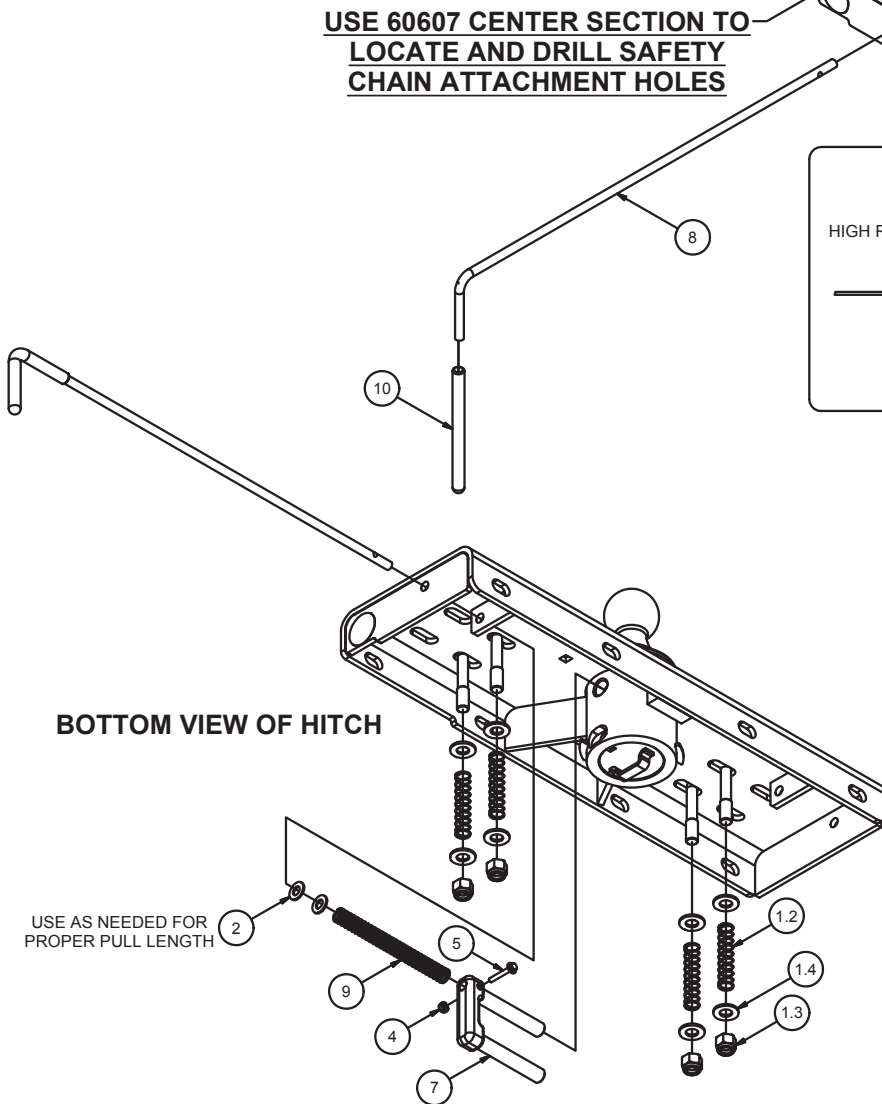
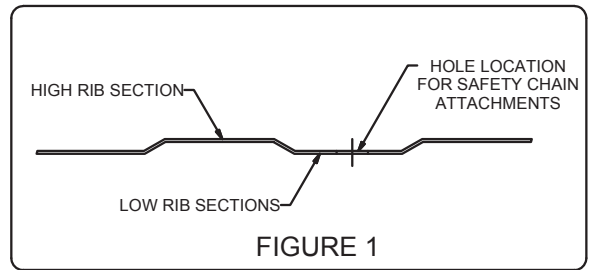

U-EDGING INSTALLED AROUND EDGE OF 4" HOLE IN TRUCK BED

Curt Manufacturing LLC., warrants this product to be free of defects in material and/or workmanship at the time of retail purchase by the original purchaser. If the product is found to be defective, Curt Manufacturing LLC., may repair or replace the product, at their option, when the product is returned, prepaid, with proof of purchase. Alteration to, misuse of, or improper installation of this product voids the warranty. Curt Manufacturing LLC.'s liability is limited to repair or replacement of products found to be defective, and specifically excludes liability for incidental or consequential loss or damage.

Warning!! Carefully examine the location of fuel lines, brake lines, and electrical wires BEFORE INSTALLATION. Brake, fuel, and electrical lines may need to be loosened or repositioned to provide clearance for new hardware. The installation of this hitch may require modification or removal of heat shields. The use of overload springs, air bags, etc. may be required when towing heavy loads.

Installing 60607 Turnover Gooseneck After Cross Arm Sub-kit Installation

- 1) Install rubber edging (CM-UE1) on cut edge for 60607 cylinder, trim excess.
- 2) Position the 60607 over the rear axle and up to the rear cross arm with the cylinder facing the correct direction for the application. Install four 1/2" x 1 3/4" carriage bolts into the 60607 first, then through the rear cross arm and secure with 1/2" flange nuts, finger tighten.
- 3) Move the front cross arm to the 60607 and install the 1/2" x 1 3/4" carriage bolts into the cross arm then through the 60607 and secure with 1/2" flange nuts.
- 4) Torque all 1/2" hardware to 110 ft-lbs.

Installing Safety Chain Attachments

- 1) From under the truck use the 60607 gooseneck as a template to drill four 1/2" holes for the safety chain attachments.
- 2) Using a 1/2" drill bit, drill the center of each slotted hole in the gooseneck. (**Note: Be sure the holes are drilled in the lower rib section of the truck bed as shown in FIGURE 1**).
- 3) From inside the truck box place the two U-bolts (1.1) through the predrilled holes in the bed of the truck.
- 4) From beneath the truck place a washer (1.4), a spring (1.2), a washer (1.4) and a nylock nut (1.3) on each of the four U-bolt legs. Tighten the nylock nuts until flush with the bottom of the U-bolt.

Installing handle / lock

- 1) Insert Locking Pin (7) into the ball cylinder with handle rod hole located on top.
- 2) Slide rubber grip (10) onto handle rod.
- 3) Insert handle rod from outside vehicle, through the hole in the 60607 endplate, and through the rod guide as shown. (Handle rod may be installed on driver side or passenger side, depending on preference).
- 4) Slide the compression spring (9) over handle rod before inserting the handle rod into the locking pin. Insert handle rod into locking pin and secure with #10 screw (5) and nylock nut (4) as shown.
(**Note: Use 1-2 additional 3/8" washers (2) as needed to ensure proper pull length of locking pin**).

Caution!!!

1. Check that all 1/2" hardware has been torqued to 110 ft-lbs.
2. Check that all side plate hardware has been torqued. Some hardware listed will not apply to your application.
 - 3/8" to 45 ft-lbs.
 - 1/2" to 110 ft-lbs.
 - 9/16" to 150 ft-lbs.
 - 5/8" to 210 ft-lbs.
 - 3/4" to 380 ft-lbs.
3. Re-attach Brake, Fuel, and Electrical lines so they do not contact any of the added fasteners.

60607 Operation

1. Pull the handle out as far as possible and rotate clockwise until the locking pin is disengaged and locked out.
2. Insert ball in the tow position into the cylinder by aligning the ball groove with the cylinder pin. If the groove and pin are not aligned simply rotate ball until the ball drops into place.
3. Rotate handle counter clockwise until locking pin snaps back into position. (Note: Be certain the locking pin passes completely through the ball and securely into the cylinder).

60607 Installation check

1. Set ball in towing position and handle in locked position.
2. Connect the trailer to the hitch ball.
3. Check truck box clearance, there should be a minimum clearance of 6" between the bottom of the trailer overhang and the top of the box sides. Verify clearance between the truck and trailer at cab and box corners.

Maintenance (Required every 30 days or prior to use)

1. Keep hitch ball lubricated regularly. Use silicone spray or equivalent to prevent wear and rust.
2. Keep hitch assembly free of dirt and other foreign debris.
3. Check for proper torque on all nuts and bolts before each use. Also check for excessive wear.
4. Check for ball wear before each use. (**Note: Do not tow trailer with worn or damaged parts**).

DO NOT EXCEED VEHICLE MANUFACTURER'S RECOMMENDED TOWING CAPACITY.

CAB TO TRAILER CLEARANCE

REMOVAL OF REAR WINDOW ACCESSORIES MAY BE REQUIRED.

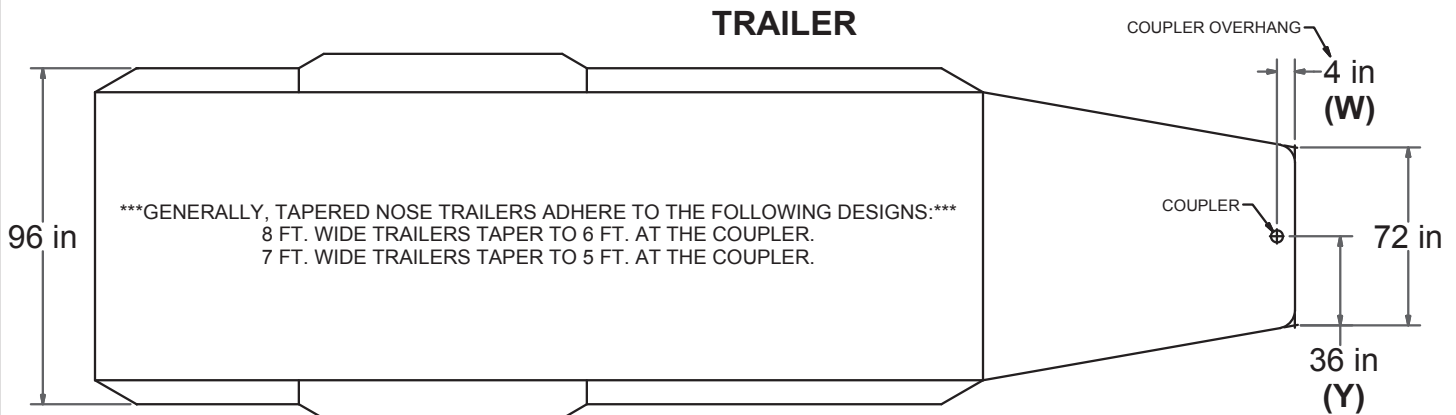

LONG & SHORT TRUCK BEDS

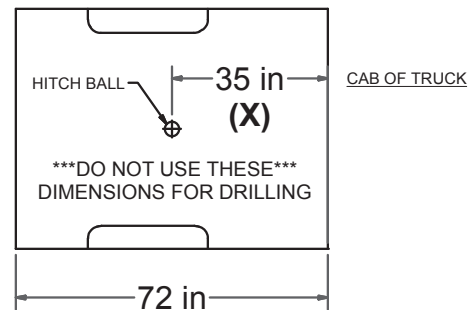
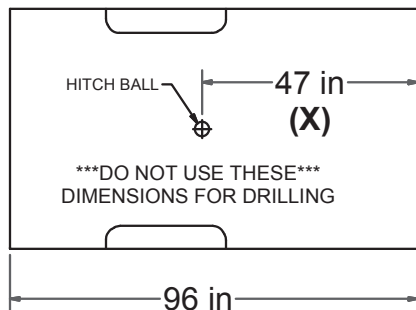

WARNING REFERENCE CLEARANCE CALCULATOR BEFORE TOWING

CLEARANCE CALCULATION

$$\begin{matrix} \text{(CAB TO BALL CENTER)} & - & 1/2 \text{ (TRAILER WIDTH)} & = & \text{(MINIMUM CLEARANCE)} \\ \text{(X)} & - & \text{(Y)} & = & \text{(Z)} \end{matrix}$$

IF THERE IS AN OVERHANG FROM THE COUPLER THEN THE EQUATION IS:

$$[(X) - (W)] - (Y) = (Z)$$

IF (Z) IS POSITIVE, TRAILER **WILL NOT** INTERFERE WITH CAB OF TRUCK.
 IF (Z) IS NEGATIVE, TRAILER **WILL** INTERFERE WITH CAB OF TRUCK!!!

EXAMPLE:

STANDARD TRAILER

$$X - Y = Z$$

$$35 - 36 = -1$$

(TRAILER **WILL INTERFERE** WITH CAB)

TRAILER WITH OVERHANG

$$[(X) - (W)] - Y = Z$$

$$[35 - 4] - 36 = -5$$

(TRAILER **WILL INTERFERE** WITH CAB)

YOUR CALCULATION:

(CAB TO BALL CENTER) _____

- _____

(COUPLER OVERHANG) _____

- _____

1/2 (TRAILER WIDTH) _____

= _____

(MINIMUM CLEARANCE) _____

Curt Manufacturing LLC., warrants this product to be free of defects in material and/or workmanship at the time of retail purchase by the original purchaser. If the product is found to be defective, Curt Manufacturing LLC., may repair or replace the product, at their option, when the product is returned, prepaid, with proof of purchase. Alteration to, misuse of, or improper installation of this product voids the warranty. Curt Manufacturing LLC.'s liability is limited to repair or replacement of products found to be defective, and specifically excludes liability for incidental or consequential loss or damage.

Looking for trailer hitches & towing? Visit our website.