

****DO NOT EXCEED RECOMMENDED VEHICLE TOWING WEIGHT!****

60701 SUBKIT

CHEVY & GMC 2500 / 3500



12/10/2020

PAGE 1 OF 4

WARNING!! BRAKE, FUEL, AND ELECTRICAL LINES MAY NEED TO BE LOOSENED OR REPOSITIONED TO PROVIDE CLEARANCE FOR NEW HARDWARE. ALL MODELS REQUIRE MODIFICATION OR REMOVAL OF HEAT SHIELDS. ON SHORT BED MODELS, CHECK FOR ADEQUATE TURNING CLEARANCE BETWEEN THE FRONT OF ALL TRAILERS AND THE TRUCK CAB. ON TWO WHEEL DRIVE TRUCKS A CLEARANCE CHECK MUST BE PERFORMED WHEN TRUCK IS LOADED AND UNLOADED TO VERIFY THE INVERTED BALL WILL NOT INTERFERE WITH THE TOP OF THE DIFFERENTIAL



Parts List			
ITEM	QTY	PART NUMBER	DESCRIPTION
1	2	CM-SP9	.375 x 1.25 x 2.50" SQUARE HOLE SPACER
2	2	CM-1215-UBS	1/2-13 x 5 1/4 x 6 x 1 1/2 SQ U-BOLT
3	8	10-10038	HHCS, 5/8-11 UNC, 1-1/2, GRD8
4	2	10-10292	BOLT, CAR, 5/8-11 UNC, 1-3/4, GRD8, YZ
5	8	10-10334	HHCS, 1/2-13 UNC, 1-1/2, GRD8, YZ
6	4	20-00062	NUT, SER-FLANGE, 1/2-13 UNC, GRD8, YZ
7	6	20-00105	NUT, SER-FLANGE, 5/8-11 UNC, GRD8, YZ
8	8	30-00149	WASHER, S-CON, 1/2, YZ
9	8	30-00131	WASHER, FLAT, 5/8
10	4	30-00204	WASHER, FLAT, 5/8, YZ
11	4	10-10296	HHCS, 5/8-11 UNC, 1-3/4, GRD8
12	2	5_8 FISHWIRE	5/8" FISHWIRE

Parts List			
ITEM	QTY	PART NUMBER	DESCRIPTION
A	1	60701-DS	DRIVER SIDE PLATE
B	1	60701-PS	PASSENGER SIDE PLATE
C	1	60701-RCA	REAR CROSS ARM (47.00")
D	1	60701-FCA	FRONT CROSS ARM (47.25")
E	2	60701-BR	BRACKET
F	2	60701-MP	MOUNTING PLATE

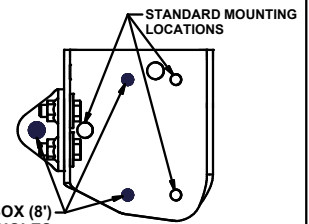

LONG BOX (8") MOUNTING HOLES
MOUNTING LOCATIONS

DESIGNED FOR USE WITH 60611 CENTER SECTION (NOT INCLUDED IN SUBKIT)

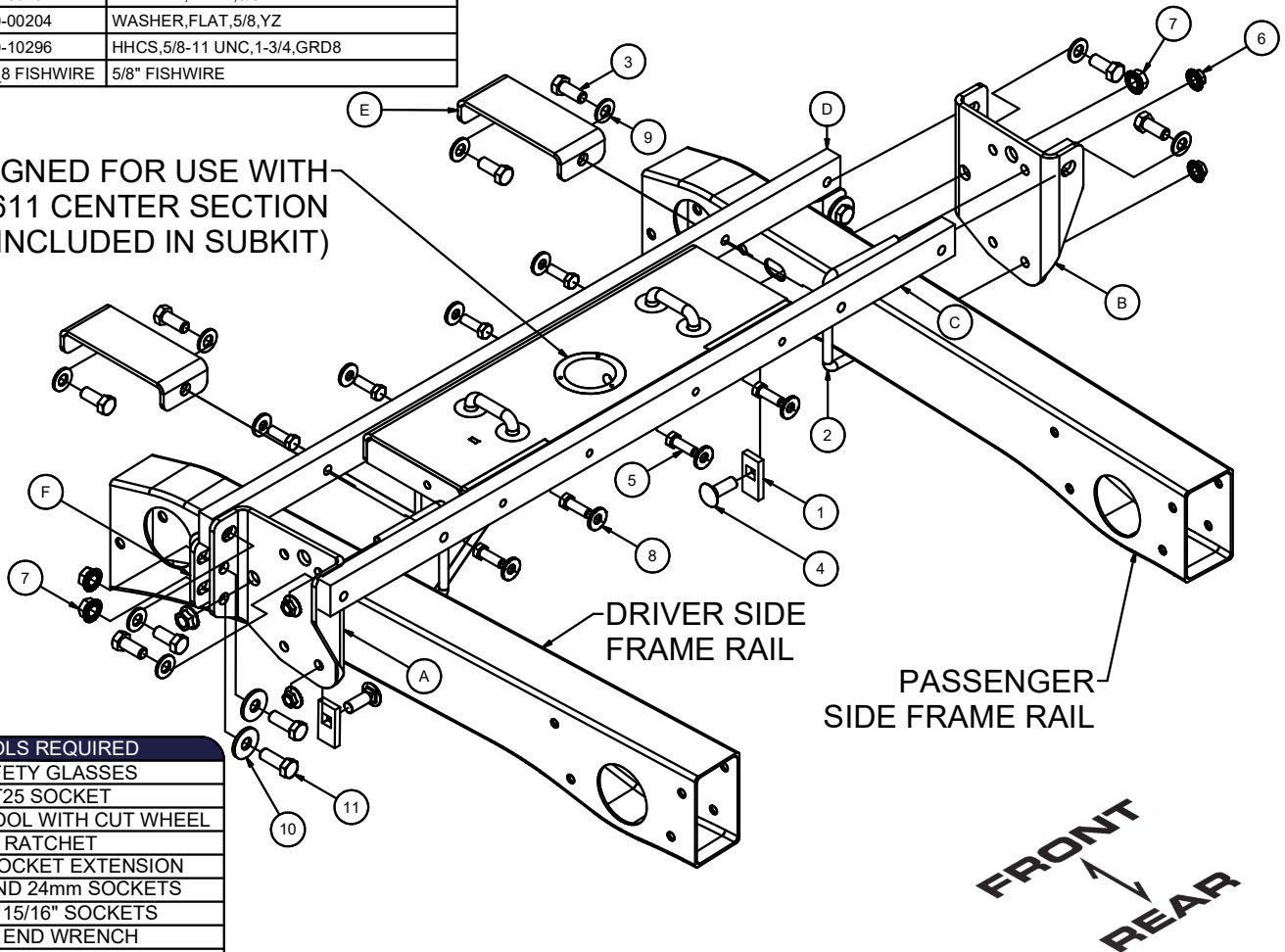

TOOLS REQUIRED	
SAFETY GLASSES	
T25 SOCKET	
ROTARY TOOL WITH CUT WHEEL	
RATCHET	
3" & 6" SOCKET EXTENSION	
13, 18 AND 24mm SOCKETS	
3/4" & 15/16" SOCKETS	
3/4" END WRENCH	
ADJUSTABLE WRENCH	
TORQUE WRENCH	



SUBKIT WEIGHT: 66 LBS.
INSTALL TIME
 PROFESSIONAL: 45 MINUTES
 NOVICE (DIY): 90 MINUTES
INSTALL NOTES:
 - LOWER SPARE TIRE
 - TRIM HEAT SHIELD
 - NO MEASURING DRILL LOCATIONS
 - NO DRILLING INTO FRAME
 - NO LOWERING EXHAUST

FISHWIRE TECHNIQUE

INSERT COILED END OF FISHWIRE TOOL THROUGH HITCH MOUNTING HOLE IN VEHICLE FRAME RAIL AND OUT THE ACCESS HOLE. PASS COILED END OF FISHWIRE THROUGH SPACER AND THREAD BOLT INTO COIL. KINK WIRE TO KEEP SPACER SEPERATE FROM BOLT AS SHOWN. PULL FISHWIRE, SPACER, AND BOLT THROUGH FRAME AND OUT MOUNTING HOLE. USE FISHWIRE TO GUIDE HITCH DURING MOUNTING AND PREVENT LOSS OF BOLT / SPACER INSIDE FRAME RAIL.

NOTE: SOME VEHICLES MAY FISHWIRE THROUGH END OF FRAME

CONICAL TOOTHED WASHER ORIENTATION DIAGRAM

PERIODICALLY CHECK THIS GOOSENECK HITCH TO ENSURE THAT ALL FASTENERS ARE TIGHT AND THAT ALL STRUCTURAL COMPONENTS ARE SOUND.

WARNING!! BRAKE, FUEL, AND ELECTRICAL LINES MAY NEED TO BE LOOSENED OR REPOSITIONED TO PROVIDE CLEARANCE FOR NEW HARDWARE. ALL MODELS REQUIRE MODIFICATION OR REMOVAL OF HEAT SHIELDS. ON SHORT BED MODELS, CHECK FOR ADEQUATE TURNING CLEARANCE BETWEEN THE FRONT OF ALL TRAILERS AND THE TRUCK CAB. ON TWO WHEEL DRIVE TRUCKS A CLEARANCE CHECK MUST BE PERFORMED WHEN TRUCK IS LOADED AND UNLOADED TO VERIFY THE INVERTED BALL WILL NOT INTERFERE WITH THE TOP OF THE DIFFERENTIAL



INSTALLATION STEPS:

1. If present temporarily remove wheel well cover, by removing (6) fasteners using T-25 socket, on both sides of vehicle. Set aside wheel well and hardware for trim and reinstallation.
2. Remove (4) fasteners holding rear heat shield using a 13mm socket and return to owner. Lower exhaust by locating (4) exhaust hangers along exhaust system. Support exhaust to avoid damaging.

3. Run a ½"-13 bolt or tap through front cross arm [D] and rear cross arm's [C] threads to remove power coating and/or debris. Install front and rear cross arm by sliding between frame and bottom of truck bed, approximately above rear tire. Once cross arms span across vehicle resting on both frame rails and in correct position, see **FIGURE A**, rotate cross arms vertically.

NOTE: Outside tapped holes in front and rear cross arms are offset by 1/8" and cross arms need to be rotated so holes are offset towards frame, see **FIGURE B**. A crescent wrench can be used as a lever on cross arm to ease rotating process.
NOTE: Temporarily loosening (6) fasteners holding bed to frame, using 18mm socket may ease rotation of cross arm.

4. Loosely attach center section to cross arms.
NOTE: Center section cylinder should offset towards rear of vehicle. Verify center locator is inserted into center section cylinder prior to installing.
NOTE: Applying force to center section towards truck bed will help install hardware in correct position.

5. Secure ½" U-bolts [2] on inside of frame rail, avoiding brake lines, on both sides of vehicle. Fishwire (2) 5/8" carriage bolts [4] with CM-SP9 spacers [1] in position through access hole. Leave fishwires [14] attached to hardware to prevent loss of hardware in vehicle frame, see **FISHWIRE TECHNIQUE** on PAGE 1. **FOR LONG BOX (8') MODELS**, the mounting plates [E] and hardware will need to be installed to shift the kit rearward on the vehicle 2 1/2" for bed support clearance (**SEE PAGE 1 "MOUNTING LOCATIONS"**). Attach side plate to frame and carefully remove fishwire. Secure side plate to frame rail using (2) 5/8" [7] and (4) ½" [6] flange nuts on both sides of vehicle, adjust cross arms as needed.

6. Raise bracket [E] into mounting location, on both sides of vehicle. Use 5/8" hex bolt [3] with 5/8" washer [9] to secure bracket to cross arms.
7. Attach side plates to cross arms. Insert 5/8" hex bolt [3] with 5/8" washer [9] through front flange of side plate and into threaded cross arms holes on both sides of vehicle.

NOTE: Be sure center section is centered on vehicle by verifying sides of center section are in same location on bed ribs.

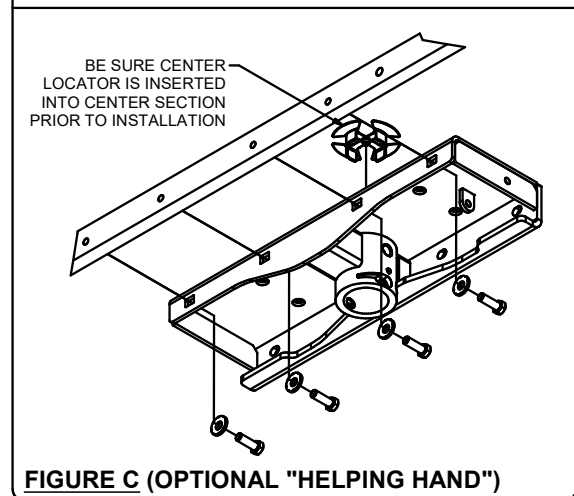
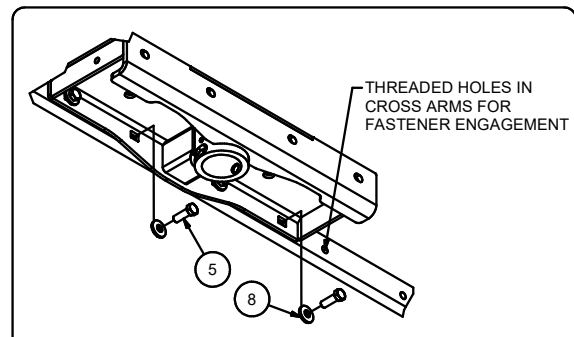
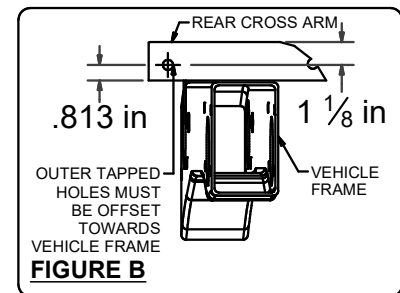
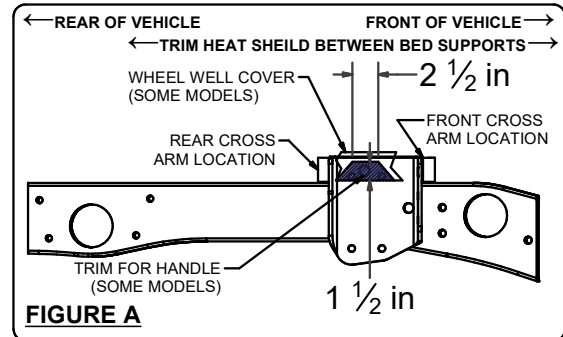

PERIODICALLY CHECK THIS GOOSENECK HITCH TO ENSURE THAT ALL FASTENERS ARE TIGHT AND THAT ALL STRUCTURAL COMPONENTS ARE SOUND.

WARNING!!



BRAKE, FUEL, AND ELECTRICAL LINES MAY NEED TO BE LOOSENED OR REPOSITIONED TO PROVIDE CLEARANCE FOR NEW HARDWARE. ALL MODELS REQUIRE MODIFICATION OR REMOVAL OF HEAT SHIELDS. ON SHORT BED MODELS, CHECK FOR ADEQUATE TURNING CLEARANCE BETWEEN THE FRONT OF ALL TRAILERS AND THE TRUCK CAB. ON TWO WHEEL DRIVE TRUCKS A CLEARANCE CHECK MUST BE PERFORMED WHEN TRUCK IS LOADED AND UNLOADED TO VERIFY THE INVERTED BALL WILL NOT INTERFERE WITH THE TOP OF THE DIFFERENTIAL

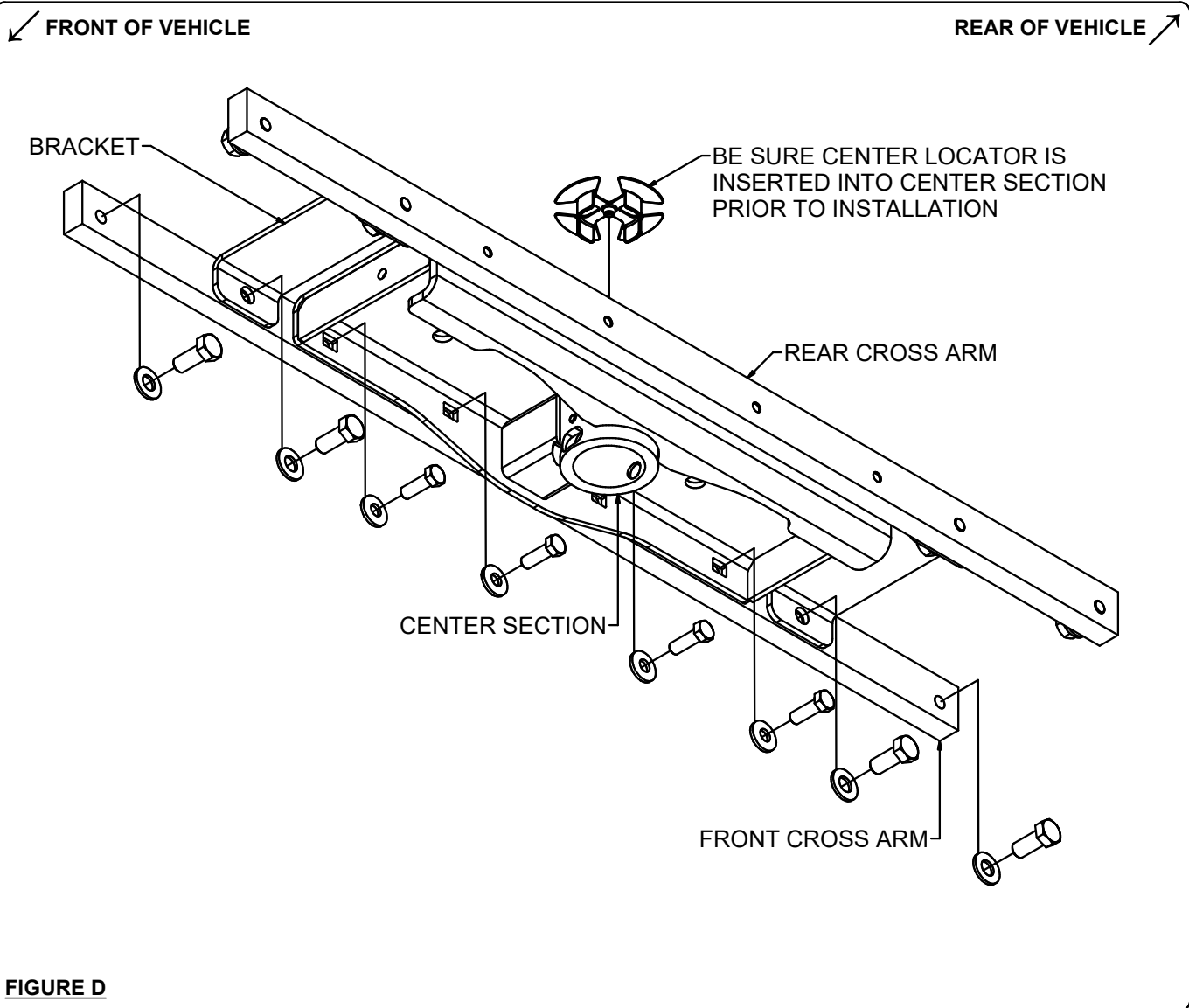

INSTALLATION STEPS CONTINUED:

8. Torque all fasteners in following order:

FIRST: Torque side plates and mounting plates - long box models, to truck frame on both sides.

SECOND: Torque center section, brackets and mounting plates - long box models, to front and rear cross arms.

THIRD: Torque side plates to front and rear cross arms.

Torque all 5/8" fasteners to 180 ft-lbs, and 1/2" fasteners to 110 ft-lbs.

9. Reinstall vehicle components removed in Step 1. Trim wheel well liner if present using **FIGURE A** as a trim diagram.

(REFER TO 60611 GOOSENECK HITCH INSTRUCTIONS FOR INSTALLATION COMPLETION AND OPERATING PROCEDURES)

***** DO NOT DRILL DIMPLES IN TRUCK BED FOR THE GOOSENECK BALL *****

PERIODICALLY CHECK THIS GOOSENECK HITCH TO ENSURE THAT ALL FASTENERS ARE TIGHT AND THAT ALL STRUCTURAL COMPONENTS ARE SOUND.

****DO NOT EXCEED RECOMMENDED VEHICLE TOWING WEIGHT!****

CAB TO TRAILER CLEARANCE

****REMOVAL OF REAR WINDOW ACCESSORIES MAY BE REQUIRED.****

TRAILER

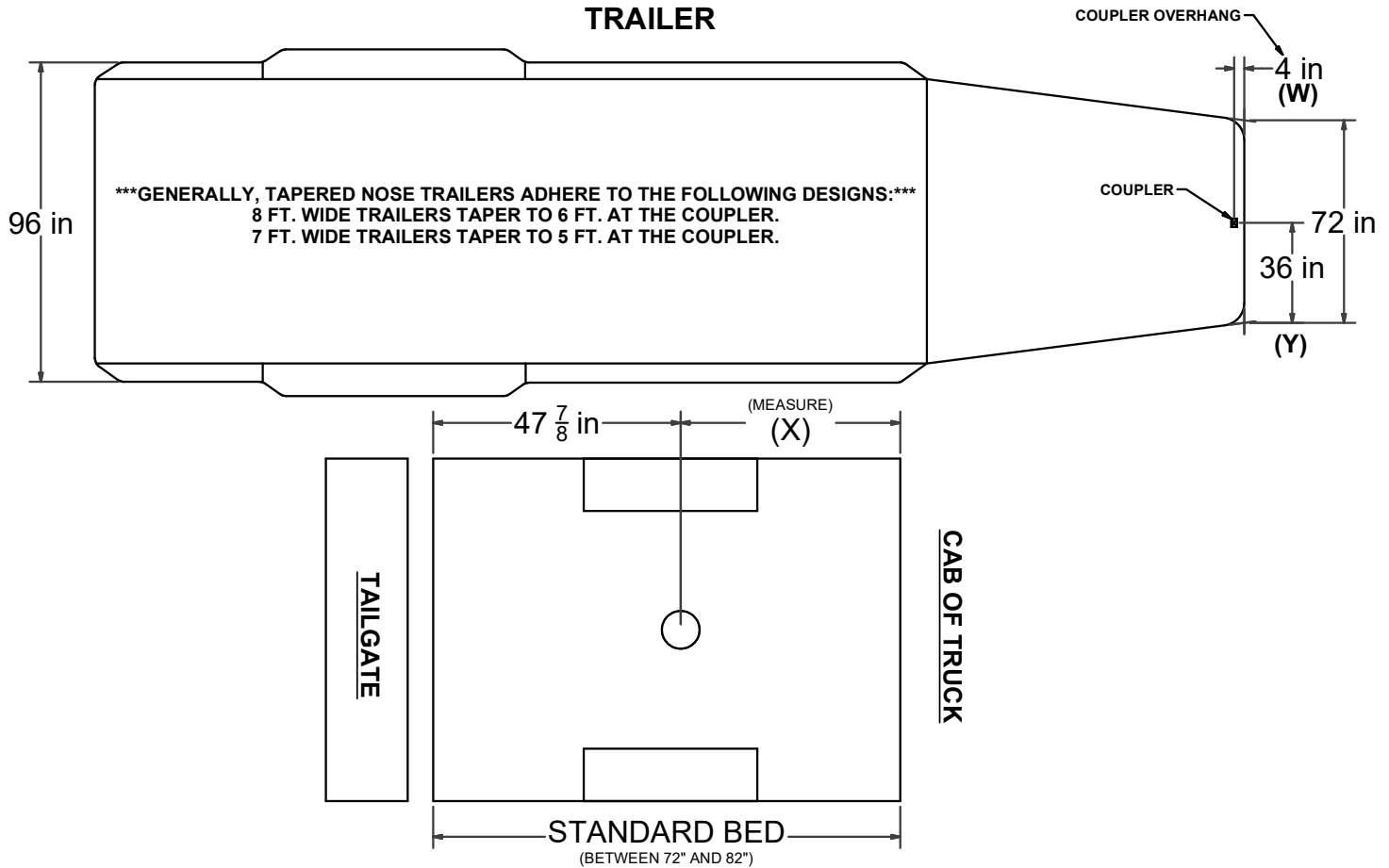

CLEARANCE CALCULATION

$$(CAB TO BALL CENTER) - \frac{1}{2} (TRAILER WIDTH) = (MINIMUM CLEARANCE)$$

$$(X) - (Y) = (Z)$$

IF THERE IS AN OVERHANG FROM THE COUPLER THEN THE EQUATION IS:

$$[(X) - (W)] - (Y) = (Z)$$

IF (Z) IS POSITIVE, TRAILER **WILL NOT** INTERFERE WITH CAB OF TRUCK.
 IF (Z) IS NEGATIVE, TRAILER **WILL** INTERFERE WITH CAB OF TRUCK!!!

EXAMPLE:

STANDARD TRAILER

$$X - Y = Z$$

$$35 - 36 = -1$$

(TRAILER **WILL INTERFERE** WITH CAB)

TRAILER WITH OVERHANG

$$[(X) - (W)] - Y = Z$$

$$[35 - 4] - 36 = -5$$

(TRAILER **WILL INTERFERE** WITH CAB)

YOUR CALCULATION:

(CAB TO BALL CENTER) _____

(COUPLER OVERHANG) _____

1/2 (TRAILER WIDTH) _____

(MINIMUM CLEARANCE) _____