

**\*\*DO NOT EXCEED RECOMMENDED VEHICLE TOWING WEIGHT!\*\***

**60611**



**GOOSENECK HITCH**

**WARNING!!** BRAKE, FUEL, AND ELECTRICAL LINES MAY NEED TO BE LOOSENED OR REPOSITIONED TO PROVIDE CLEARANCE FOR NEW HARDWARE. SOME MODELS REQUIRE MODIFICATION OR REMOVAL OF HEAT SHIELDS. ON SHORT BED MODELS, CHECK FOR ADEQUATE TURNING CLEARANCE BETWEEN THE FRONT OF ALL TRAILERS AND THE TRUCK CAB. ON TWO WHEEL DRIVE TRUCKS A CLEARANCE CHECK MUST BE PERFORMED WHEN TRUCK IS LOADED AND UNLOADED TO VERIFY THE INVERTED BALL WILL NOT INTERFERE WITH THE TOP OF THE DIFFERENTIAL

Hardware List			
ITEM	QTY	PART NUMBER	DESCRIPTION
1	2	60612-CLA	SAFETY CHAIN LOOP ASSEMBLY
1.1	1	60612-UB	5/8" - 11 x 2.50" x 3.25" U-BOLT
1.2	4	5/8"	WASHER WIDE
1.3	2	CM-C113-UBS	U-BOLT SPRING
1.4	2	5_8-11 NYLOCK HEX NUT	5/8"-11-2B UNC NUT
2	2	3/8"	WASHER
3	3	M5-.080 x 20mm	FLAT HEAD C'SUNK CAP SCREW
4	1	M5 x 30mm HHFS	HEX HEAD FLANGE SCREW
5	1	M5-0.80 NYLOCK HEX NUT	NYLOCK HEX NUT

Parts List			
ITEM	QTY	PART NUMBER	DESCRIPTION
A	1	60611-WA	GOOSENECK CENTER SECTION
B	1	60611-CL	CENTER LOCATOR / TRIM SHIELD
C	1	66165	RUBBER COVER
D	1	CM-C60-B	TURNOVER BALL COMPLETE
E	1	CM-C60-H	VINYL HANDLE GRIP
F	1	CM-C60-R	.375" HANDLE ROD
G	1	CM-C600-CR	3.75 DIA. x .375" CHROME RING
H	1	CM-C600-CLP	CAST LOCK PIN
I	1	CM-C60-CS	7.5 LB COMPRESSION SPRING
J	1	CM-UE1	.300" U-SHAPED EDGING

TOOLS REQUIRED
SAFETY GLASSES
EAR PROTECTION
RATCHET
8mm & 15/16" SOCKETS
8mm END WRENCH
DRILL
3/16" & 5/8" DRILL BIT
4" HOLE SAW
#3 ALLEN WRENCH
CUTTING FLUID
RUST INHIBITOR

NOTE: A SMALL RIGHT ANGLE DRILL & 3/4" STEP BIT MAY EASE THE INSTALL PROCESS

WHEN BALL IS INVERTED, INSERT SUPPLIED RUBBER COVER

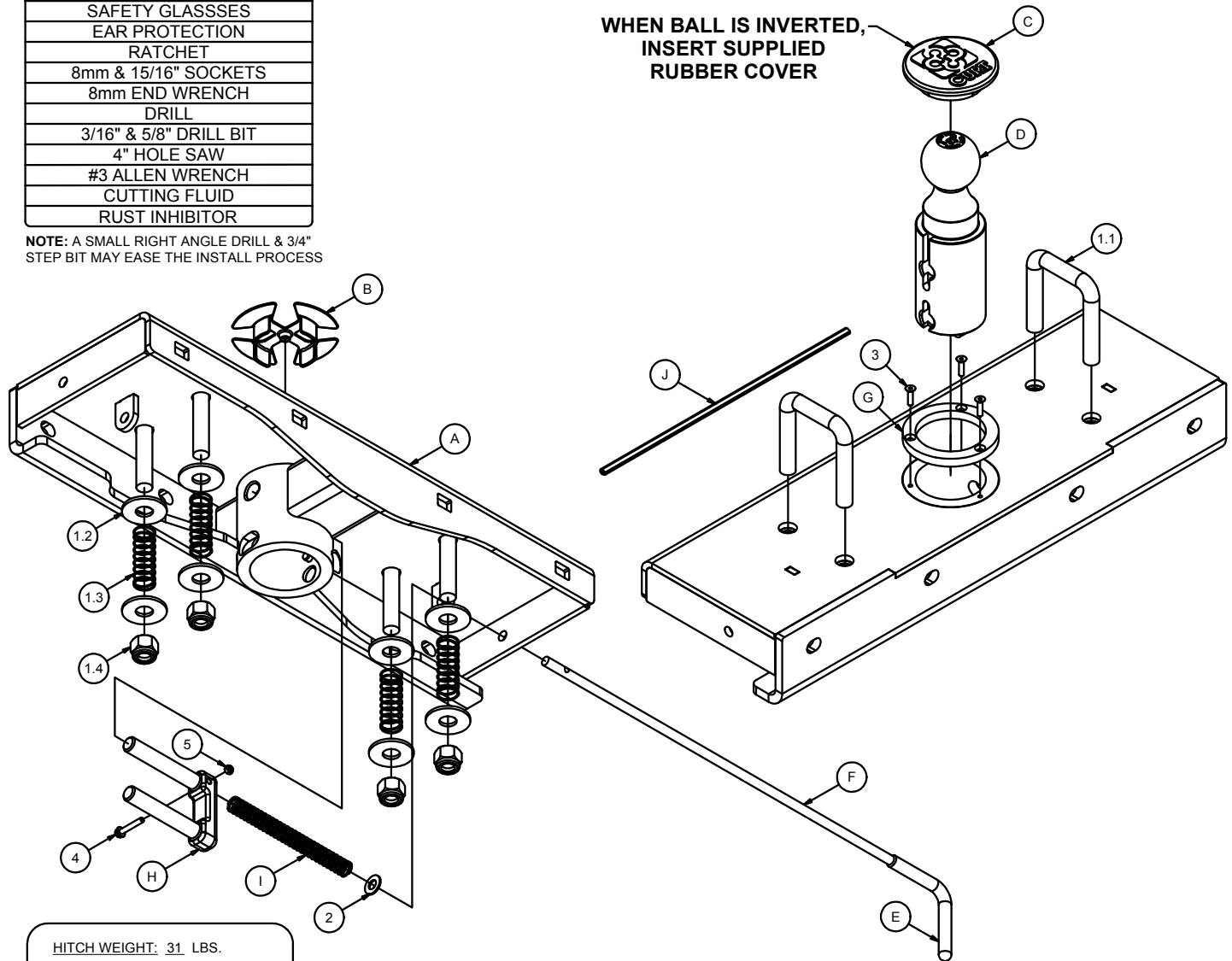

HITCH WEIGHT: 31 LBS.

INSTALL TIME

PROFESSIONAL: 20 MINUTES

NOVICE (DIY): 40 MINUTES

**PERIODICALLY CHECK THIS GOOSENECK HITCH TO ENSURE THAT ALL FASTENERS ARE TIGHT AND THAT ALL STRUCTURAL COMPONENTS ARE SOUND.**

**\*\*DO NOT EXCEED RECOMMENDED VEHICLE TOWING WEIGHT!\*\***

**60611**

## GOOSENECK HITCH

**WARNING!!** BRAKE, FUEL, AND ELECTRICAL LINES MAY NEED TO BE LOOSENED OR REPOSITIONED TO PROVIDE CLEARANCE FOR NEW HARDWARE. SOME MODELS REQUIRE MODIFICATION OR REMOVAL OF HEAT SHIELDS. ON SHORT BED MODELS, CHECK FOR ADEQUATE TURNING CLEARANCE BETWEEN THE FRONT OF ALL TRAILERS AND THE TRUCK CAB. ON TWO WHEEL DRIVE TRUCKS A CLEARANCE CHECK MUST BE PERFORMED WHEN TRUCK IS LOADED AND UNLOADED TO VERIFY THE INVERTED BALL WILL NOT INTERFERE WITH THE TOP OF THE DIFFERENTIAL.

### **INSTALLATION STEPS:** (After subkit installation)

1. Drill pilot hole from underneath the truck bed through the hole in center locator / trim shield (B) using a 3/16" drill bit, see **FIGURE A**.
2. Drill two holes for safety chain loops from underneath the truck bed using a 5/8" hole saw. **NOTE:** A short pilot bit with a small right angle drill will ease the process of drilling over the exhaust. Finish these two holes above the bed. Use the center section (A) as a drill guide. **NOTE:** Drill holes should go through the low rib section in the truck bed, see **FIGURE B**.
3. Drill hole from top of truck using 4" hole saw using caution to not drill through the center locator / trim shield (B). **NOTE:** Use cutting fluid to ease this process. Remove the center locator by pulling it up through the hole.
4. Deburr holes and spray exposed metal with rust inhibitor. **OPTIONAL:** Insert rubber edging (J) around 4" hole.
5. Place chrome ring (G) into position and fasten with three flat head cap screws (3).
6. Place two U-bolts (1.1) down through the holes drilled in step 2.
7. From underneath the truck place a washer (1.2), a spring (1.3), a washer (1.2) and a nut (1.4) on each of the four U-bolt legs. Tighten the nuts until flush with the bottom of the U-bolt, see **PAGE 1**.
8. Insert cast lock pin (H) into the ball cylinder with handle hole located on top.
9. Insert handle (F) from outside vehicle, through the holes center section, see **PAGE 1**. Handle may be installed on driver or passenger side, depending on preference. **NOTE:** Some models may require use of a pliers to bend the metal flange below the bed outward to allow the handle to move without interference.
10. Slide one 3/8" washer (2) and the compression spring (I) over handle before inserting the handle rod (F) into the lock pin (H). Insert handle into locking pin and secure with hex head flange screw (4) and nylock nut (5), see **PAGE 1**. **NOTE:** If needed, add or remove a 3/8" washer (2) to ensure proper pull length of lock pin.
11. Reinstall spare tire.

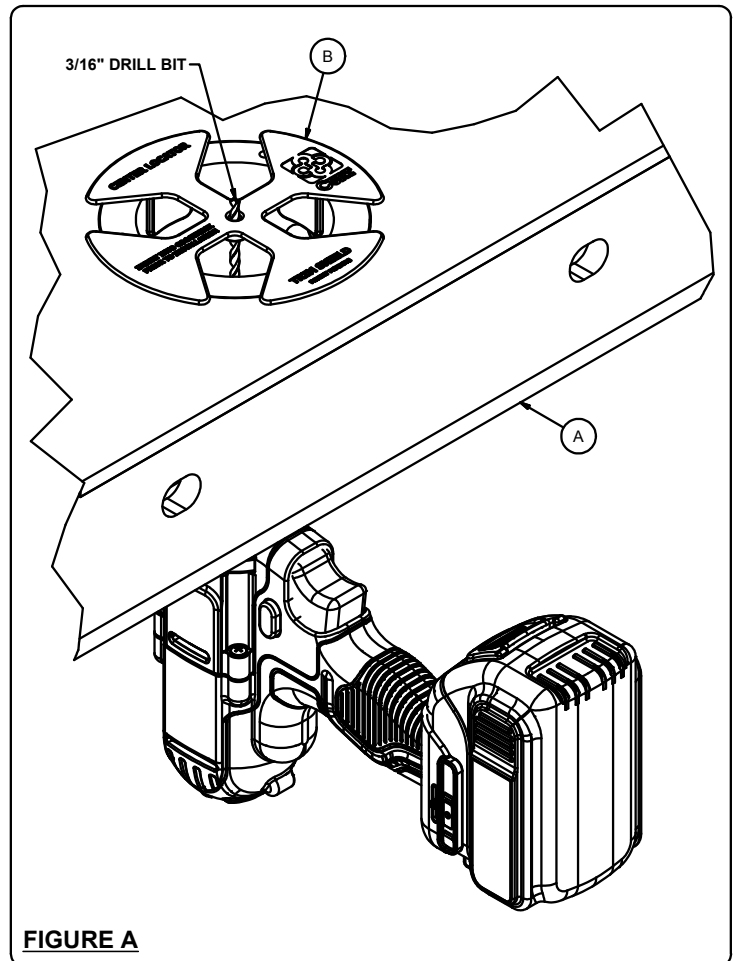

**FIGURE A**

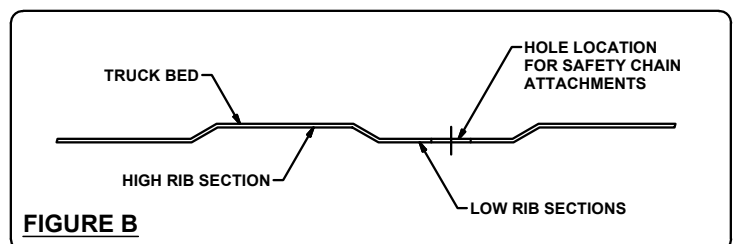

**FIGURE B**

**PERIODICALLY CHECK THIS GOOSENECK HITCH TO ENSURE THAT ALL FASTENERS ARE TIGHT AND THAT ALL STRUCTURAL COMPONENTS ARE SOUND.**

**\*\*DO NOT EXCEED RECOMMENDED VEHICLE TOWING WEIGHT!\*\***

**60611**

## **GOOSENECK HITCH**

**WARNING!!** BRAKE, FUEL, AND ELECTRICAL LINES MAY NEED TO BE LOOSENEED OR REPOSITIONED TO PROVIDE CLEARANCE FOR NEW HARDWARE. SOME MODELS REQUIRE MODIFICATION OR REMOVAL OF HEAT SHIELDS. ON SHORT BED MODELS, CHECK FOR ADEQUATE TURNING CLEARANCE BETWEEN THE FRONT OF ALL TRAILERS AND THE TRUCK CAB. ON TWO WHEEL DRIVE TRUCKS A CLEARANCE CHECK MUST BE PERFORMED WHEN TRUCK IS LOADED AND UNLOADED TO VERIFY THE INVERTED BALL WILL NOT INTERFERE WITH THE TOP OF THE DIFFERENTIAL

### **60611 OPERATION:**

1. Place handle in the unlock position by pulling it out as far as possible and rotating it clockwise. **NOTE:** Never operate vehicle with the handle in the unlocked position.
2. Insert ball into the desired position in the cylinder by aligning the ball groove with the cylinder pin. If the groove and pin are not aligned simply rotate the ball until it drops into place.
3. Place handle in the lock position by rotating it counter clockwise until locking pin snaps back into position.

### **BEFORE TOWING THE FIRST TIME:**

- Verify adequate turning clearance between the truck cab / box corners and trailer(s).
- Check truck box clearance. There should be a minimum clearance of 6" between the bottom of the trailer(s) overhang and the top of the box sides.
- Verify the inverted ball will not interfere with the top of the differential when hauling heavy loads. This is especially important on two wheel drive models.
- Verify all hardware is torqued to the proper specification.
- Verify the trailer safety chain length. Too much slack in the chain may prevent maintaining control in the event of separation. Leave only enough slack to allow full turning without interference.
- Verify the trailer attachments to the safety chain loops are secure (cannot be shaken free during towing).

### **BEFORE TOWING EVERY TIME:**

- Ensure all fasteners are tight and that all structural components are sound. **NOTE:** Do not tow trailer with worn or damaged parts.
- Attach trailer securely to both of the safety chain loops.
- Ensure the handle is in the lock position and that the locking pin passes completely through the ball and both walls of the hitch cylinder.
- Ensure the trailer weight does not exceed any part of your towing system. Be sure load is heavier towards front of the trailer while not exceeding the hitch tongue weight. Be sure trailer load is secured to prevent shifting and centered from left to right. **NOTE:** Never load the trailer heavier behind the trailer axle.
- Check trailer tires to ensure they are inflated to the proper specification.
- Verify trailer lights, electric brakes and breakaway switches are working properly.

### **MAINTENANCE:**

- Keep hitch ball, cylinder and trailer coupler lubricated regularly. Use silicone spray or equivalent to prevent wear / rust.
- Keep hitch assembly and trailer coupler free of dirt and other foreign debris.

### **WARNING!!**

- Vehicle performance (braking, handling, acceleration, turning radius) can be drastically affected by the trailer. Allow additional time / space for stopping, changing lanes, passing and turning.
- Do not tow more than one trailer at a time. This may cause loss of control.

**PERIODICALLY CHECK THIS GOOSENECK HITCH TO ENSURE THAT ALL FASTENERS ARE TIGHT AND THAT ALL STRUCTURAL COMPONENTS ARE SOUND.**

**\*\*DO NOT EXCEED RECOMMENDED VEHICLE TOWING WEIGHT!\*\***

# 60701 SUBKIT

# CHEVY & GMC 2500 / 3500

**WARNING!!** BRAKE, FUEL, AND ELECTRICAL LINES MAY NEED TO BE LOOSENED OR REPOSITIONED TO PROVIDE CLEARANCE FOR NEW HARDWARE. ALL MODELS REQUIRE MODIFICATION OR REMOVAL OF HEAT SHIELDS. ON SHORT BED MODELS, CHECK FOR ADEQUATE TURNING CLEARANCE BETWEEN THE FRONT OF ALL TRAILERS AND THE TRUCK CAB. ON TWO WHEEL DRIVE TRUCKS A CLEARANCE CHECK MUST BE PERFORMED WHEN TRUCK IS LOADED AND UNLOADED TO VERIFY THE INVERTED BALL WILL NOT INTERFERE WITH THE TOP OF THE DIFFERENTIAL



Parts List			
ITEM	QTY	PART NUMBER	DESCRIPTION
1	2	CM-SP9	.375 x 1.25 x 2.50" SQUARE HOLE SPACER
2	2	CM-1215-UBS	1/2-13 x 5 1/4 x 6 x 1 1/2 SQ U-BOLT
3	8	10-10038	HHCS, 5/8-11 UNC, 1-1/2, GRD8
4	2	10-10292	BOLT, CAR, 5/8-11 UNC, 1-3/4, GRD8, YZ
5	8	10-10334	HHCS, 1/2-13 UNC, 1-1/2, GRD8, YZ
6	4	20-00062	NUT, SER-FLANGE, 1/2-13 UNC, GRD8, YZ
7	6	20-00105	NUT, SER-FLANGE, 5/8-11 UNC, GRD8, YZ
8	8	30-00149	WASHER, S-CON, 1/2, YZ
9	8	30-00131	WASHER, FLAT, 5/8
10	4	30-00204	WASHER, FLAT, 5/8, YZ
11	4	10-10296	HHCS, 5/8-11 UNC, 1-3/4, GRD8
12	2	5_8 FISHWIRE	5/8" FISHWIRE

Parts List			
ITEM	QTY	PART NUMBER	DESCRIPTION
A	1	60701-DS	DRIVER SIDE PLATE
B	1	60701-PS	PASSENGER SIDE PLATE
C	1	60701-RCA	REAR CROSS ARM (47.00")
D	1	60701-FCA	FRONT CROSS ARM (47.25")
E	2	60701-BR	BRACKET
F	2	60701-MP	MOUNTING PLATE

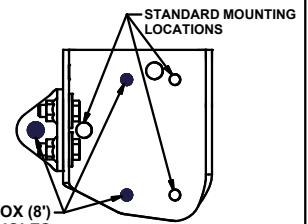

LONG BOX (8") MOUNTING HOLES  
**MOUNTING LOCATIONS**

DESIGNED FOR USE WITH 60611 CENTER SECTION (NOT INCLUDED IN SUBKIT)

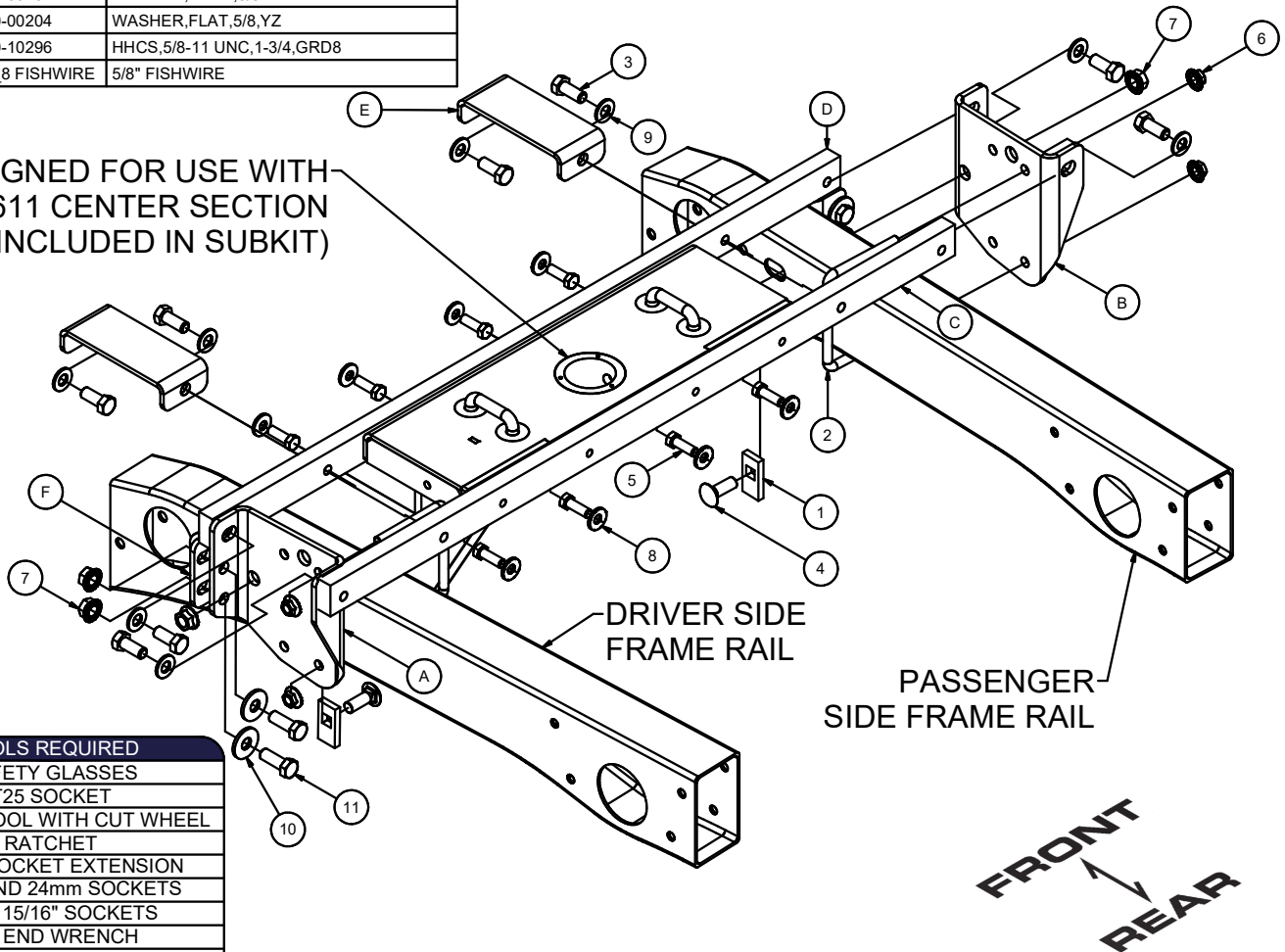

TOOLS REQUIRED	
SAFETY GLASSES	
T25 SOCKET	
ROTARY TOOL WITH CUT WHEEL	
RATCHET	
3" & 6" SOCKET EXTENSION	
13, 18 AND 24mm SOCKETS	
3/4" & 15/16" SOCKETS	
3/4" END WRENCH	
ADJUSTABLE WRENCH	
TORQUE WRENCH	

SUBKIT WEIGHT: 66 LBS.

**INSTALL TIME**

PROFESSIONAL: 45 MINUTES

NOVICE (DIY): 90 MINUTES

**INSTALL NOTES:**

- LOWER SPARE TIRE
- TRIM HEAT SHIELD
- NO MEASURING DRILL LOCATIONS
- NO DRILLING INTO FRAME
- NO LOWERING EXHAUST

**FISHWIRE TECHNIQUE**

INSERT COILED END OF FISHWIRE TOOL THROUGH HITCH MOUNTING HOLE IN VEHICLE FRAME RAIL AND OUT THE ACCESS HOLE. PASS COILED END OF FISHWIRE THROUGH SPACER AND THREAD BOLT INTO COIL. KINK WIRE TO KEEP SPACER SEPERATE FROM BOLT AS SHOWN. PULL FISHWIRE, SPACER, AND BOLT THROUGH FRAME AND OUT MOUNTING HOLE. USE FISHWIRE TO GUIDE HITCH DURING MOUNTING AND PREVENT LOSS OF BOLT / SPACER INSIDE FRAME RAIL.

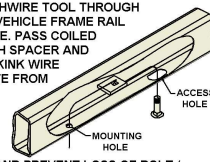

\*\*NOTE: SOME VEHICLES MAY FISHWIRE THROUGH END OF FRAME\*\*

**CONICAL TOOTHED WASHER ORIENTATION DIAGRAM**

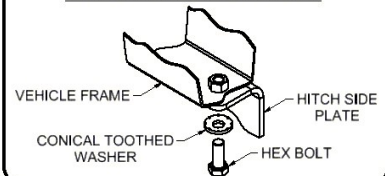

**PERIODICALLY CHECK THIS GOOSENECK HITCH TO ENSURE THAT ALL FASTENERS ARE TIGHT AND THAT ALL STRUCTURAL COMPONENTS ARE SOUND.**

**\*\*DO NOT EXCEED RECOMMENDED VEHICLE TOWING WEIGHT!\*\***

## 60701 SUBKIT

## CHEVY & GMC 2500 / 3500

**WARNING!!** BRAKE, FUEL, AND ELECTRICAL LINES MAY NEED TO BE LOOSENED OR REPOSITIONED TO PROVIDE CLEARANCE FOR NEW HARDWARE. ALL MODELS REQUIRE MODIFICATION OR REMOVAL OF HEAT SHIELDS. ON SHORT BED MODELS, CHECK FOR ADEQUATE TURNING CLEARANCE BETWEEN THE FRONT OF ALL TRAILERS AND THE TRUCK CAB. ON TWO WHEEL DRIVE TRUCKS A CLEARANCE CHECK MUST BE PERFORMED WHEN TRUCK IS LOADED AND UNLOADED TO VERIFY THE INVERTED BALL WILL NOT INTERFERE WITH THE TOP OF THE DIFFERENTIAL



### INSTALLATION STEPS:

1. If present temporarily remove wheel well cover, by removing (6) fasteners using T-25 socket, on both sides of vehicle. Set aside wheel well and hardware for trim and reinstallation.
2. Remove (4) fasteners holding rear heat shield using a 13mm socket and return to owner. Lower exhaust by locating (4) exhaust hangers along exhaust system. Support exhaust to avoid damaging.

3. Run a  $\frac{1}{2}$ "-13 bolt or tap through front cross arm [D] and rear cross arm's [C] threads to remove power coating and/or debris. Install front and rear cross arm by sliding between frame and bottom of truck bed, approximately above rear tire. Once cross arms span across vehicle resting on both frame rails and in correct position, see **FIGURE A**, rotate cross arms vertically.

**NOTE:** Outside tapped holes in front and rear cross arms are offset by  $\frac{1}{8}$ " and cross arms need to be rotated so holes are offset towards frame, see **FIGURE B**.

A crescent wrench can be used as a lever on cross arm to ease rotating process.

**NOTE:** Temporarily loosening (6) fasteners holding bed to frame, using 18mm socket may ease rotation of cross arm.

4. Loosely attach center section to cross arms.

**NOTE:** Center section cylinder should offset towards rear of vehicle. Verify center locator is inserted into center section cylinder prior to installing.

**NOTE:** Applying force to center section towards truck bed will help install hardware in correct position.

5. Secure  $\frac{1}{2}$ " U-bolts [2] on inside of frame rail, avoiding brake lines, on both sides of vehicle. Fishwire (2)  $\frac{5}{8}$ " carriage bolts [4] with CM-SP9 spacers [1] in position through access hole. Leave fishwires [14] attached to hardware to prevent loss of hardware in vehicle frame, see **FISHWIRE TECHNIQUE** on PAGE 1. **FOR LONG BOX (8') MODELS**, the mounting plates [E] and hardware will need to be installed to shift the kit rearward on the vehicle  $2\frac{1}{2}$ " for bed support clearance (SEE PAGE 1 "MOUNTING LOCATIONS"). Attach side plate to frame and carefully remove fishwire. Secure side plate to frame rail using (2)  $\frac{5}{8}$ " [7] and (4)  $\frac{1}{2}$ " [6] flange nuts on both sides of vehicle, adjust cross arms as needed.

6. Raise bracket [E] into mounting location, on both sides of vehicle. Use  $\frac{5}{8}$ " hex bolt [3] with  $\frac{5}{8}$ " washer [9] to secure bracket to cross arms.

7. Attach side plates to cross arms. Insert  $\frac{5}{8}$ " hex bolt [3] with  $\frac{5}{8}$ " washer [9] through front flange of side plate and into threaded cross arms holes on both sides of vehicle.

**NOTE:** Be sure center section is centered on vehicle by verifying sides of center section are in same location on bed ribs.

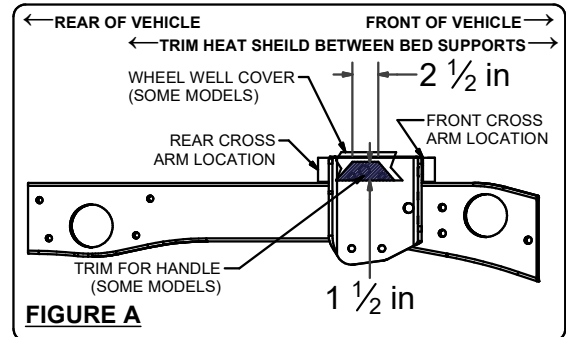

**FIGURE A**

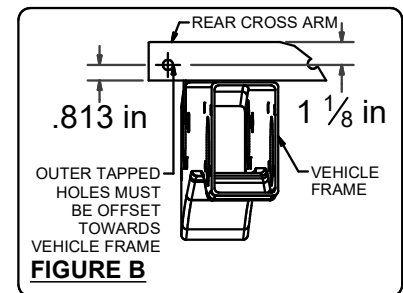

**FIGURE B**

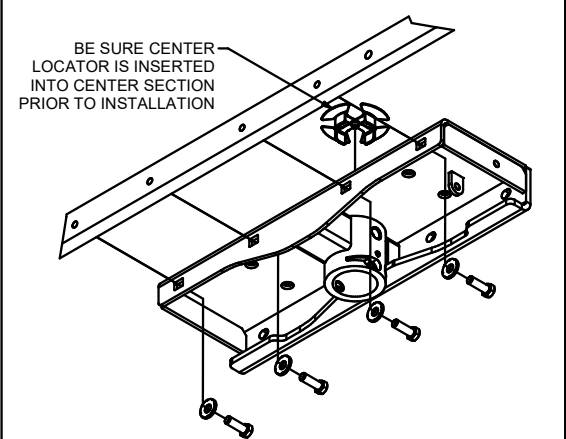
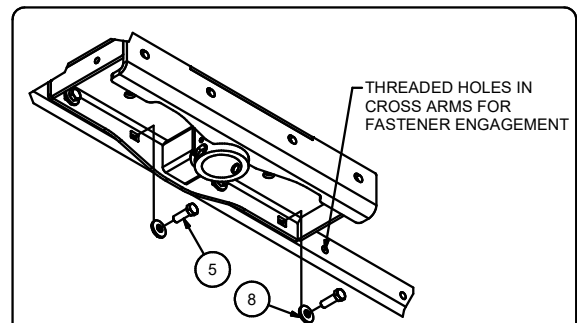

**FIGURE C (OPTIONAL "HELPING HAND")**

**PERIODICALLY CHECK THIS GOOSENECK HITCH TO ENSURE THAT ALL FASTENERS ARE TIGHT AND THAT ALL STRUCTURAL COMPONENTS ARE SOUND.**

**\*\*DO NOT EXCEED RECOMMENDED VEHICLE TOWING WEIGHT!\*\***

**60701 SUBKIT**

**CHEVY & GMC 2500 / 3500**

**WARNING!!** BRAKE, FUEL, AND ELECTRICAL LINES MAY NEED TO BE LOOSENED OR REPOSITIONED TO PROVIDE CLEARANCE FOR NEW HARDWARE. ALL MODELS REQUIRE MODIFICATION OR REMOVAL OF HEAT SHIELDS. ON SHORT BED MODELS, CHECK FOR ADEQUATE TURNING CLEARANCE BETWEEN THE FRONT OF ALL TRAILERS AND THE TRUCK CAB. ON TWO WHEEL DRIVE TRUCKS A CLEARANCE CHECK MUST BE PERFORMED WHEN TRUCK IS LOADED AND UNLOADED TO VERIFY THE INVERTED BALL WILL NOT INTERFERE WITH THE TOP OF THE DIFFERENTIAL

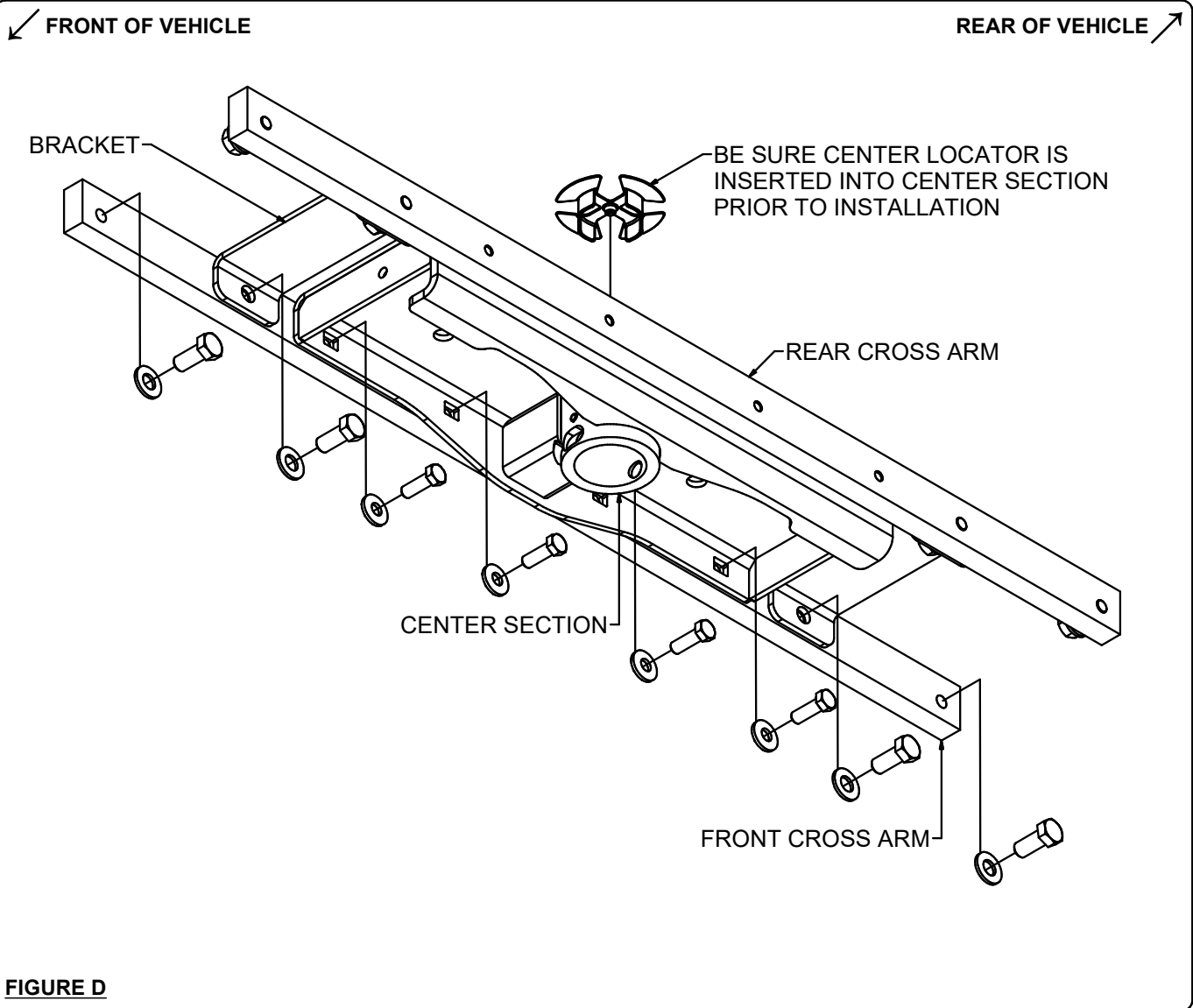

**INSTALLATION STEPS CONTINUED:**

8. Torque all fasteners in following order:

**FIRST:** Torque side plates and mounting plates - long box models, to truck frame on both sides.

**SECOND:** Torque center section, brackets and mounting plates - long box models, to front and rear cross arms.

**THIRD:** Torque side plates to front and rear cross arms.

Torque all 5/8" fasteners to 180 ft-lbs, and 1/2" fasteners to 110 ft-lbs.

9. Reinstall vehicle components removed in Step 1. Trim wheel well liner if present using **FIGURE A** as a trim diagram.

(REFER TO 60611 GOOSENECK HITCH INSTRUCTIONS FOR INSTALLATION COMPLETION AND OPERATING PROCEDURES)  
**\*\*\* DO NOT DRILL DIMPLES IN TRUCK BED FOR THE GOOSENECK BALL \*\*\***

**PERIODICALLY CHECK THIS GOOSENECK HITCH TO ENSURE THAT ALL FASTENERS ARE TIGHT AND THAT ALL STRUCTURAL COMPONENTS ARE SOUND.**

**\*\*DO NOT EXCEED RECOMMENDED VEHICLE TOWING WEIGHT!\*\***

# CAB TO TRAILER CLEARANCE

**\*\*REMOVAL OF REAR WINDOW ACCESSORIES MAY BE REQUIRED.\*\***

## TRAILER

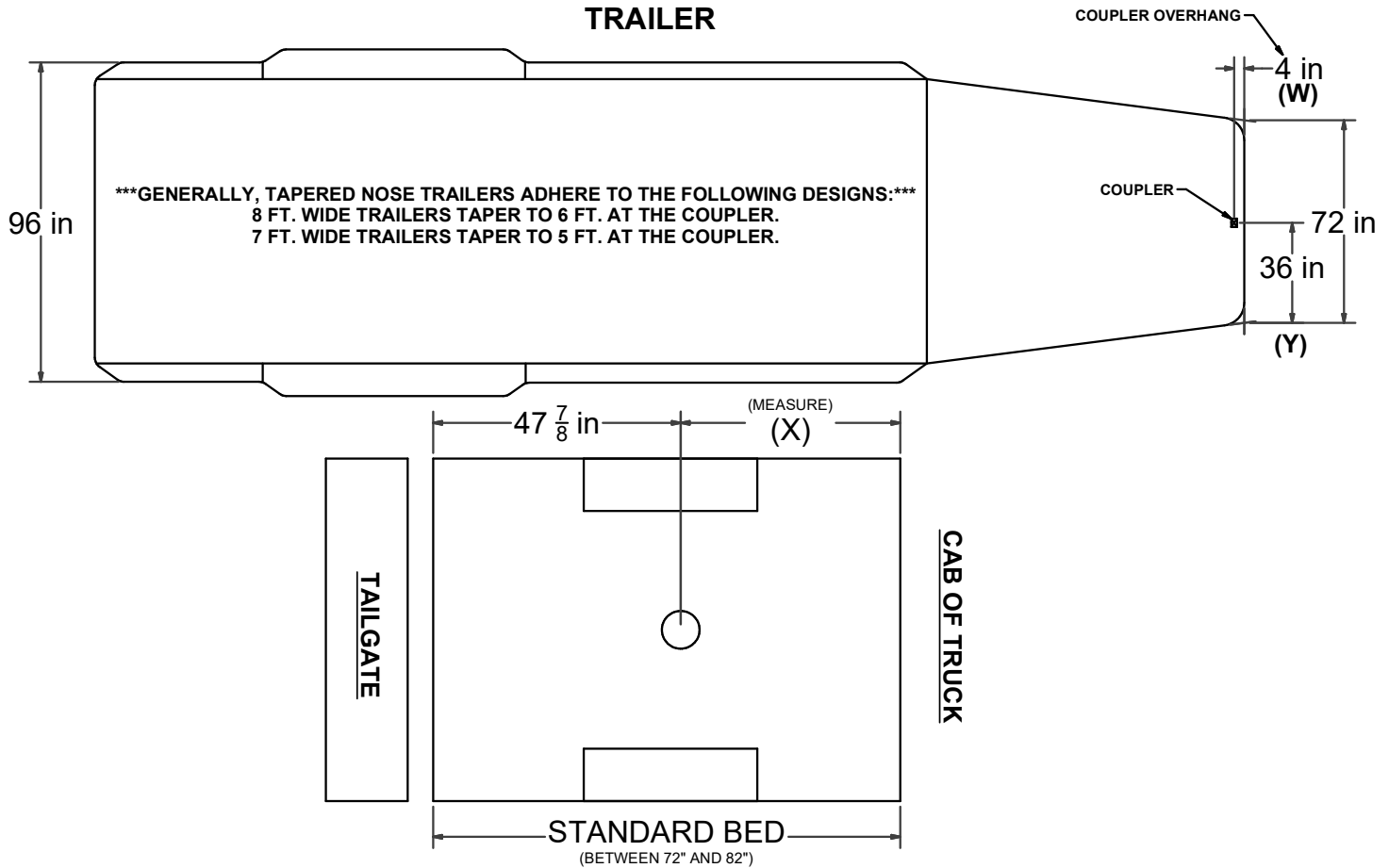

### CLEARANCE CALCULATION

$$(CAB TO BALL CENTER) - \frac{1}{2} (TRAILER WIDTH) = (MINIMUM CLEARANCE)$$

$$(X) - (Y) = (Z)$$

IF THERE IS AN OVERHANG FROM THE COUPLER THEN THE EQUATION IS:

$$[(X) - (W)] - (Y) = (Z)$$

\*\*\*IF (Z) IS POSITIVE, TRAILER **WILL NOT** INTERFERE WITH CAB OF TRUCK.\*\*\*  
 IF (Z) IS NEGATIVE, TRAILER **WILL** INTERFERE WITH CAB OF TRUCK!!!

#### EXAMPLE:

##### STANDARD TRAILER

$$X - Y = Z$$

$$35 - 36 = -1$$

(TRAILER **WILL INTERFERE** WITH CAB)

##### TRAILER WITH OVERHANG

$$[(X) - (W)] - Y = Z$$

$$[35 - 4] - 36 = -5$$

(TRAILER **WILL INTERFERE** WITH CAB)

#### YOUR CALCULATION:

(CAB TO BALL CENTER) \_\_\_\_\_

(COUPLER OVERHANG) \_\_\_\_\_

1/2 (TRAILER WIDTH) \_\_\_\_\_

(MINIMUM CLEARANCE) \_\_\_\_\_