

CURT PINTLE INSTALLATION AND OPERATING INSTRUCTIONS

48332-INS



WARNING: * DO NOT EXCEED VEHICLE MANUFACTURER'S RECOMMENDED TOWING CAPACITY *****



PART #	PINTLE GTW	VERTICAL LOAD	BALL GTW	BALL DIAMETER
48180	16,000 lbs	1,600 lbs	6,000 lbs	1-7/8"
48190	16,000 lbs	1,600 lbs	10,000 lbs	2"
48200	16,000 lbs	1,600 lbs	16,000 lbs	2-5/16"
48205	10,000 lbs	2,000 lbs	-	-
48210	20,000 lbs	4,000 lbs	-	-
48215	30,000 lbs	8,000 lbs	-	-
48231	60,000 lbs	12,000 lbs	-	-

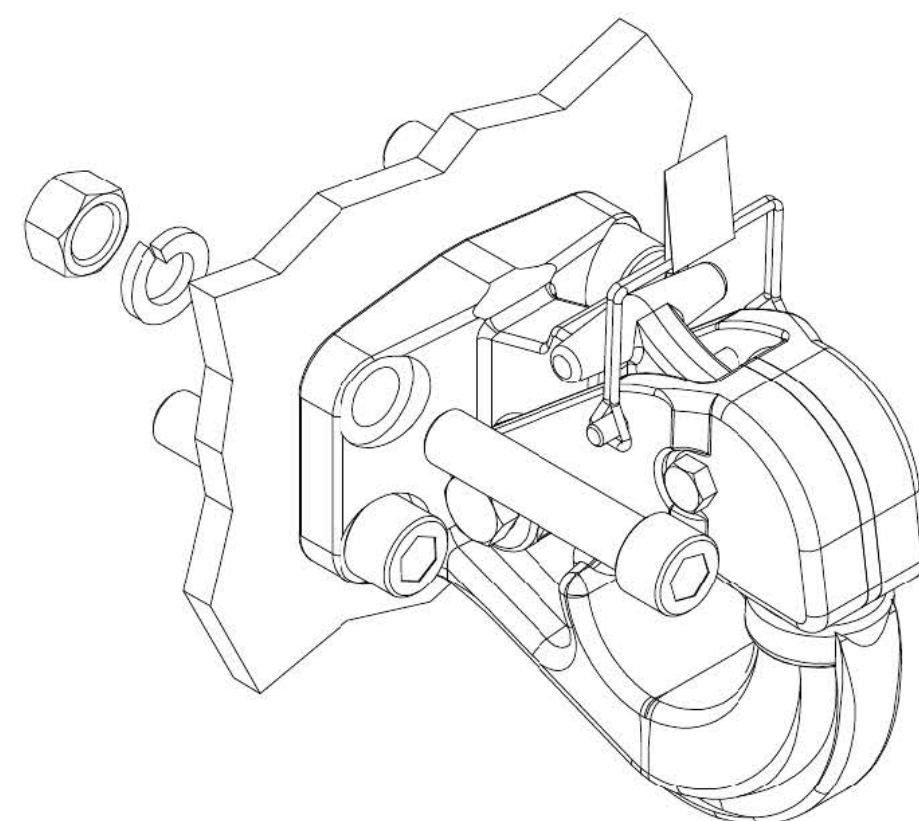

NOTE: VIEW REPRESENTATIVE ONLY. PINTLE, HARDWARE, AND MOUNT MAY VARY

TORQUE CHART

PART #	HARDWARE	TORQUE
48180, 48190, 48200, 48205, 48210, 48215, 48330	1/2"	90 ft-lbs
48231, 48332	5/8"	200 ft-lbs

MOUNTING INSTRUCTIONS

1. Mounting structure must be capable of supporting the rated pintle hook capacity in accordance with SAE J847.
2. Only use CURT supplied mounting hardware torqued to the proper specification. See Torque Chart

OPERATING INSTRUCTIONS

PINTLE HOOK

1. Open latch by removing safety pin and pulling lock while lifting latch.
2. Position drawbar eye over the horn of the pintle and lower into place.
3. Push latch closed and insert safety pin.

BALL HITCH

1. Open latch by removing safety pin and pulling lock while lifting latch.
2. Replace safety pin to retain latch in open position.
3. Position ball coupler over ball and lower into place, follow coupler manufacturer's instructions.

BEFORE TOWING

1. Ensure all fasteners are tight and that all structural components are sound.
Note: Never tow with worn or damaged parts.
2. Attach trailer securely to safety chains loops.
3. Maintain adequate tongue load to properly control the trailer (approximately 10%) not to exceed ratings.
4. For off-road applications reduce the rated capacities by 25%.
5. Support the rear of trailer to avoid load shift when loading or unloading a trailer coupled to the tow vehicle.
6. Clean and lubricate moving parts regularly to ensure proper function.

WARNING!!

1. Vehicle performance (braking, handling, acceleration, turning radius) can be drastically affected by towing a trailer. Allow additional time / space for stopping, changing lanes, passing and turning.
2. Do not tow more than one trailer at a time.
3. Severe bumps can damage your towing system. Avoid or drive slowly over rough terrain.
4. Do not damage the latch. Be particularly careful with the drawbar when coupling and uncoupling.
5. Other steps and inspections are also required. Consult D.O.T. regulations and American Trucking Association for complete towing procedures.

PERIODICALLY CHECK TOWING SYSTEM TO ENSURE THAT ALL FASTENERS ARE TIGHT AND THAT ALL STRUCTURAL COMPONENTS ARE SOUND.