

31433

# JEEP WRANGLER 75th ANNIVERSARY EDITION

GROSS LOAD CAPACITY WHEN USED AS A WEIGHT CARRYING HITCH: 3,500 LBS. TRAILER WEIGHT & 525 LBS. TONGUE WEIGHT.  
GROSS LOAD CAPACITY WHEN USED AS A STRAIGHT LINE PULL: 9,000 LBS. MAX. LINE PULL.



**WARNING: \*\*\* DO NOT EXCEED VEHICLE MANUFACTURER'S RECOMMENDED TOWING CAPACITY. \*\*\***



Parts List			
1	6	1/2-13 x 1 1/2	CARRIAGE BOLT
2	6	CM-SP10	.250 x 1.00 x 2.50" SQUARE HOLE SPACER
3	6	HFN 1213	HEX FLANGE NUT
4	6	1_2 FISHWIRE	1/2" FISHWIRE

TOOLS REQUIRED
RATCHET
TORQUE WRENCH
15mm & 3/4" SOCKETS
6" SOCKET EXTENSION
SAFETY GLASSES

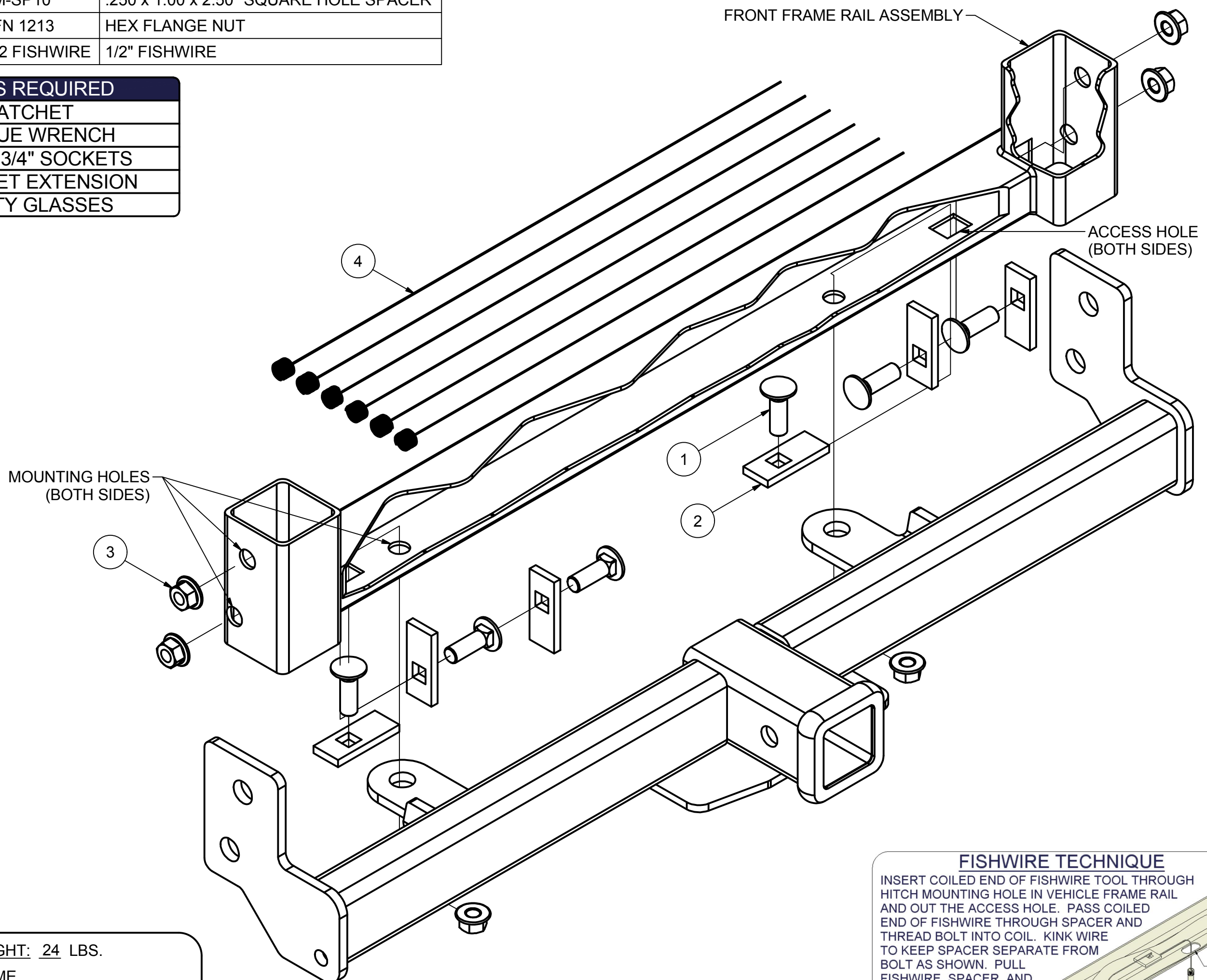

### FISHWIRE TECHNIQUE

INSERT COILED END OF FISHWIRE TOOL THROUGH HITCH MOUNTING HOLE IN VEHICLE FRAME RAIL AND OUT THE ACCESS HOLE. PASS COILED END OF FISHWIRE THROUGH SPACER AND THREAD BOLT INTO COIL. KINK WIRE TO KEEP SPACER SEPARATE FROM BOLT AS SHOWN. PULL FISHWIRE, SPACER, AND BOLT THROUGH FRAME AND OUT MOUNTING HOLE. USE FISHWIRE TO GUIDE HITCH DURING MOUNTING AND PREVENT LOSS OF BOLT / SPACER INSIDE FRAME RAIL.

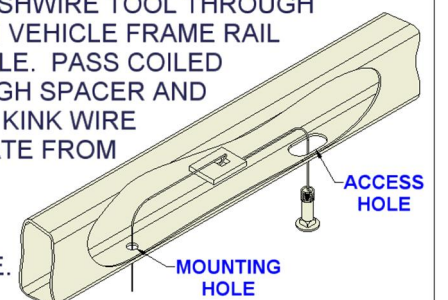

\*\*NOTE: SOME VEHICLES MAY FISHWIRE THROUGH END OF FRAME\*\*

HITCH WEIGHT: 24 LBS.

#### INSTALL TIME

PROFESSIONAL: 20 MINUTES

NOVICE (DIY): 40 MINUTES

#### INSTALL NOTES:

- NO DRILLING
- FISHWIRE HARDWARE

## INSTALLATION STEPS

1. Remove skid plate from vehicle using 15mm socket, removing (7) hex bolts. Return skid plate and hardware to owner.
2. Fishwire (3) CM-SP10 spacers and (3) 1/2" carriage bolts through access hole and out mounting holes on each side. (As shown in the Fishwire Technique Diagram)
3. Raise hitch into position and secure with (3) 1/2" flange nuts on each side.
4. Torque 1/2" hardware to 110 ft-lbs.

INSTALLATION COMPLETE

**PERIODICALLY CHECK THIS RECEIVER HITCH TO ENSURE THAT ALL FASTENERS ARE TIGHT AND THAT ALL STRUCTURAL COMPONENTS ARE SOUND.**

CURT Manufacturing LLC., warrants this product to be free of defects in material and/or workmanship at the time of retail purchase by the original purchaser. If the product is found to be defective, CURT Manufacturing LLC., may repair or replace the product, at their option, when the product is returned, prepaid, with proof of purchase. Alteration to, misuse of, or improper installation of this product voids the warranty. CURT Manufacturing LLC.'s liability is limited to repair or replacement of products found to be defective, and specifically excludes liability for incidental or consequential loss or damage.

This product complies with safety specifications and requirements for connecting devices and towing systems of the state of New York, V.E.S.C.Regulation V-5 and SAE J684.

**\*\*\*DO NOT EXCEED VEHICLE MANUFACTURER'S RECOMMENDED TOWING CAPACITY\*\*\*.**

### FRONT MOUNTED ACCESSORIES

1) Do not exceed front axle Gross Weight Rating (GAWR). Consult owners manual or specification plate located on driver's door frame. Measure gross front axle weight by placing front wheels of loaded vehicle on a scale.

**WARNING:** Exceeding GAWR may overload the front axle and/or suspension. This could result in **accident, property damage and personal injury.**

2) Reposition front mounted license plate if obstructed.

3) Do not obstruct vehicle lights.

4) Allow free air flow into grille opening.

5) Rear wheel traction may be reduced. This could effect handling. Reduce speed and drive with caution.

6) Accessories extend front of vehicle. This may reduce approach angle. Use caution when parking and maneuvering.

7) Do not obstruct driver view.

### VEHICLE RECOVERY AND WINCHING TIPS

1) Use OEM tow hooks, recovery eyes or a clevis mount for attachment of a tow strap or winch cable.

**WARNING: NEVER** use a ball and/or ball mount as an anchor point for tow strap or winch cable. Severe personal injury or death could result.

2) Observe winch manufacturer's recommendations, cautions and warnings.

3) Attach return cable to tow hook or recovery eye when using a snatch block (See figure 1).

**CAUTION:** Do not attach return cable to winch mount. This may overload winch mount and/or front mounted receiver.

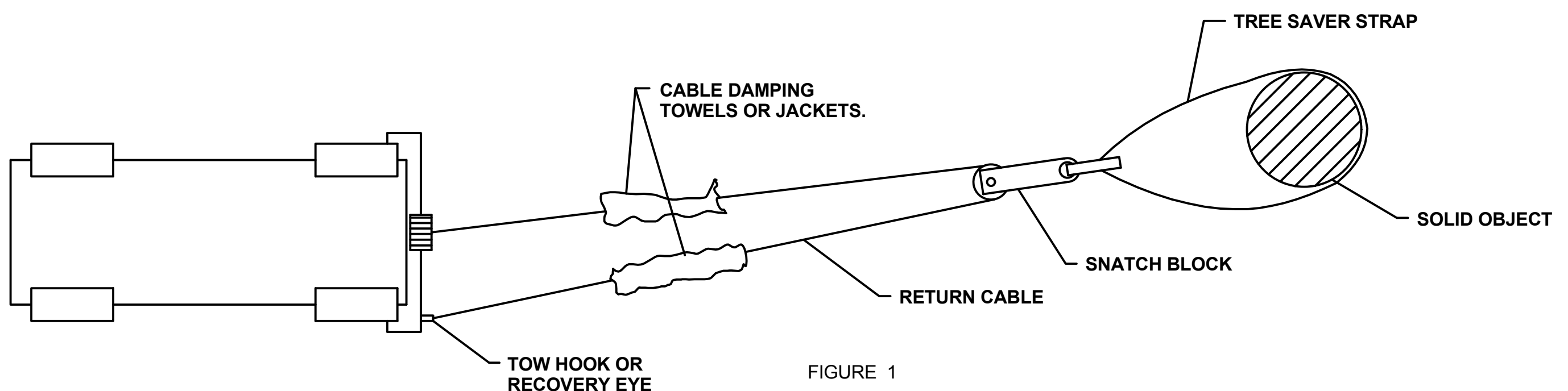

### RATING

For **Maximum** line pull rating, winch cable must not exceed:

- 15 degree angle up or down from horizontal (See Figure 2).
- 45 degree angle left or right from straight ahead (See Figure 3).

**CAUTION:** Exceeding the maximum line pull rating may over load winch, winch mount, and/or front mounted receiver.

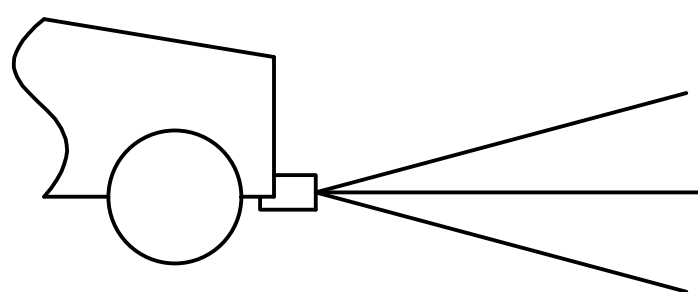

FIGURE 2

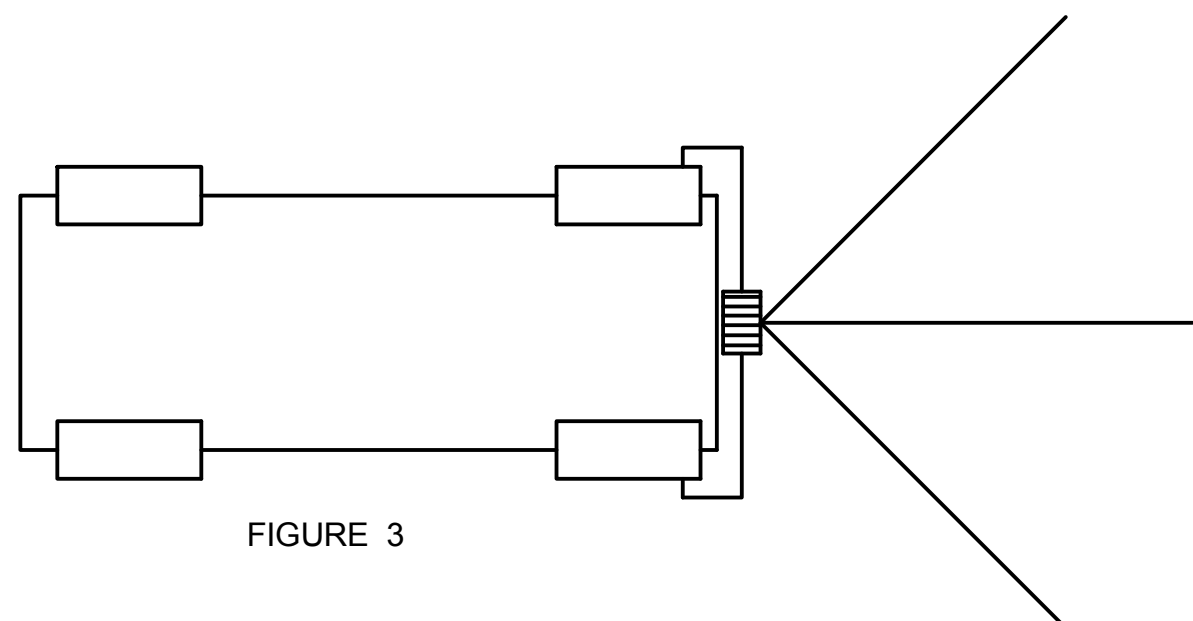

FIGURE 3

CURT Manufacturing LLC., warrants this product to be free of defects in material and/or workmanship at the time of retail purchase by the original purchaser. If the product is found to be defective, CURT Manufacturing LLC., may repair or replace the product, at their option, when the product is returned, prepaid, with proof of purchase. Alteration to, misuse of, or improper installation of this product voids the warranty. CURT Manufacturing LLC.'s liability is limited to repair or replacement of products found to be defective, and specifically excludes liability for incidental or consequential loss or damage.