



Safety glasses should be worn at all times while installing this product.

YEARS: 2017

MAKE: NISSAN

MODEL: ARMADA

STYLE: SUV

WARNING: NEVER EXCEED YOUR VEHICLE MANUFACTURER'S RECOMMENDED TOWING CAPACITY

WEIGHT CARRYING:
 TRAILER WEIGHT: 5,000 LBS.
 TONGUE WEIGHT: 500 LBS.

**GROSS LOAD CAPACITY WHEN USED AS A STRAIGHT LINE PULL:
 9,000 LBS MAX.**

PRO INSTALL TIME: 30 MIN.
NOVICE INSTALL TIME: 60 MIN.





IF YOU ARE HESITANT TO UNDERTAKE THIS TASK ON YOUR OWN, CONTACT AN AUTHORIZED CURT INSTALLER FOR ADDITIONAL ASSISTANCE.

INSTALLATION TIPS:

- BEFORE YOU BEGIN INSTALLATION, READ ALL INSTRUCTIONS THOROUGHLY.
- TO EASE INSTALLATION, 2 PEOPLE MAY BE REQUIRED.
- USING PROPER TOOLS WILL GREATLY IMPROVE THE QUALITY OF THE INSTALL AND REDUCE THE TIME REQUIRED.



INSTALLATION REQUIRES:

| | | |
|--|---|---|
|  3/4" 13mm 20mm SOCKET |  6" SOCKET EXTENSION |  RATCHET |
|  TORQUE WRENCH | | |
| | | |
| | | |

LEVEL OF DIFFICULTY: EASY

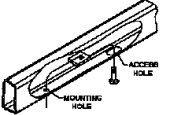
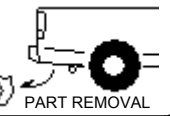
| <i>EASY</i> | <i>MODERATE</i> | <i>CHALLENGING</i> |
|---|---|--------------------|
|  | NO DRILLING REQUIRED | |
|  | FISHWIRE (4) CARRIAGE BOLTS AND SPACERS | |
|  | REMOVE TOW LOOP PERMANENTLY REMOVE SKID SHIELD TEMPORARILY | |
| | | |
| | | |

HITCH ILLUSTRATION:

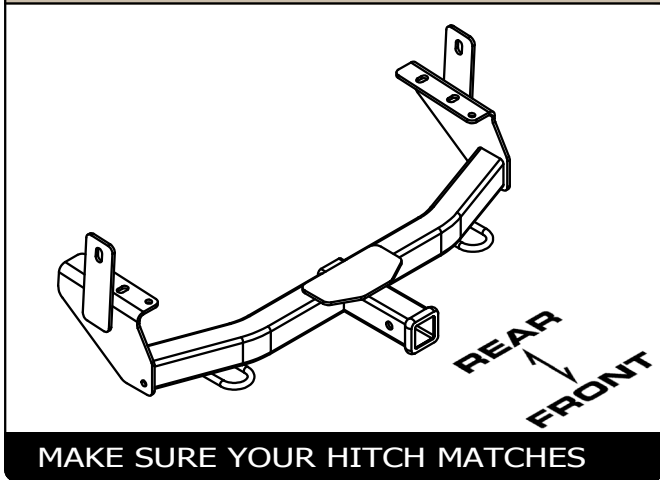

INSTALLATION WALKTHROUGH:

| Parts List | | | |
|------------|-----|---------------------|--|
| ITEM | QTY | PART NUMBER | DESCRIPTION |
| 1 | 4 | 1/2-13 x 1 1/2, GR8 | CARRIAGE BOLT |
| 2 | 4 | CM-SP6 | .250 x 1.00 x 3.00" SQUARE HOLE SPACER |
| 3 | 4 | 1_2 FISHWIRE | 1/2" FISHWIRE |
| 4 | 4 | HFN 1213, GR8 | HEX FLANGE NUT |
| 5 | 2 | 1/2 | CONICAL TOOTHED WASHER |
| 6 | 2 | M12-1.25 x 35mm | HEX BOLT |

REVERSE PULL FISHWIRE TECHNIQUE

ATTACH FISHWIRE TO CARRIAGE BOLT AND SLIDE SPACER ONTO FISHWIRE. PUSH THE BOLT THRU THE HOLE FOLLOWED BY THE SPACER (AS SHOWN). PULL BOLT BACK INTO POSITION, PROTRUDING FROM THE FRAME.

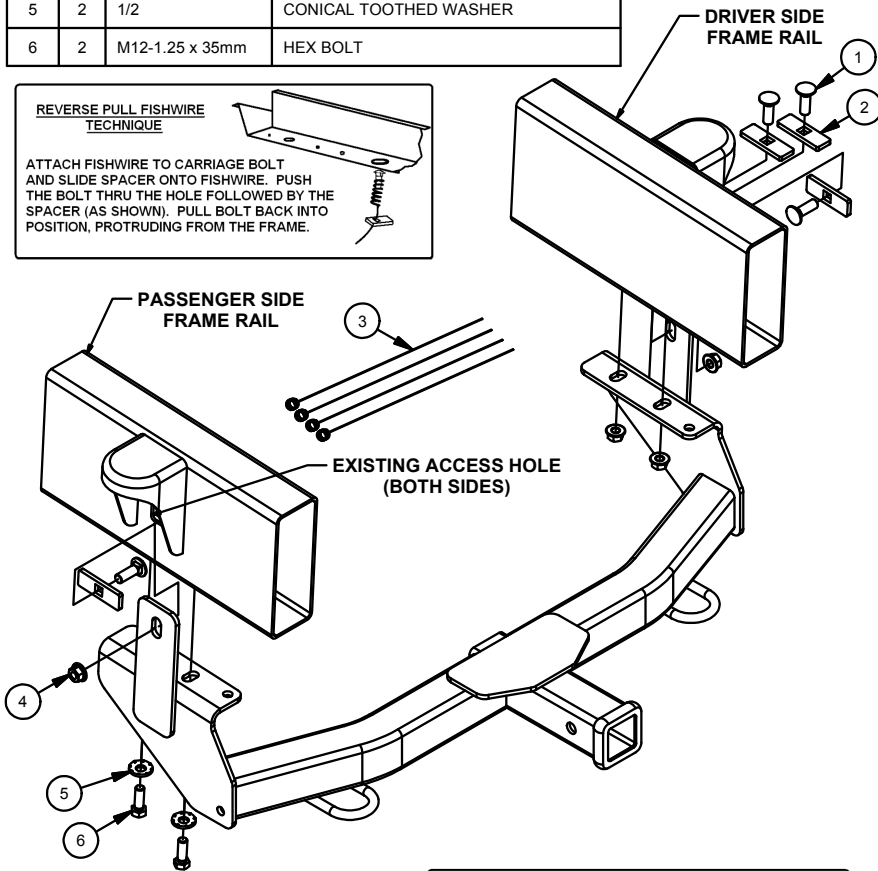
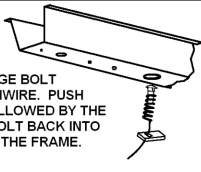

FISHWIRE TECHNIQUE

INSERT COILED END OF FISHWIRE TOOL THROUGH HITCH MOUNTING HOLE IN VEHICLE FRAME RAIL AND OUT THE ACCESS HOLE. PASS COILED END OF FISHWIRE THROUGH SPACER AND THREAD BOLT INTO COIL. KINK WIRE TO KEEP SPACER SEPERATE FROM BOLT AS SHOWN. PULL FISHWIRE, SPACER, AND BOLT THROUGH FRAME AND OUT MOUNTING HOLE. USE FISHWIRE TO GUIDE HITCH DURING MOUNTING AND PREVENT LOSS OF BOLT / SPACER INSIDE FRAME RAIL.

NOTE: SOME VEHICLES MAY FISHWIRE THROUGH END OF FRAME

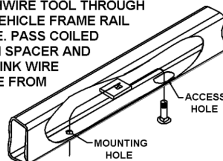

1. Remove skid shield by removing (4) 6mm bolts with a 13mm socket. Remove the tow loop on the passenger side by removing (2) 12mm bolts with a 20mm socket. Return the tow loop and its fasteners to the vehicle owner.

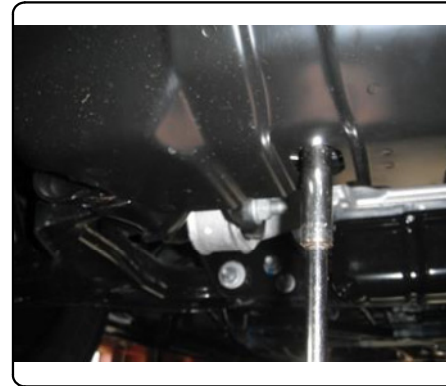

2. Fishwire (2) 1/2" carriage bolts and spacers into the lower mounting locations on the driver side frame rail.

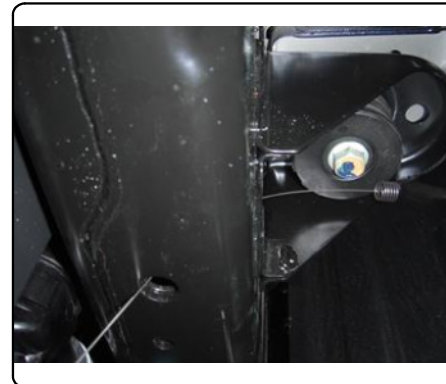

INSTALLATION WALKTHROUGH:

- Reverse fishwire the remaining (2) 1/2" carriage bolts and spacers into the access holes in the side of the frames. Keep the side mounting bolts and spacers in the frame rails and leave all fishwires attached until the hitch is in position.

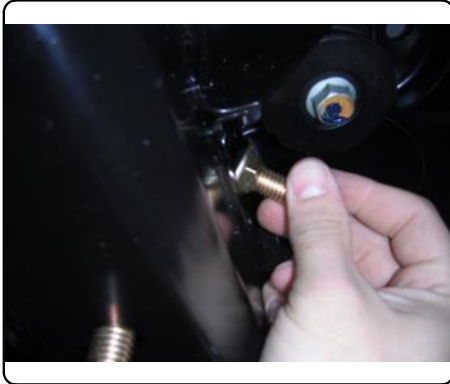

- Raise hitch into position and loosely install the (4) 1/2" hex flange nuts supplied. Loosely install the remaining (2) 12mm hex bolts and conical tooth washers supplied.

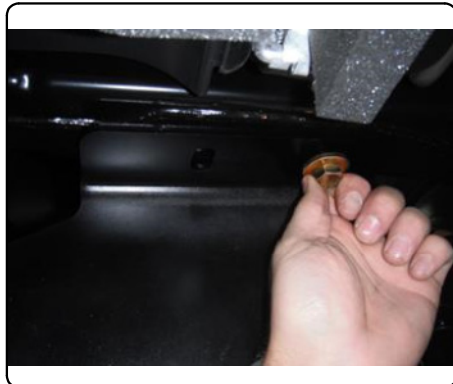

- Torque all 1/2" fasteners to 110 lb.-ft. and all 12mm fasteners to 86 lb.-ft.



- Reinstall the skid shield with the fasteners removed in step 1.

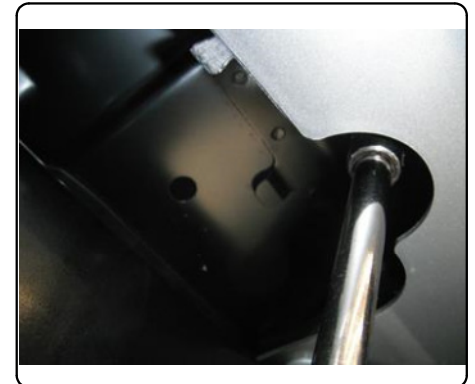

31081

NISSAN ARMADA

GROSS LOAD CAPACITY WHEN USED AS A WEIGHT CARRYING HITCH: 5,000 LBS. TRAILER WEIGHT & 500 LBS. TONGUE WEIGHT.
GROSS LOAD CAPACITY WHEN USED AS A STRAIGHT LINE PULL: 9,000 LBS. MAX. LINE PULL.



WARNING: * DO NOT EXCEED VEHICLE MANUFACTURER'S RECOMMENDED TOWING CAPACITY. *****



| Parts List | | | |
|------------|-----|---------------------|--|
| ITEM | QTY | PART NUMBER | DESCRIPTION |
| 1 | 2 | M12-1.25 x 35mm | HEX BOLT |
| 2 | 2 | 1/2 | CONICAL TOOTHED WASHER |
| 3 | 4 | CM-SP6 | .250 x 1.00 x 3.00" SQUARE HOLE SPACER |
| 4 | 4 | 1/2-13 x 1 1/2, GR8 | CARRIAGE BOLT |
| 5 | 4 | HFN 1213, GR8 | HEX FLANGE NUT |
| 6 | 4 | 1_2 FISHWIRE | 1/2" FISHWIRE |

| TOOLS REQUIRED |
|----------------------|
| 13mm and 20mm SOCKET |
| 3/4" SOCKET |
| 6" SOCKET EXTENSION |
| RATCHET |
| TORQUE WRENCH |

FISHWIRE TECHNIQUE

INSERT COILED END OF FISHWIRE TOOL THROUGH HITCH MOUNTING HOLE IN VEHICLE FRAME RAIL AND OUT THE ACCESS HOLE. PASS COILED END OF FISHWIRE THROUGH SPACER AND THREAD BOLT INTO COIL. KINK WIRE TO KEEP SPACER SEPARATE FROM BOLT AS SHOWN. PULL FISHWIRE, SPACER, AND BOLT THROUGH FRAME AND OUT MOUNTING HOLE. USE FISHWIRE TO GUIDE HITCH DURING MOUNTING AND PREVENT LOSS OF BOLT / SPACER INSIDE FRAME RAIL.

NOTE: SOME VEHICLES MAY FISHWIRE THROUGH END OF FRAME

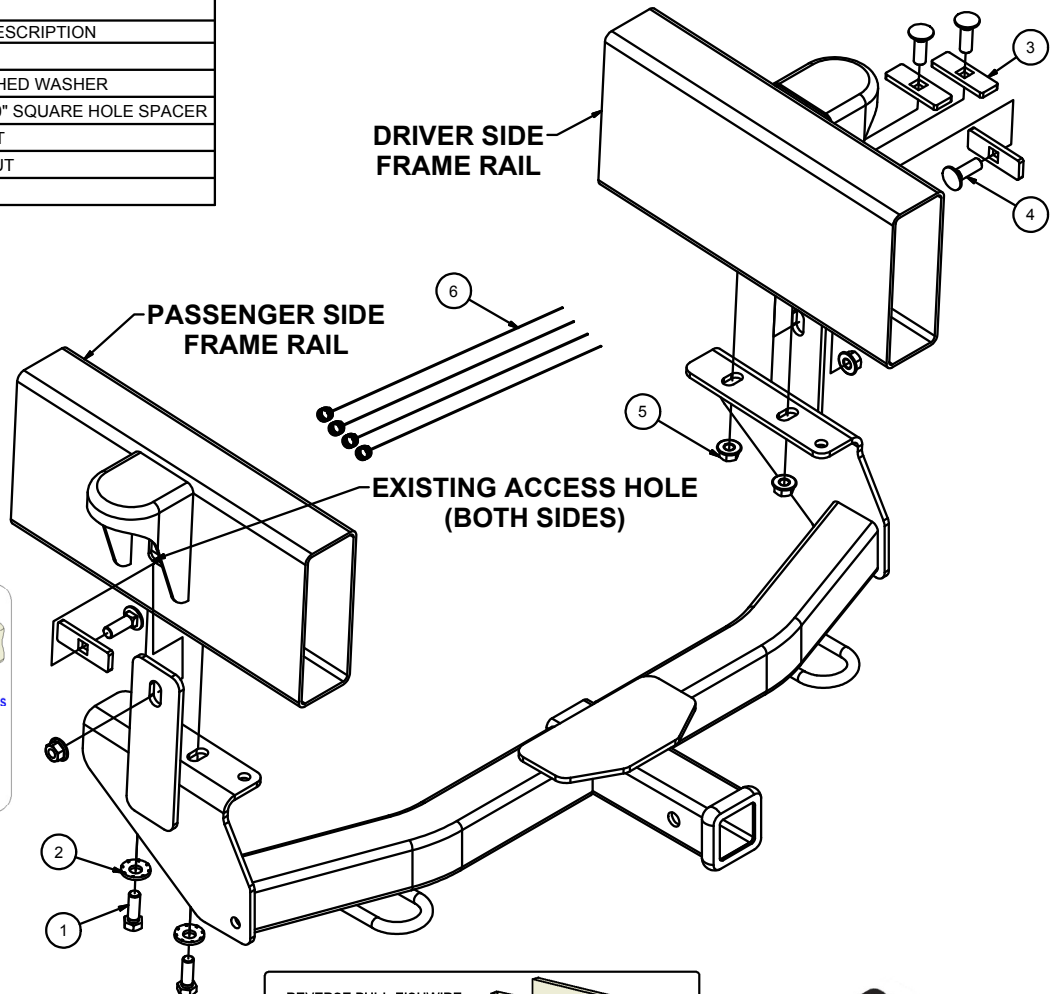

REVERSE PULL FISHWIRE TECHNIQUE

ATTACH FISHWIRE TO CARRIAGE BOLT AND SLIDE SPACER ONTO FISHWIRE. PUSH THE BOLT THRU THE HOLE FOLLOWED BY THE SPACER (AS SHOWN). PULL BOLT BACK INTO POSITION, PROTRUDING FROM THE FRAME.

REAR
↑
FRONT

HITCH WEIGHT: 40 LBS.

INSTALL TIME

PROFESSIONAL: 30 MINUTES

NOVICE (DIY): 60 MINUTES

INSTALL NOTES:

- NO DRILLING REQUIRED
- FISHWIRING REQUIRED
- REMOVE TOW LOOP AND SKID SHIELD

INSTALLATION STEPS

1. Remove skid shield by removing (4) 6mm bolts with a 13mm socket. Remove the tow loop on the passenger side by removing (2) 12mm bolts with a 20mm socket. Return the tow loop and its fasteners to the vehicle owner.
2. Fishwire (2) 1/2" carriage bolts and spacers into the lower mounting locations on the driver side frame rail.
3. Reverse fishwire the remaining (2) 1/2" carriage bolts and spacers into the access holes in the side of the frames. Keep the side mounting bolts and spacers in the frame rails and leave all fishwires attached until the hitch is in position.
4. Raise hitch into position and loosely install the (4) 1/2" hex flange nuts supplied. Loosely install the remaining (2) 12mm hex bolts and conical tooth washers supplied.
5. Torque all 1/2" fasteners to 110 lb.-ft. and all 12mm fasteners to 86 lb.-ft.
6. Reinstall the skid shield with the fasteners removed in step 1.

PERIODICALLY CHECK THIS RECEIVER HITCH TO ENSURE THAT ALL FASTENERS ARE TIGHT AND THAT ALL STRUCTURAL COMPONENTS ARE SOUND.

DO NOT EXCEED VEHICLE MANUFACTURER'S RECOMMENDED TOWING CAPACITY.

FRONT MOUNTED ACCESSORIES

1) Do not exceed front axle Gross Weight Rating (GAWR). Consult owners manual or specification plate located on driver's door frame. Measure gross front axle weight by placing front wheels of loaded vehicle on a scale.

WARNING: Exceeding GAWR may overload the front axle and/or suspension. This could result in **accident, property damage and personal injury.**

- 2) Reposition front mounted license plate if obstructed.
- 3) Do not obstruct vehicle lights.
- 4) Allow free air flow into grille opening.
- 5) Rear wheel traction may be reduced. This could effect handling. Reduce speed and drive with caution.
- 6) Accessories extend front of vehicle. This may reduce approach angle. Use caution when parking and maneuvering.
- 7) Do not obstruct driver view.

VEHICLE RECOVERY AND WINCHING TIPS

1) Use OEM tow hooks, recovery eyes or a clevis mount for attachment of a tow strap or winch cable.

WARNING: NEVER use a ball and/or ball mount as an anchor point for tow strap or winch cable. Severe personal injury or death could result.

- 2) Observe winch manufacturer's recommendations, cautions and warnings.
- 3) Attach return cable to tow hook or recovery eye when using a snatch block (See figure 1).

CAUTION: Do not attach return cable to winch mount. This may overload winch mount and/or front mounted receiver.

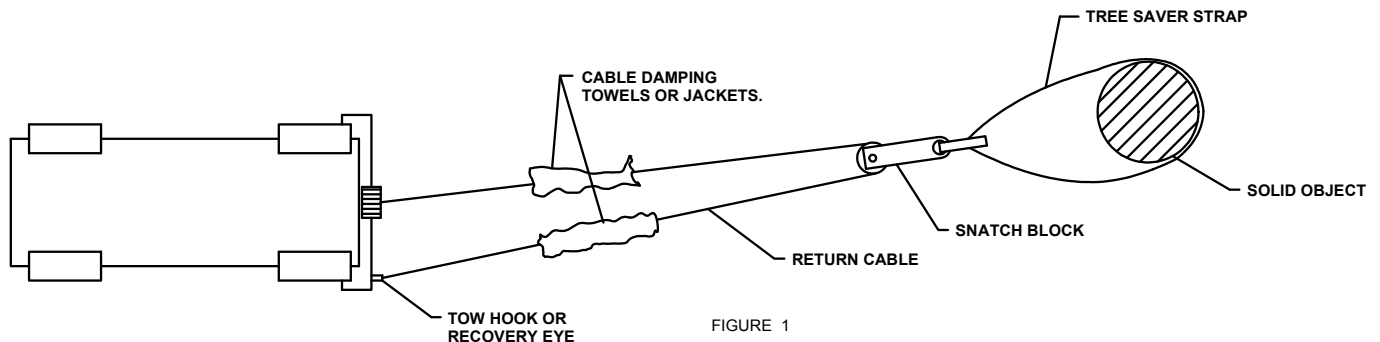

RATING

For **Maximum** line pull rating, winch cable must not exceed:

- 15 degree angle up or down from horizontal (See Figure 2).
- 45 degree angle left or right from straight ahead (See Figure 3).

CAUTION: Exceeding the maximum line pull rating may over load winch, winch mount, and/or front mounted receiver.

