

# INSTALLATION INSTRUCTIONS

**WARNING: NEVER EXCEED YOUR VEHICLE MANUFACTURER'S RECOMMENDED TOWING CAPACITY**

## TRUTRACK<sup>TM</sup> TRUNNION BAR WEIGHT DISTRIBUTION SYSTEM



### WEIGHT RATINGS

**CAUTION:** The tongue weight rating of the spring bars represents the capacity of a pair of bars, not an individual bar. Always use a pair of spring bars and be sure they are of the same weight rating.

Part#	Gross Trailer Weight	Tongue Weight
<b>Without Spring Bars</b>		
17501	Not to exceed 15,000 lbs.*	Not to exceed 1,500 lbs.*
<b>With Spring Bars</b>		
17501	10,000 - 15,000 lbs.	1,000 - 1,500 lbs.

\* When spring bars are not used, the weight rating is dependent upon the trailer ball manufacturer's weight ratings. Do not exceed the maximum weight rating of the trailer ball.

### MAINTENANCE

Keep the socket-mounted ends of the spring bars and the lock pins in the head assembly free from dirt and well lubricated. Excessive wear in this area may indicate an overload or inadequate lubrication.

Keep the head assembly exterior clean. Do not allow dirt or stones to lodge between the spring bars and the head.

Keep hitch parts painted to prevent rust and maintain good appearance. Do not paint over labels.

Keep lift brackets clean and lubricated to ensure ease of operation.

### WARNINGS

The loaded ball height should never be greater than the uncoupled ball height. Front wheel overload and loss of rear wheel traction can result and can lead to unstable handling. It can reduce braking ability and create a tendency to jackknife when turning and braking at the same time.

If the loaded trailer ball height is greater than the uncoupled height, reduce take-up on the spring bar, remeasure and adjust until the proper height is obtained.

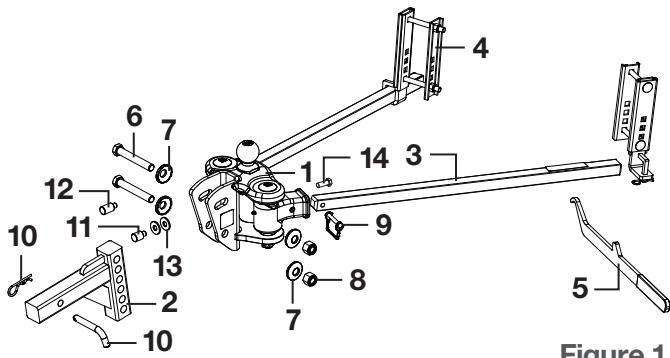

Figure 1

## PARTS LIST

Item#	Qty	Description
1	1	Hitch head
2	1	Adjustable shank bar
3	2	Spring trunnion bar
4	2	A-frame bracket
5	1	Snap-up handle
6	2	Hex bolt, 3/4" - 10 x 5" long
7	4	Conical washer, 3/4"
8	2	Nylock nut, 3/4" - 10
9	2	Wire lock lynch pin
10	1	Hitch pin & clip, 5/8"
11	1	Adjustment rod, short
12	1	Adjustment rod, long
13	2	Flat washer, 1/2"
14	1	Hex bolt, 5/8" - 11 x 1 1/2" long

## ASSEMBLY

### Measure trailer coupler height

Line up the tow vehicle and trailer on level pavement, in a straight position. Use the trailer tongue jack to level the trailer. Measure the distance from pavement to the top of the coupler socket and record here \_\_\_\_\_

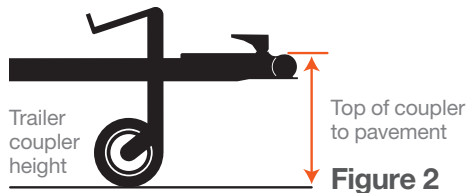

Figure 2

### Measure the tow vehicle

Pick reference points on the front and rear bumper of the towing vehicle. Measure and record height to pavement.

Front bumper to pavement \_\_\_\_\_

Rear bumper to pavement \_\_\_\_\_

For vehicles with air springs, air shocks or automatic leveling systems only, check the vehicle's owners manual or other instructions on these items. Unless otherwise indicated, air springs and air shocks should be deflated to their minimum recommended pressure before assembling and adjusting the weight distributing hitch.

### Determine the 'target' uncoupled ball height for the tow vehicle

Tow vehicle's uncoupled ball height will be set higher than the coupler height measured in Figure 2 to allow for vehicle squat when coupled to trailer.

For passenger cars, add 1/8" for each 100 lbs. of tongue weight. Record ball height \_\_\_\_\_

### Install shank, hitch head and ball

#### Step 1

Insert adjustable shank bar (#2) into receiver tube on tow vehicle and secure with hitch pin & clip (#10). **NOTE:** To obtain proper ball height on high ground clearance vehicles, shank may be inverted as shown in Figure 3. If shank is used in the inverted position, check for adequate ground clearance.

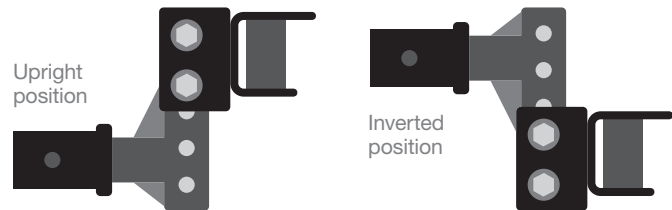

Figure 3

#### Step 2

Position head assembly (#1) on shank (#2). Slide head up or down to the nearest bolt hole alignment position which corresponds with the target ball height determined earlier. Mark the position on the shank. See Figure 4.

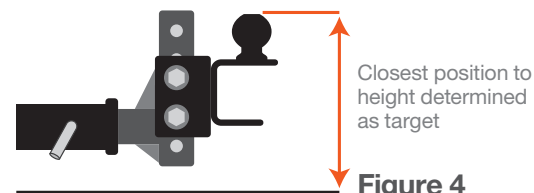

Figure 4

#### Step 3

Set the initial tilt position and loosely attach the hitch head (#1) to the shank (#2) in the position determined in Step 1.

#### Step 4

Install washers (#13) over short adjustment rod (#11).

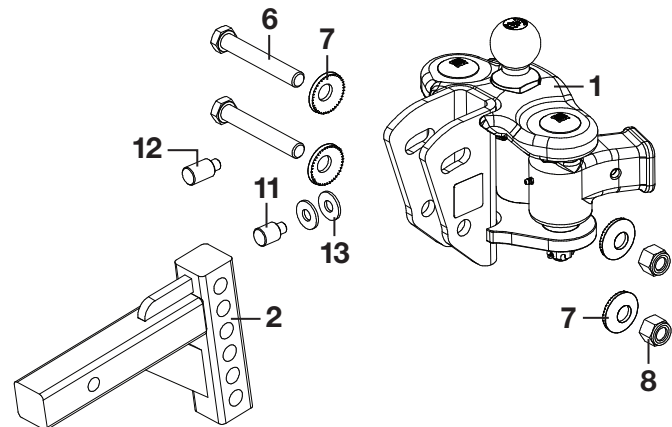

Figure 5

### Step 5

Install the head on the shank at marked position. Insert a 3/4" - 10 hex bolt (#6) through the 3/4" conical washer (#7) and then through the lower hole in the head channel. Rotate the head forward as far as it will go. The ball should be vertical or tilted slightly back. If it is not, remove the short adjustment rod (#11) and replace it with the long adjustment rod (#12). You can also change the number of washers on the rod and re-assemble. Install the remaining 3/4" - 10 bolt (#6) with 3/4" conical washer (#7) through the upper slotted hole. Install a second 3/4" conical washer (#7) on both bolts. Start 3/4" - 10 (#8) nylock nuts and tighten until the head unit is snug and does not tilt on its own. Install 5/8" hex bolt (#14) and tighten until head unit is snug.

### Step 6

Tighten 3/4" - 10 bolts (#6) just enough to hold the spacers (#11 or #12) into the hitch head (#1). These bolts will be tightened after the correct tilt setting has been determined.

### Step 7

Place head assembly back into hitch assembly on towing vehicle.

## Install the spring bars

Secure the two spring bars (#3) with the supplied pins (#9).

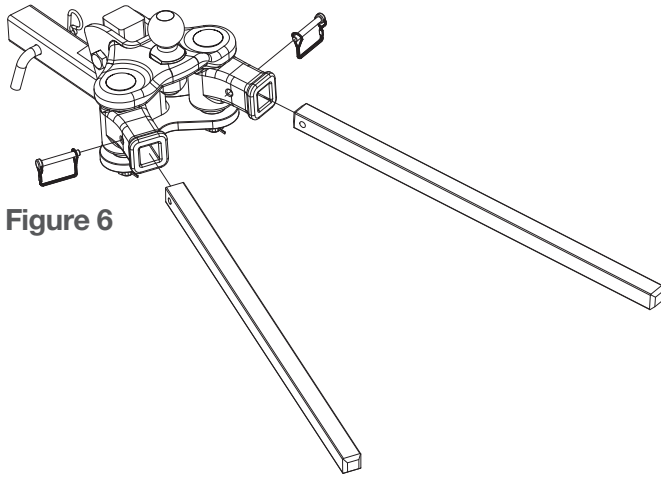

Figure 6

## Attaching the trailer to the ball

Using the trailer tongue jack, lower coupler onto the trailer ball and close coupler latch. Do not retract jack fully at this time. Allow the jack to support some of the tongue weight.

Raise the front of the trailer and back of the tow vehicle approximately 3" with tongue jack. This will allow easier installation of the spring bars onto the support brackets.

## Installing the spring bar support brackets

### Step 1

Mark the position of the support brackets by making a center line on the trailer A-frame 4" in from the end of the spring bars.

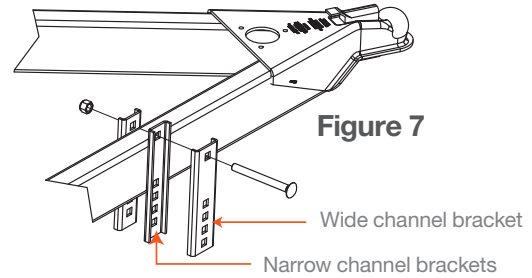

Figure 7

### Step 2

Place a carriage bolt through the top hole on all three channel brackets, spin the nylock nut loosely onto the bolt, and hang the assembly over the trailer A-frame on the center line from Step 1.

**NOTE:** The wide channel bracket should be installed over the narrow channel as detailed in Figure 7.

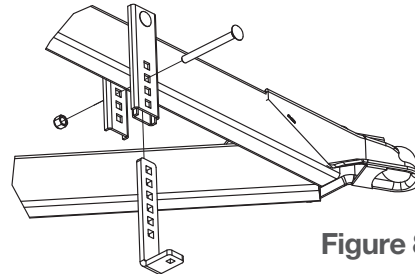

Figure 8

### Step 3

Slide the L-support in between the two captive channel brackets as shown above. Set the bracket height closest to the spring bar position set with the jack earlier. Install the second carriage bolt in the first hole directly below the trailer A-frame.

### Step 4

With the L-bracket installed, tighten both nylock nuts (#8) to 25 ft. lbs.

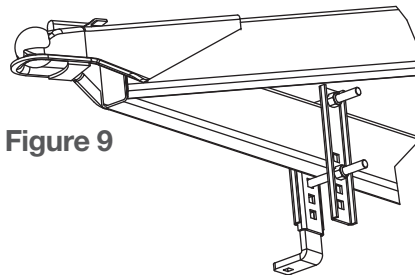

Figure 9

### Step 5

Repeat Steps 1 through 4 with the second support bracket on the opposite side of the trailer A-frame.

**WARNING:** Keep clear of the pivot path of all moving parts when there is tension on the spring bar. Maintain control of the lift handle at all times when raising or lowering the spring bar. Be sure that the locking clip and hair pin is in place once the spring bar is in position.

## To raise the spring bar

### Step 1

Pull the spring bar out from the A-frame and hook the lift bar into the L-bracket as shown below.

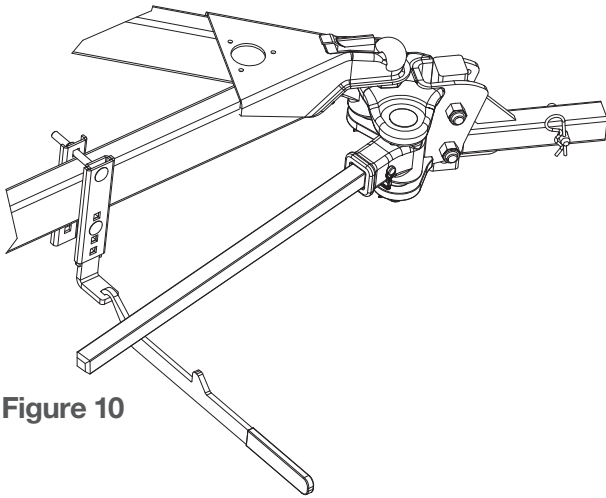

Figure 10

### Step 2

Pry the spring bar onto the L-bracket by rotating the lift bar to vertical.

### Step 3

With the spring bar supported by the L-bracket, remove the lift handle. Secure the spring bar by installing the retainer clip and cotter pin as shown below.

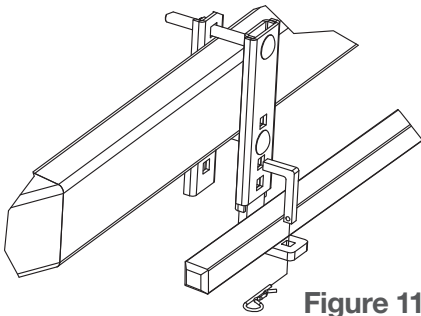

Figure 11

## Check vehicle height and adjust spring bars if necessary

With the spring bars secured, lower the jack to apply load to the hitch. The vehicle should settle evenly. Remeasure the front and rear bumper reference points. If the front has settled much more than the rear, lower the L-brackets to reduce the load on the spring bars. The spring bars should be nearly horizontal when correct height is achieved.

## Tighten head fasteners

After the correct tilt position has been determined and the tow vehicle is sitting level, the 3/4" bolts must be torqued.

Tighten 3/4" bolts and locknuts to 200 ft. lbs. Failure to tighten bolts may result in a complete system failure.

## Check all connections before towing

### Check the following:

- Pin & clip securing shank to receiver
- Head to shank fasteners
- Trailer ball nut
- Coupler latch
- Spring bar support brackets
- Safety chains
- Lights and turn signals
- Braking system, including breakaway switch

## To lower the spring bar

### Step 1

Remove the weight from the spring bars by using the trailer jack to lift the front of the trailer and rear of the tow vehicle.

### Step 2

With tension removed from the spring bars, carefully remove the cotter pin & clip.

### Step 3

With the spring bar clip removed, use the lift bar as a lever to pry the spring bar off of the L-bracket.

## Maintenance

Apply grease to the following locations prior to each use to ensure quiet and trouble free operation.

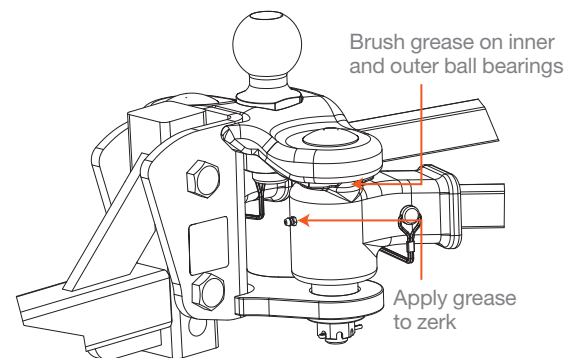

# TOWING TIPS

## Driving a tow vehicle

Good habits for normal driving need extra emphasis when towing a trailer. The additional weight of the trailer affects acceleration and braking. Extra time should be allowed for passing, stopping and changing lanes. Signal well in advance of a maneuver to let other drivers know your intentions. Severe bumps and badly undulating roads can damage your towing vehicle, hitch and trailer, and should be negotiated at a slow, steady speed. If any part of your towing system bottoms out or if you suspect damage may have occurred in any way, pull over and make a thorough inspection. Correct any problems before resuming travel.

## Check your equipment

Periodically check the condition of all your towing equipment and keep in top condition.

## Trailer loading

Proper trailer loading is very important. Heavy items should be placed close to the floor near the trailer axle center line. The load should be balanced side to side and firmly secured in the trailer to prevent shifting. Tongue weight should be 10-15% or the gross trailer weight for most trailers. Too low a tongue weight often produces tendency to sway.

## Check all trailer to towing vehicle connections for security and operation

Surge brake actuators not designed for use with a weight distributing hitch may bind and not operate freely. Check surge brake operating instructions for specific requirements regarding their use with weight distributing hitches.

## Remove hitch when not towing

Remove weight distribution hitch from the trailer hitch on towing vehicle when not towing a trailer to reduce chances of striking weight distribution hitch on the driveway or other objects. This also reduces the chance of parts being stolen.

## Towing vehicle and trailer manufacturer's recommendations

Review the owner's manual for your towing vehicle and trailer for specific recommendations, capacities and requirements.

## Passengers in trailers

Trailers should not be occupied while being towed. Most states enforce this regulation.

## Trailer lights, turn signals and electric brakes

Always hook up all of the trailer lights, electric brakes and break-away switch connections whenever trailer is being towed.

## Tire inflation

Unless specified by the towing vehicle or trailer manufacturer, tires should be inflated to their maximum recommended pressure.

## At the beginning of every tow day

Clean ball and coupler socket. Coat ball lightly with grease.

Check to see that all trailer balls are properly tightened and that the locking pins in the lift brackets are securely in place. Also, check that the hitch pin is in place and secure.

Check to see that all electrical hook-ups are in working order and that the security chains are securely connected.

## NOTES

Some states require a clear view of license plates. Remove trailer ball when not in use if it restricts view.

This product complies with regulation V-5, C.S.A. Standard D-264 and safety requirements for connecting devices and towing systems of the State of New York.