

# INSTALLATION MANUAL

16315

This is the second of two manuals required to complete this installation. The first manual is included with your mounting system.

## Level of Difficulty

Moderate

## Weight Capacity

Gross trailer weight (GTW)	30,000 lbs.
Vertical load	7,500 lbs.

## Parts List

Item	Qty	Description
1	1	Main body / Head assembly
2	1	Handle assembly
3	1	Handle lock bar
4	2	Button head cap screw, M8 - 1.25" x 30
5	2	Lock washer, M8
6	1	Latch spring
7	4	Hex bolt, M14
8	4	Lock washer, M14
9	4	Flat washer, M14
10	4	Nylock nut, M14
11	4	Base rail mounting clip
12	4	Base rail mounting pin, 1/2"

## Tools Required

Ratchet	Torque wrench
Socket set	--

## Torque Specifications

M8 bolt	16 ft.-lbs.
M14 bolt	100 ft.-lbs.
Use above torque setting unless otherwise noted	

## ⚠ DANGER ZONE PRECAUTIONS

Block all trailer tires in front and behind with appropriate wheel chocks. Do not substitute objects such as, but not limited to: stones, wood blocks, etc. Front trailer lifting jacks must be supporting the trailer and resting on a firm and level surface.

Towing vehicle must be stationary with automatic transmission in park (manual in neutral), emergency brake applied and engine off.

## ⚠ WARNING

Fully instruct and demonstrate the operation of this 5th wheel hitch to the end user. Include the importance of observing all warnings contained herein, including warning labels on 5th wheel hitch main body. Provide this manual in its entirety to the end user. Serious injury or death may result if the warnings above are not observed.

Do not expose hands, body parts or clothing between the truck and trailer or the truck's bed sides and trailer. If you must place any part of your body under trailer or between truck and trailer, you must:

1. Block all trailer tires with wheel chocks.
2. Make sure trailer landing gear / jacks are resting on a firm, level surface.
3. Towing vehicle must be stationary with auto transmission in park (manual in neutral), emergency brake applied and engine off.

Never exceed the towing capacity (trailer and contents combined) of any towing system component or your vehicle.

Improperly coupled trailers can separate or drop without notice, causing serious injury or death. To reduce the chance of serious injury or death:

Never attempt to couple trailer without reading and following all instructions thoroughly.

Always follow operating instructions to secure trailer to tow vehicle. Make sure the hitch is secure before towing.

Prior to towing, ensure all components and hardware are structurally sound and secure.

Always chock the trailer to prevent movement while coupling the hitch.

Always ensure lynch pins are installed through handle and center pivot pin before towing.

Always keep hands clear of the 5th wheel jaws when operating the handle.

Always perform a pull test prior to towing. See 'pull test' later in this instruction manual.

Never position anyone under the trailer's kingpin area during coupling and uncoupling.

## Product Photo

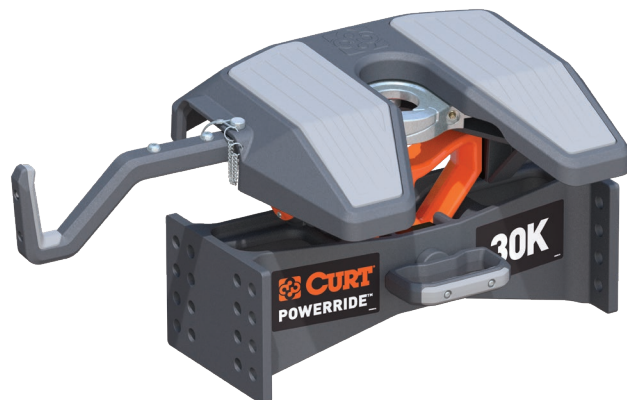

## NOTICE

Before you begin installation, read all instructions thoroughly.

Proper tools will improve the quality of installation and reduce the time required.

Periodic inspection of your product should be performed to ensure all hardware and / or components remain secure.

To help prevent damage to the product or vehicle, refer to the specified torque specifications when securing hardware during the installation process.

# ASSEMBLY

## Parts List

Item	Qty	Description
1	1	Main body / Head assembly
2	1	Handle assembly
3	1	Handle lock bar
4	2	Button head cap screw, M8 - 1.25" x 30
5	2	Lock washer, M8
6	1	Latch spring
7	4	Hex bolt, M14
8	4	Lock washer, M14
9	4	Flat washer, M14
10	4	Nylock nut, M14
11	4	Base rail mounting clip
12	4	Base rail mounting pin, 1/2"

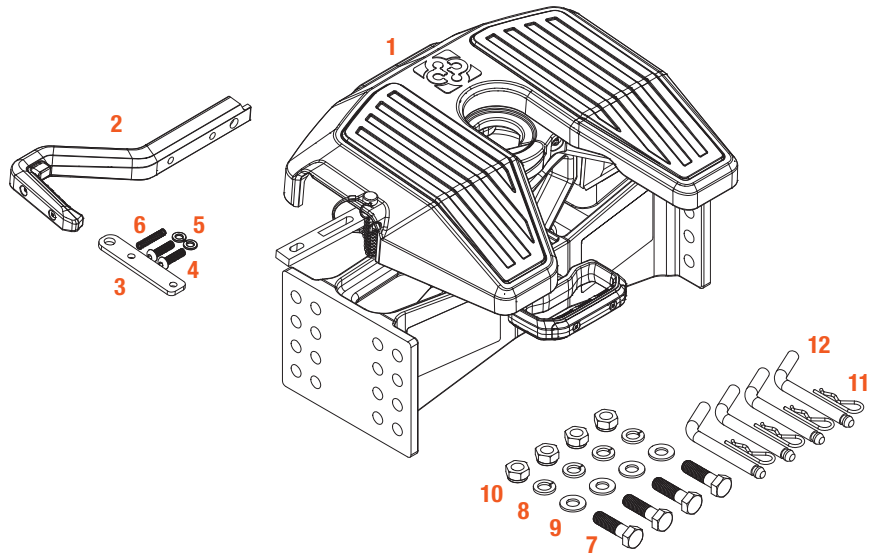

# CALCULATING HEIGHT

## Before you begin

Assembly includes measuring the height requirement for the 5th wheel head in relation to the trailer ride height at the kingpin box and skid plate. Ideally, the trailer should ride as near to level as possible.

The 5th wheel is adjustable from the truck bed to the top of its skid plate. Adjustment is attained by adjusting the main body up or down, in relation to the mounting system, in 1-1/4" increments (typical clearance between the truck bed rails and the trailer should be a minimum of 5-1/2"). Follow the next steps to measure.

## Step 1

With the trailer on a firm and level surface, set chock blocks in front of and behind the tires. (Do not substitute wood blocks, rocks, etc. for chock blocks.) Extend front trailer lifting jacks, adjust as required to set trailer at or near level.

## Step 2

Measure from the ground to under the trailer's kingpin box skid plate or lube plate, if used. This will be the portion in contact with the 5th wheel's skid plate once coupled.

## Step 3

Measure from the ground to the surface of the truck bed. Subtract the measurement taken in Step 2 from Step 1. This value will be near the height requirement for the 5th wheel.

# HANDLE ASSEMBLY

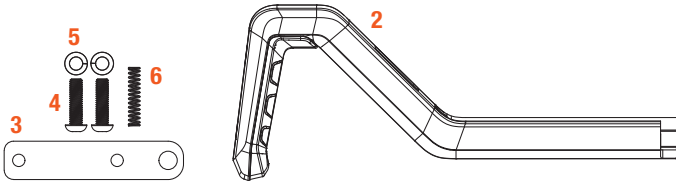

## Parts List

Item	Qty	Description
2	1	Handle assembly
3	1	Handle lock bar
4	2	Button head cap screw, M8 - 1.25" x 30
5	2	Lock washer, M8
6	1	Latch spring

## Step 1

Locate the provided handle assembly and hardware pack.

### **WARNING**

The jaws on the 5th wheel head are spring loaded. The jaws will open rapidly when the safety pin is removed and the handle is moved to the unlock position. Keep hands clear of the jaws at all time.

Place the head on a flat surface upside down and slide the handle assembly (#2) over the end of the handle mount bar on the 5th wheel head.

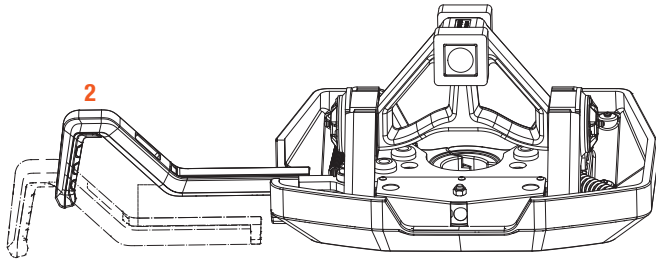

## Step 2

Insert the latch spring (#6) into the slot on the handle mount bar and compress slightly to allow the first M8 cap screw (#4) and lock washer (#5) to be lifted into position behind the spring.

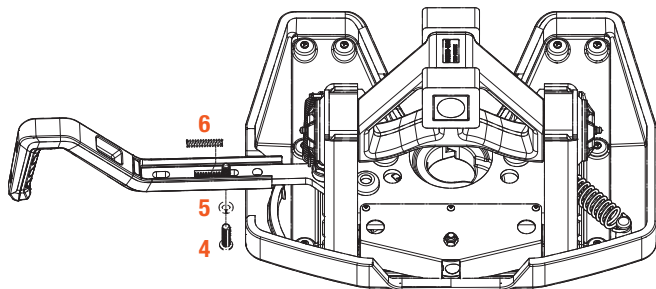

## Step 3

With the first M8 cap screw (#4) in place behind the latch spring, align with the threaded hole on the handle lock bar (#3) and finger tighten. Pull back slightly on the lock bar to further compress the spring and align the second hole with the small slot in the handle mount bar on the head.

Install the second M8 cap screw (#4) and lock washer (#5) through the handle assembly (#2) and into the second threaded hole on the lock bar (#3)

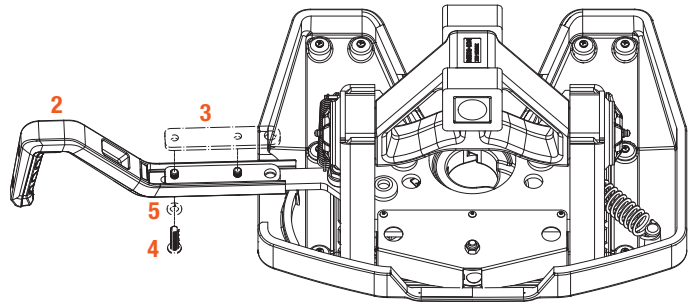

## Step 4

With the handle and latch plate loosely installed over the handle mounting bar on the head, rotate the head to the vertical position and torque the M8 bolts to 16 ft-lbs.

Complete the handle installation by inserting the safety lynch pin, locking the handle in the tow position.

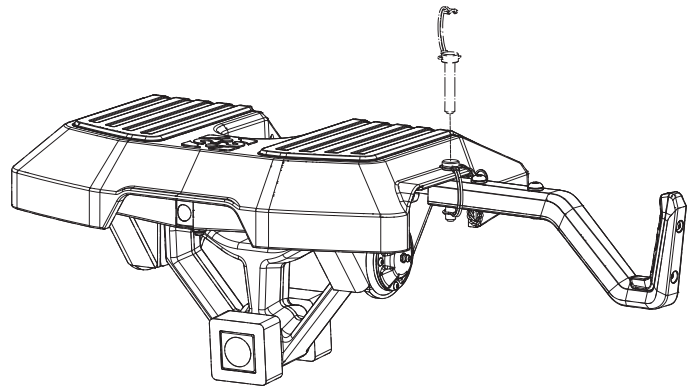

# COUPLING & LOCKING

Locked Handle  
GREEN indicator (circle)

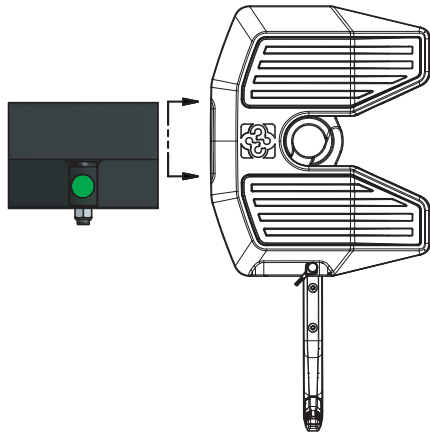

Unlocked Handle  
RED indicator (octagon)

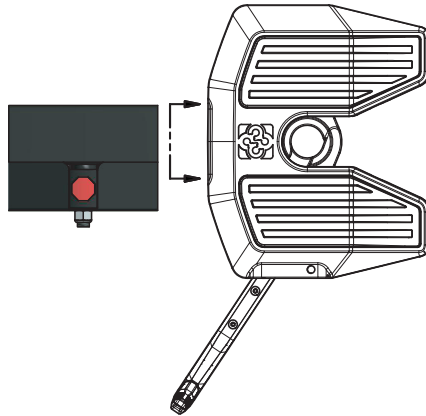

Coupled Handle  
YELLOW indicator (triangle)

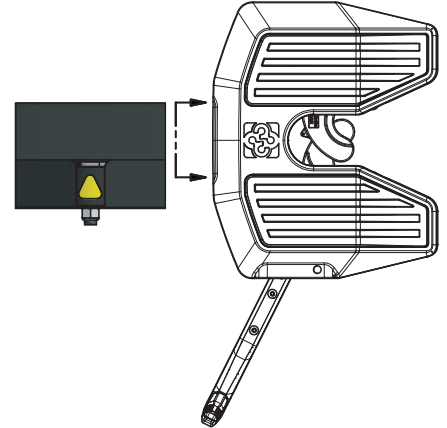

## Preparing the vehicle and trailer to couple

It is advised to perform trailer connections to the 5th wheel on a firm and level surface. Multiple wheel chocks should be used in front of and behind the trailer tires. Do not substitute objects such as, but not limited to: stones, wood blocks, etc.

Open or remove the tailgate as required to safely back the tow vehicle under the trailer and center the trailer kingpin with the opening on the hitch head. Do not engage the kingpin into 5th wheel at this time. Stop the tow vehicle when the trailer's skid plate is approximately 4" from the 5th wheel's skid plate.

Set automatic transmissions to park and activate the emergency brake. Set manual transmissions to neutral and activate the emergency brake.

Adjust the front trailer lifting jacks so the trailer's kingpin skid plate is approximately 1/2" below the top surface of the 5th wheel's skid plate lead-in ramp. See the diagram below for proper height setup prior to coupling.

**Note:** Trailer height setup is critical to allow the 5th wheel jaws to engage the kingpin and lock properly. Never attempt to lower the trailer's kingpin into the 5th wheel.

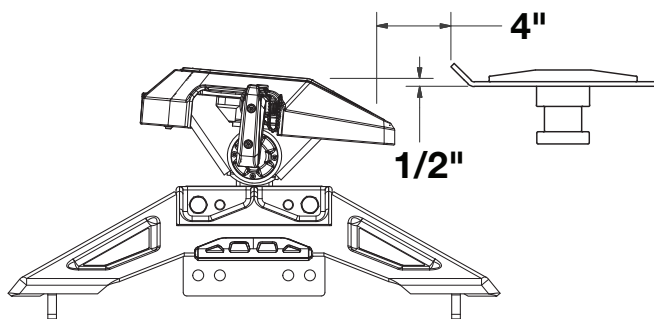

## Preparing the 5th wheel to couple

If the yellow indicator is visible, visually check that the jaws are open as illustrated in the 'COUPLED HANDLE' diagram above. If the jaw's are open and the handle is in the unlocked position, the 5th wheel is ready to couple. Skip to the 'Coupling' section on next page.

If the green indicator is visible and the jaw's are closed, they must be unlocked prior to use. The 'LOCKED HANDLE' diagram illustrates the jaws and handle in the closed and locked position.

Remove the safety latch pin from the 5th wheel's handle. Open the jaws by pulling handle out about 1/2" and then swinging it back toward the front of the tow vehicle. The handle will latch in the unlocked position and the yellow indicator will be visible from the tow vehicle cab.

If the 5th wheel handle will not latch in the unlocked position, or the red indicator is visible, go to the troubleshooting section to resolve the issue before attempting to couple your trailer.

### ⚠ WARNING

Attempting to couple your 5th wheel in any configuration other than the yellow couple position may result in damage to you trailer or 5th wheel. Always ensure the jaws are open and unobstructed prior to coupling to your trailer's kingpin.

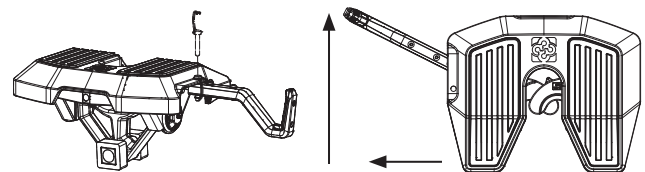

# COUPLING & LOCKING (CONT)

## Preparation troubleshooting

### ⚠️ WARNING - RED INDICATOR WITH JAWS OPEN - DO NOT TOW

Do not tow in this configuration. The jaws will close, but will not lock. Follow the steps below to correct the issue and prepare for coupling.

The red indicator signifies that the jaws are unlocked and the operating handle is latched in the unlock position (see 'RED HANDLE' diagram on the previous page). The red indicator will remain visible if the jaws are unable to fully open and reset the operating handle to the yellow couple position. Follow the steps below to attempt to reset the operating handle to the couple position.

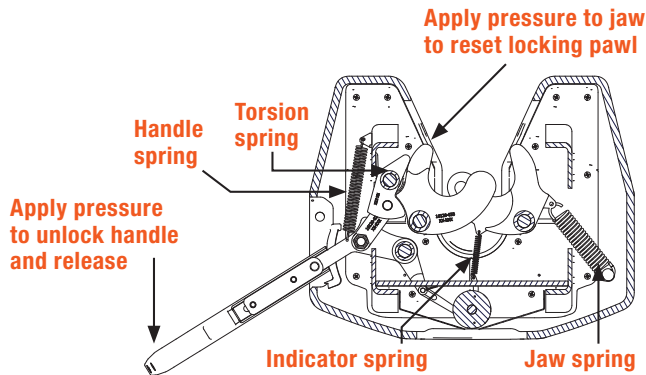

## Step 1

Check for any signs of damage to the locking mechanism. Ensure the jaws are open and the indicator, jaw, handle and torsion springs are all attached and undamaged. If any of the springs are missing or damaged, do not attempt to use the hitch until it has been repaired.

## Step 2

Ensure the locking mechanism is free of excessive dirt, rust, grease, snow, ice or other foreign material preventing it from cycling properly. Clean excessive dirt, snow or ice with warm soap water. Lightly lubricate exposed surfaces with a rust inhibitor to restore proper operation. Components with excessive amounts of rust may require replacement to restore proper functionality.

## Step 3

If cycling the handle is unsuccessful, apply pressure to the front of the jaw to manually reset the locking pawl. If the handle drops to the couple position and the indicator turns yellow, you are ready to couple.

## Step 4

If all components are undamaged and can freely move, apply pressure to the operating handle, as if unlocking, and release. If the handle drops back to the couple position and the indicator turns yellow, you are ready to couple.

## Before you couple

Your PowerRide™ is supplied with an integrated wear plate that eliminates the need for grease. To extend the life of the wear plates on the hitch, the system may also be used with a 3/16" lube plate attached to the trailer kingpin. If the integrated wear plates supplied with the hitch have worn to the point the lines are no longer visible they should be replaced. Never operate your 5th wheel without the integrated lube plates installed.

### ⚠️ WARNING

Never position yourself or others under the trailer's kingpin area (danger zone) during coupling and uncoupling. If for any reason, you must position any part of your body under the trailer or between the truck and trailer or between the trailer kingpin and 5th wheel hitch, you must follow the steps in the 'Danger Zone Precautions' on page 1.

## Coupling

Back-up the towing vehicle while remaining centered and aligned to trailer's kingpin. The trailer's kingpin skid plate will compress the towing vehicle's suspension and ramp up onto the 5th wheel skid plate. Refer to the 'HANDLE' diagrams on the previous page while observing the following:

- Trailer kingpin fully seats into opening on the 5th wheel head
- Yellow indicator will change to green indicator (when viewing from cab)
- Operating handle will swing rearward toward the trailer to the locked position

Visually confirm the trailer's skid plate is resting completely on the head of the 5th wheel. Also confirm the jaws are indeed locked around the trailer's kingpin. A gap may indicate the kingpin is not engaged into jaws properly or has high-sided and is resting on top of the jaw.

After visually confirming the jaws are properly engaged and locked, insert the safety pin through the locking handle to ensure it cannot be unlocked while towing.

### ⚠️ WARNING

Never tow without visually ensuring the kingpin is properly coupled and the safety pin has been installed. This will ensure the handle cannot be unintentionally unlocked.

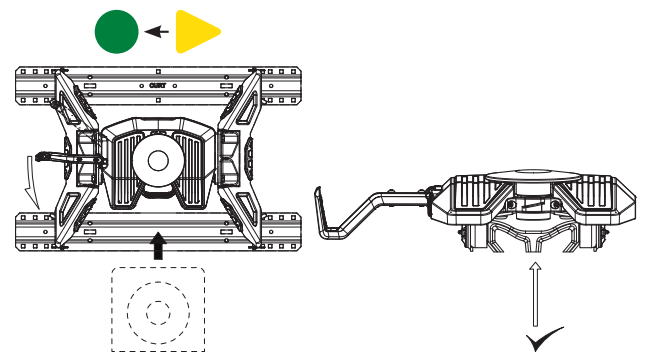

If the kingpin is resting on top of the jaws, immediately lower the trailer jacks to lift the kingpin off the jaws. Inspect the 5th wheel for damage that may have resulted from the improper coupling attempt. Under no circumstances should the 5th wheel unit be used if damage exists. If no damage exists, review coupling instructions and repeat procedure.

# COUPLING & LOCKING (CONT)

## Pull test

After coupling and prior to removing trailer wheel blocks and / or raising front trailer jacks, you must do the following.

Set towing vehicle in a forward gear and lightly tug on the trailer to ensure that 100% coupling has taken place. If resistance is felt, release forward pressure, set vehicle to park (if equipped with an automatic transmission) and activate the emergency brake. Place in neutral if equipped with a standard transmission and activate emergency brake.

If resistance is not felt, trailer may not be coupled correctly. Do not continue applying forward pressure, immediately stop and back towing vehicle into original position. Do not allow the truck and trailer to separate. Separation can cause damage to the towing vehicle, 5th wheel hitch and / or trailer. Serious injury or death may result if all warnings are not observed.

Review coupling instructions, apply corrective action and repeat coupling steps.

## Preparing to tow

Confirm handle safety latch pin has been installed.

Attach electrical harnesses.

Attach lanyard and insert electric brake break-away plunger. If hydraulic surge brakes are present, attach lanyard from the surge brake assembly as required.

Fully retract front trailer lifting jacks.

Close truck tailgate or reinstall tailgate as required.

Remove tire chock blocks.

Check running lights, directional signals and brake lights for proper operation.

Pull forward a few feet and apply brakes to check that trailer brakes are activating. Adjust the electric brake controller if necessary.

# UNCOUPLING & RESETTING

## Step 1

Park on a firm and level surface. Set automatic transmission vehicles to park and activate emergency brake. Set standard transmission vehicles to neutral and activate emergency brake.



Chock the trailer wheels. Multiple wheel chocks should be used, both in front and behind the tires. Do not substitute objects such as stones, wood blocks, etc.



Disconnect all harnesses, lanyards, safety devices, etc. as required to separate the trailer from the tow vehicle. Lower or remove truck tailgate as required.



Begin extending the front trailer lifting jacks. The lifting jacks should be extended just enough to remove the weight of the trailer from the 5th wheel skid plate.

**Note:** Creating a gap between the trailer skid plate and the 5th wheel skid plate is not necessary or recommended. If a gap is present, it should be minimal and no more than 1/16". Excessive gap while coupled can damage internal components of the 5th wheel hitch as well as components of your trailer.

## Step 2

With the trailer jacks down and wheels chocked, reduce any remaining load on the jaws and kingpin by backing the tow vehicle up slightly and pushing the kingpin completely into the opening on the 5th wheel head. Hold the position by applying your vehicle's parking brake before putting the vehicle in park and releasing the standard brake.



**BRAKE**



## Step 3

Remove the safety lynch pin from the handle of the 5th wheel. Unlock the jaws by pulling the locking handle out about 1/2" and then swinging it forward until it latches in the unlocked position. The red unlocked indicator will be visible from the cab.

**Note:** If the operating handle fails to latch in the unlock position while the kingpin is in the jaws, refer to steps 1 and 2 in the 'Preparation Troubleshooting' section on page 6. Never attempt to uncouple without the handle being in the unlocked position.

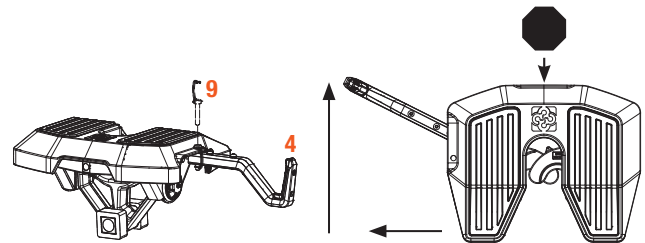

## Step 4

Remove the safety lynch pin (#9) from the handle (#4) of the 5th wheel. Remove the parking brake and slowly drive the tow vehicle out from under the trailer. If resistance is encountered, determine the corrective action and repeat uncoupling steps.

As the kingpin moves out of the 5th wheel jaws you will see the handle drop back slightly to the couple position. The indicator will also change from red to yellow.

Your 5th wheel hitch is now safely uncoupled and is ready to be recoupled the next time you tow.



# MAINTENANCE

## Maintenance

The CURT 5th wheel hitch has been designed to offer years of safe and reliable service. To achieve the best performance and the longest possible service life, please follow the maintenance schedule below.

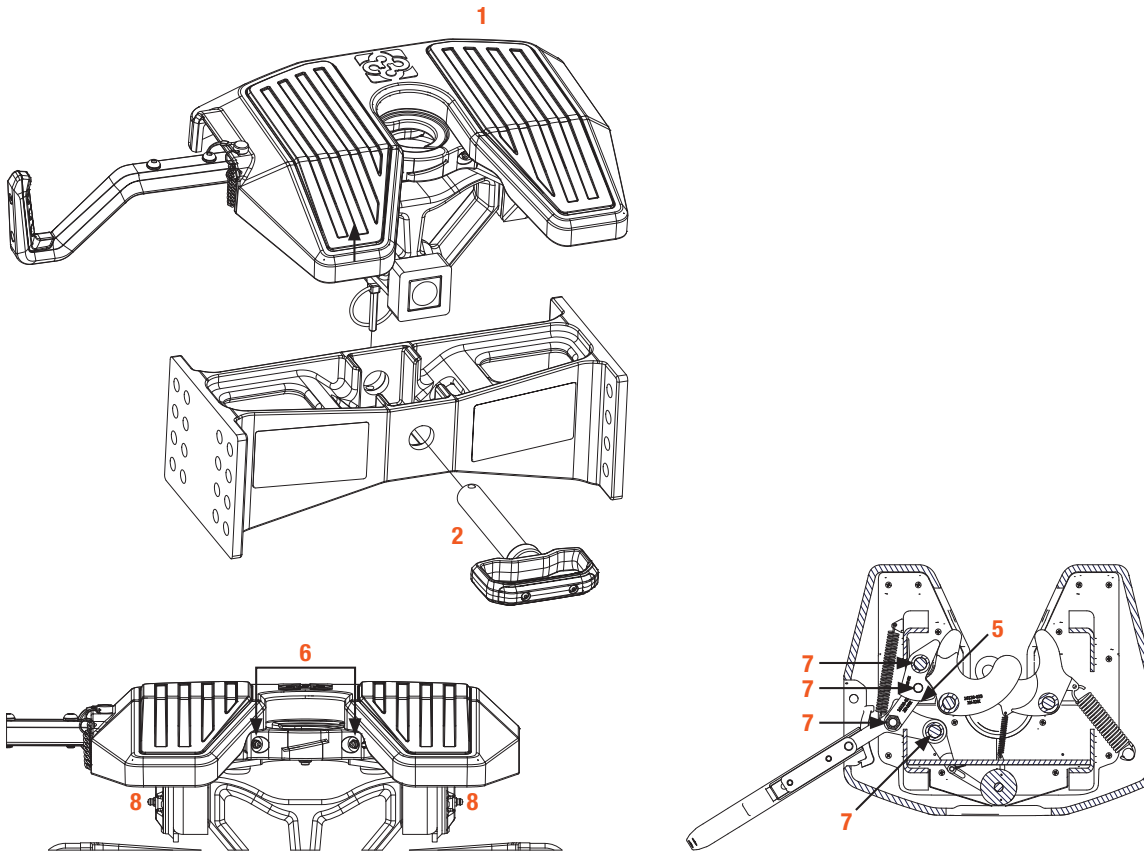

Component	Frequency	Instructions
<b>Inspect integrated wear plates</b>	Before each use and every 1,000 miles	Inspect the condition of the integrated wear plates on the skid plate's top surface (#1). When the grooves have worn flush they should be replaced. (CURT# 19269) If you prefer, you may use a lube plate installed on your trailer's kingpin (CURT# 16722) to further reduce wear.
<b>Lubricate the center pivot point</b>	Before each use	Remove the center pivot pin (#2) and apply a light coating of high-pressure wheel bearing grease. Replace the pin and ensure it is secured with the safety lynch pin.
<b>Torque the M14 hex bolts</b>	Before each use and every 1,000 miles	Torque the four M14 leg hex bolts to 100 ft-lbs. Re-torque after initial 500 miles and every 1,000 miles thereafter and prior to each individual use.
<b>Lubricate the locking pawl</b>	Before each use	Open jaws and apply a small amount of grease to the curved surface of locking pawl (#5). Pawl will be accessible through the operating handle opening in the head side plate.
<b>Lubricate the jaw pivot point</b>	Every 3,000 miles	Use a grease gun to apply grease to both zerks (#6) located on the front of each jaw. The jaws must be in the closed and locked position for the zerks to be accessible.
<b>Lubricate the linkage pivot points</b>	Before each use	Use an aerosol applicator to spray a small amount of rust inhibitor or lubricant on the lock handle (#7), linkage bar (#7) and pawl pivot points (#7).
<b>Lubricate the head pivot points</b>	Every 3,000 miles	Use a grease gun to apply grease to both zerks (#8) located on both sides of the head.
<b>Clean the 5th wheel hitch</b>	After each use and before long term storage	For optimal service life, clean your 5th wheel hitch after each use with warm soapy water and dry with towels or compressed air. It is also recommended that the 5th wheel is removed from the vehicle or covered when not in use for extended periods of time. Spray exposed surfaces with a light coat of rust inhibitor before long term storage.

Discover other trailer hitches and towing on our website.