



INSTALLATION MANUAL

16100 & 16200

Level of Difficulty

Moderate

⚠ WARNING

Never exceed the vehicle manufacturer's recommended towing capacity.

Parts List

#	Qty	Description
1	2	Base rail
2	1	Long mounting bracket, right
3	1	Short mounting bracket, right
4	1	Short mounting bracket, left
5	1	Long mounting bracket, left
6	10	U-shaped spacer, 5/16"
7	8	Ribbed neck bolt, 1/2" - 13 x 1-1/2"
8	10	Carriage bolt, 1/2" - 13 x 2"
9	18	Lock washer, 1/2"
10	18	Hex nut, 1/2" - 13
11	10	Flat washer, 1/2"
12	2	Round hole spacer, 1/2" x 1-1/4" x 2-1/2"
13	2	Carriage bolt, 1/2" - 13 x 4-1/2"
14	2	Round tube spacer, 1" OD x 14 GA, A-513
15	1	Fish wire

Tools Required

Torque wrench	Socket set
Drill	3/16" drill bit
Wrench, 3/4"	7/32" drill bit
Socket, 3/4"	C-clamps
1" drill bit (for some Dodge applications)	

Torque Specifications

1/4" bolt	122 in-lbs.
5/16" bolt	251 in-lbs.
3/8" bolt	37 ft-lbs.
7/16" bolt	59 ft-lbs.
1/2" bolt	106 ft-lbs.

Use above torque setting unless otherwise noted

Product Photo



Notes and Maintenance

Before you begin installation, read all instructions thoroughly.

Proper tools will improve the quality of installation and reduce the time required.

Custom mounting brackets required on some installations

Dealers: Provide this installation manual to the end user. Physically demonstrate all procedures in this manual to the end user. Have the end user demonstrate that they understand procedures.

End Users: Read and follow this installation manual every time you use a hitch. Save this manual for future reference. Pass on copies of this manual to any other user or owner of hitch.

Refer to the table to the left when securing hardware during the installation process to help prevent damage to the product or vehicle.

ASSEMBLY

Parts List

#	Qty	Description
1	2	Base rail
2	1	Long mounting bracket, right
3	1	Short mounting bracket, right
4	1	Short mounting bracket, left
5	1	Long mounting bracket, left
6	10	U-shaped spacer, 5/16"
7	8	Ribbed neck bolt, 1/2" - 13 x 1-1/2"
8	10	Carriage bolt, 1/2" - 13 x 2"
9	18	Lock washer, 1/2"
10	18	Hex nut, 1/2" - 13
11	10	Flat washer, 1/2"
12	2	Round hole spacer, 1/2" x 1-1/4" x 2-1/2"
13	2	Carriage bolt, 1/2" - 13 x 4-1/2"
14	2	Round tube spacer, 1" OD x 14 GA, A-513
15	1	Fish wire

⚠ READ THE FOLLOWING BEFORE BEGINNING THE INSTALLATION

Do not install the base rails over plastic bed liners. Plastic bed liners must be cut out of the way. Base rails may be installed on a spray liner. Consult an installer for curing times.

Only use the provided grade 8 bolts, nuts and washers for installation. All installation hardware is grade 8 unless otherwise specified.

Specific instructions for common vehicles are included. If these instructions do not apply to your vehicle, be sure that each end of each base rail is connected to the vehicle's frame. Each frame bracket must be secured with two bolts unless optional weld is used.

⚠ WARNING: This installation manual is only a guideline. The installation is the responsibility of the installer and the owner. Always measure the truck and trailer before installing the hitch to ensure there is clearance at the cab and bumper to allow for turns.

To prevent the trailer from hitting the cab when turned 90°, the center of the hitch should be at least 52" from the back of the cab when using a long bed truck. The actual distance will depend on the trailer width and king pin location. Short bed (38" minimum from the back cab to the axle center line) trucks require a minimum of a 13" extended pin box for regular maneuvers. 52" does not apply.

For most applications, measurements are given from the rear edge of the truck bed to the rear edge of the mounting rail that is closest to the rear edge of truck. See the illustration on page 3.

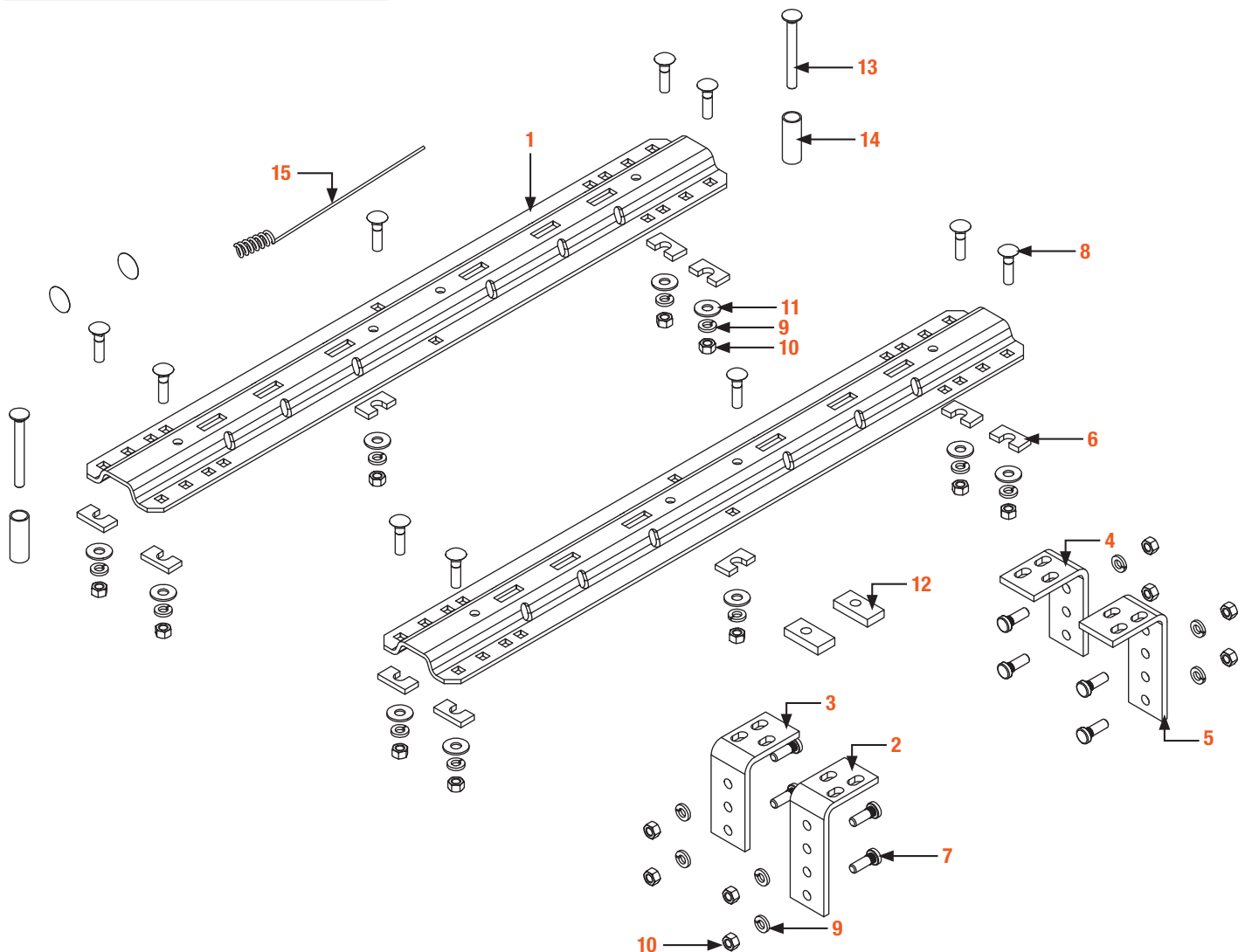

INSTALLATION

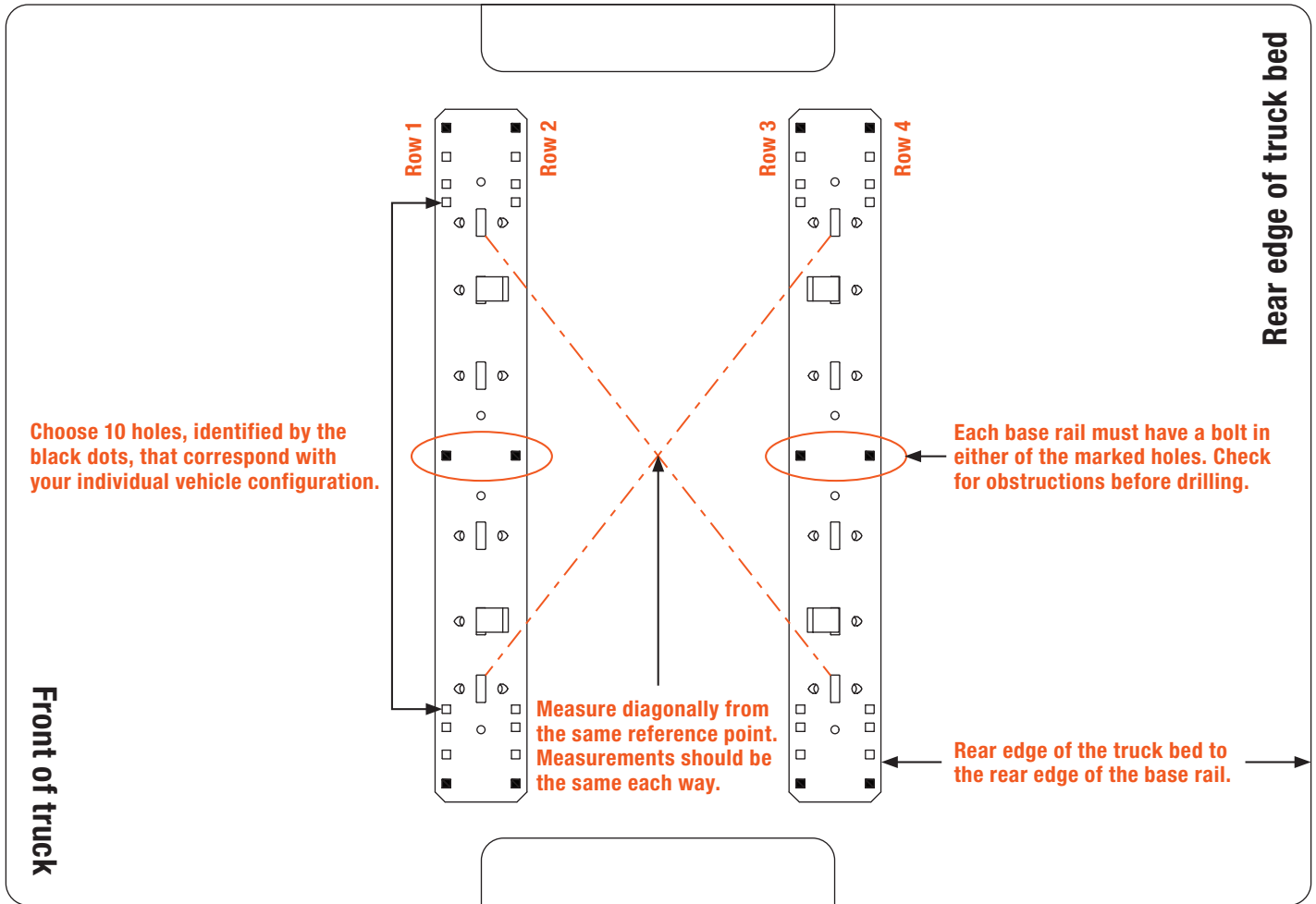

⚠ WARNING

Do not lubricate bolt threads. This may cause bolt failure.

Check for obstructions prior to drilling. Failure to do so could result in damaged fuel or brake lines, structural members, etc.

If the truck is raised, ensure it is properly blocked and restrained to prevent it from falling. Failure to do so may result in the truck falling suddenly, causing death or serious injury.

⚠ CAUTION

It is important to use a 17/32" drill bit for holes in the chassis frame. The rib neck bolts may break if too small of a hole is drilled. The rib neck bolts may not grip if too large of a hole is drilled.

Drill locations will vary per application.

See individual sheets for specific drill locations.

Diagonal measurements must be the same to ensure smooth operation of 5th wheel roller units.

Use the mounting channel / cross member assembly to position the base rails, sold separately.

Step 1

The following instructions should be used to mount the base rails.

Raise the rear of the truck high enough to allow jack stands to be placed under the rear spring hanger bracket. This will provide the maximum amount of space to install the 5th wheel brackets.

⚠ WARNING: If the truck is raised, ensure it is properly blocked and restrained to prevent it from falling. Failure to do so may result in the truck falling suddenly, causing death or serious injury.

Step 2

Center the 5th wheel hitch between the fender wells and make sure the base rails are square. Adjust the position of the rails until both diagonal measurements are the same. This should allow the installation of a gooseneck or 5th wheel hitch to these rails.

Installation continues on the following page

INSTALLATION (CONTINUED)

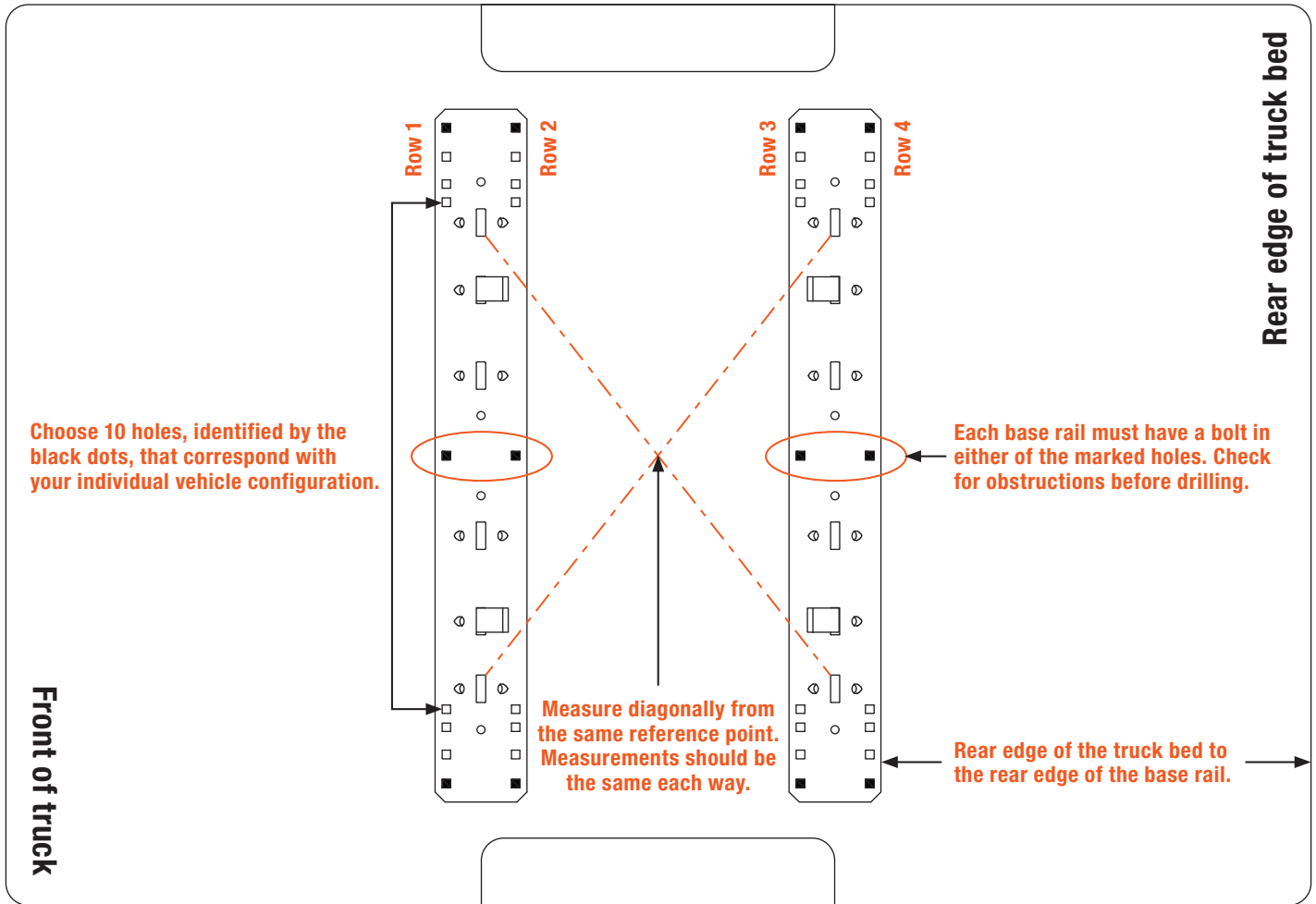

Step 3

▲ WARNING: Check for obstructions prior to drilling. Failure to do so could result in damaged fuel or brake lines, structural members, etc.

Drill the 10 holes identified in the figure above. **Note:** Hole location will vary for all applications. Drill all holes with a 3/16" drill bit first, and enlarge them with a 17/32" drill bit.

Insert 1/2" - 13 x 2" carriage bolts (#8) into each hole. Insert 5/16" U-shaped spacers (#6) above or below the truck bed to fill corrugations in the bed floor.

Note: The Toyota Tundra application requires CURT #16302 spacer kit. Stack one 3/16" and one 5/16" U-shaped spacer to avoid crushing the truck bed.

Step 4

Install the mounting brackets over the carriage bolts (#8) with the long mounting brackets (#2, #5) on the front bolts and short mounting brackets (#3, #4) on the rear bolts. **Note:** Long and short brackets can be interchanged as needed.

Secure the carriage bolts (#8) through the mounting brackets with flat washers (#11), lock washers (#9) and hex nuts (#10). Secure the last four carriage bolts (#8) through the truck bed with flat washers (#11), lock washers (#9) and hex nuts (#10). Torque all nuts to 110 lb-ft.

Step 5

Drill two holes in the frame for each bracket. Select the holes that will give the largest spread between bolts. Install eight 1/2" - 13 x 1-1/2" ribbed neck bolts (#7) with the threads pointing outward, lock washers (#9) and hex nuts (#10). Use the provided fish wire (#15) to pull the rib neck bolts through the frame as needed.

Tighten the nuts until the bolt heads seat. Lubrication of knurls of all rib neck bolts is recommended. Torque all nuts to 110 lb-ft.

Note: On vehicles with heavy-duty suspensions, check for interference with the bolts where the brackets are mounted to the frame. If there is interference with the suspension springs, cut the bolts flush to the nut outboard of the frame or use the weld option.

VEHICLE-SPECIFIC INSTALLATION

Chevrolet Silverado Classic / GMC Sierra Classic

88 - 98 / 92 - 98 4-door / 1999 with tapered frame and red turn signals

⚠ WARNING

Read pages 2 - 4 of this installation manual before beginning the installation. Failure to do so could result in significant vehicle damage.

Check for obstructions prior to drilling. Failure to do so could result in damaged fuel or brake lines, structural members, etc.

CURT does its best to communicate tow vehicle manufacturer changes. However, it is ultimately the responsibility of the installer to prevent damage due to installation.

IMPORTANT NOTE

Find parallel rows of bed sill spot welds in the bed of the truck. No drilling should be done in the ~4" between parallel rows of spot welds where the bed sill sits.

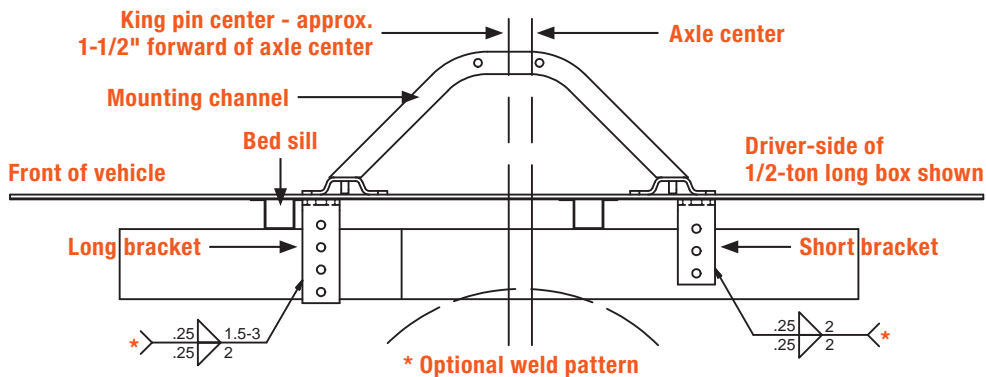
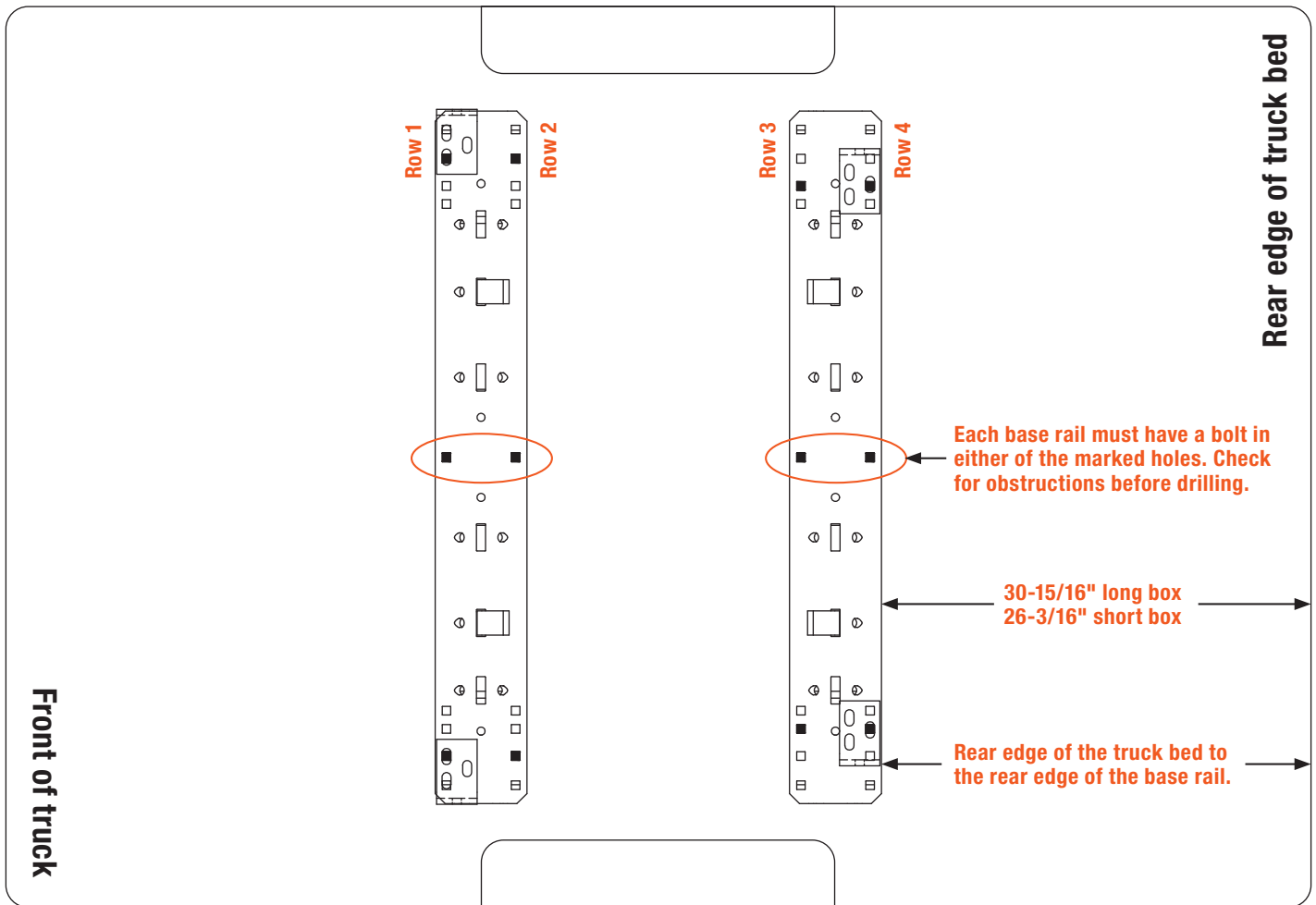

VEHICLE-SPECIFIC INSTALLATION

**Chevrolet Silverado / GMC Sierra 1999 (excluding Sierra Classic)
Chevrolet Silverado / GMC Sierra 00 - 10 (including HD models)**

⚠ WARNING

Read pages 2 - 4 of this installation manual before beginning the installation. Failure to do so could result in significant vehicle damage.

Check for obstructions prior to drilling. Failure to do so could result in damaged fuel or brake lines, structural members, etc.

CURT does its best to communicate tow vehicle manufacturer changes. However, it is ultimately the responsibility of the installer to prevent damage due to installation.

IMPORTANT NOTE

Find parallel rows of bed sill spot welds in the bed of the truck. No drilling should be done in the ~4" between parallel rows of spot welds where the bed sill sits.

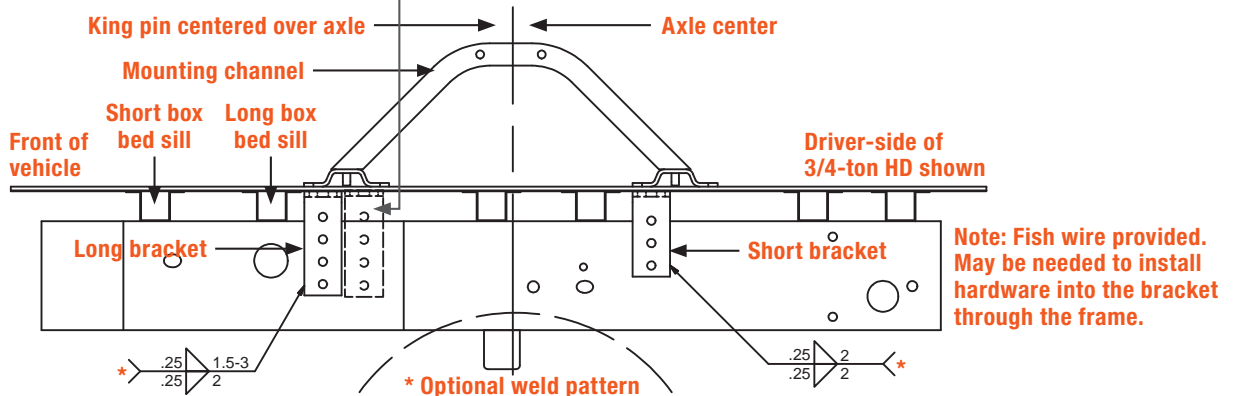
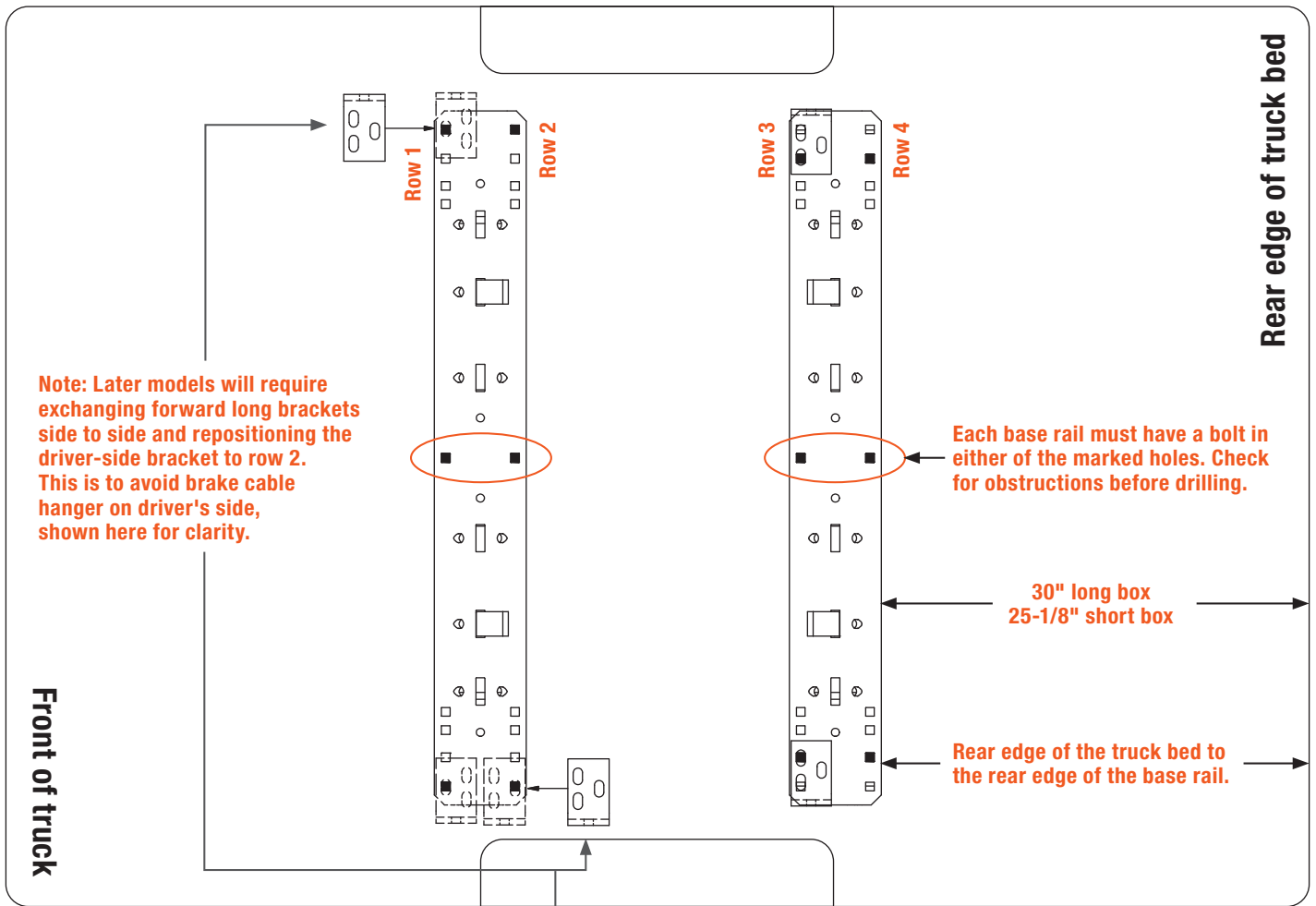

VEHICLE-SPECIFIC INSTALLATION

Chevrolet Silverado / GMC Sierra 1500, 2500, 3500
2011 and newer

⚠ WARNING

Read pages 2 - 4 of this installation manual before beginning the installation. Failure to do so could result in significant vehicle damage.

Check for obstructions prior to drilling. Failure to do so could result in damaged fuel or brake lines, structural members, etc.

CURT does its best to communicate tow vehicle manufacturer changes. However, it is ultimately the responsibility of the installer to prevent damage due to installation.

IMPORTANT NOTE

Find parallel rows of bed sill spot welds in the bed of the truck. No drilling should be done in the ~4" between parallel rows of spot welds where the bed sill sits.

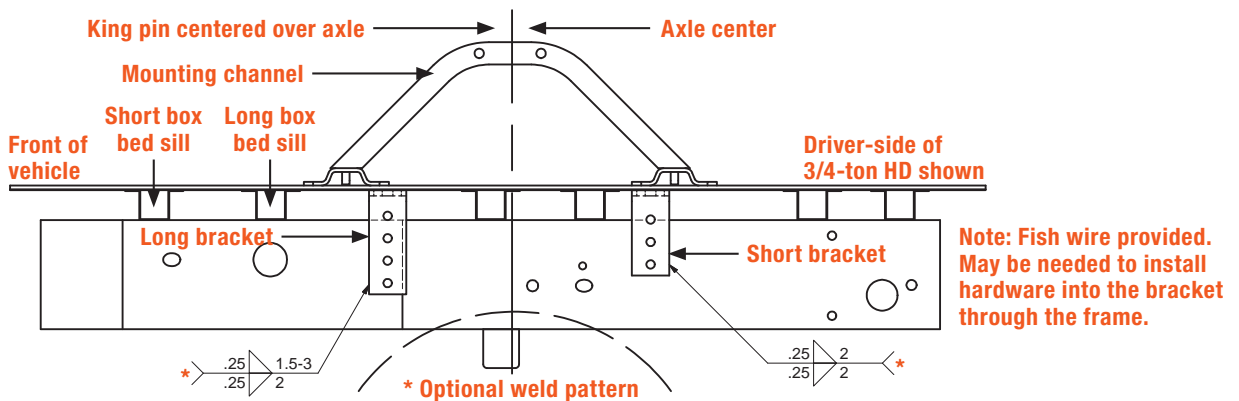
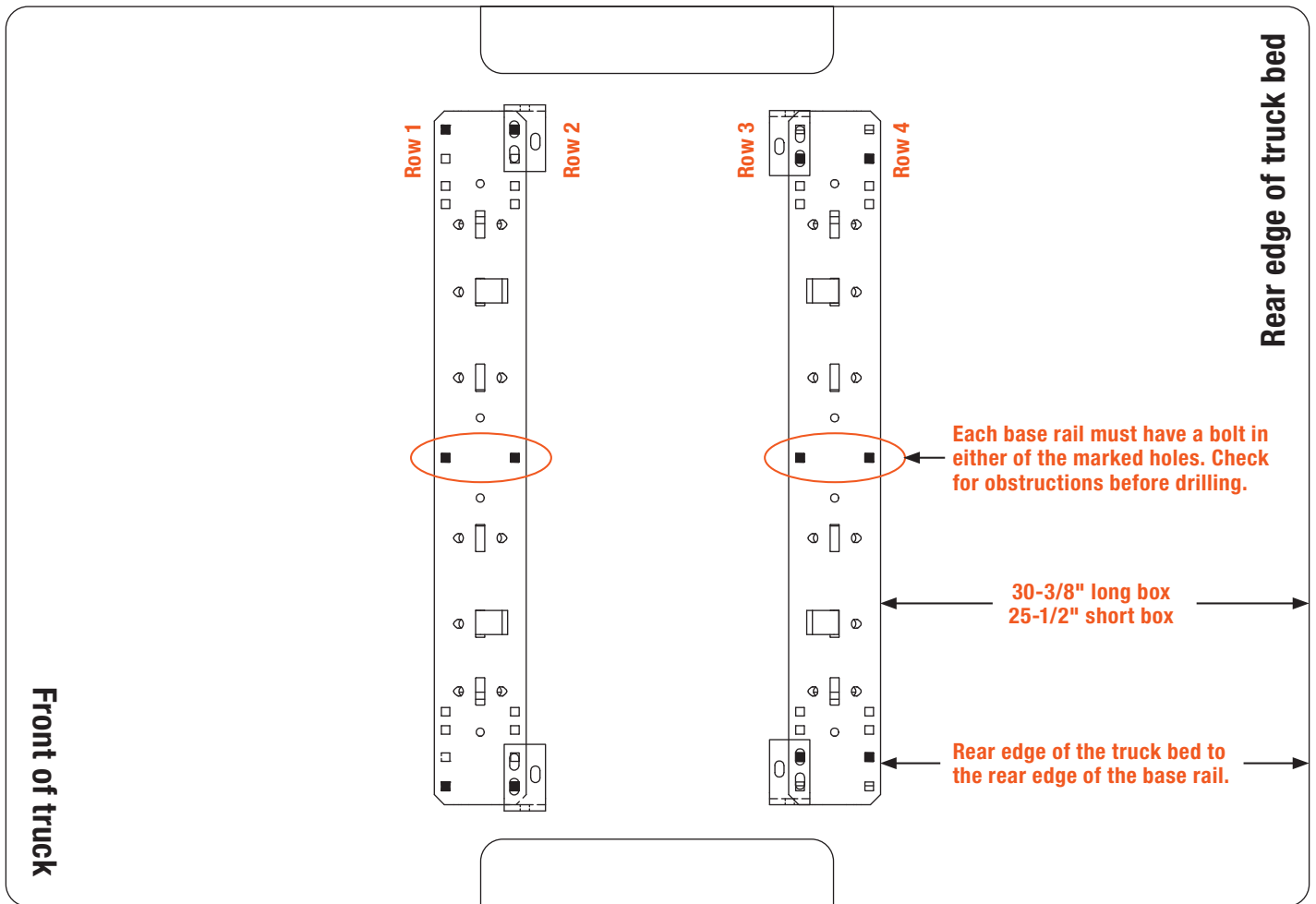

VEHICLE-SPECIFIC INSTALLATION

Chevrolet / GMC 4-door

73 - 87 / 73 - 92 (34" straight with outside shock absorbers)

⚠ WARNING

Read pages 2 - 4 of this installation manual before beginning the installation. Failure to do so could result in significant vehicle damage.

Check for obstructions prior to drilling. Failure to do so could result in damaged fuel or brake lines, structural members, etc.

CURT does its best to communicate tow vehicle manufacturer changes. However, it is ultimately the responsibility of the installer to prevent damage due to installation.

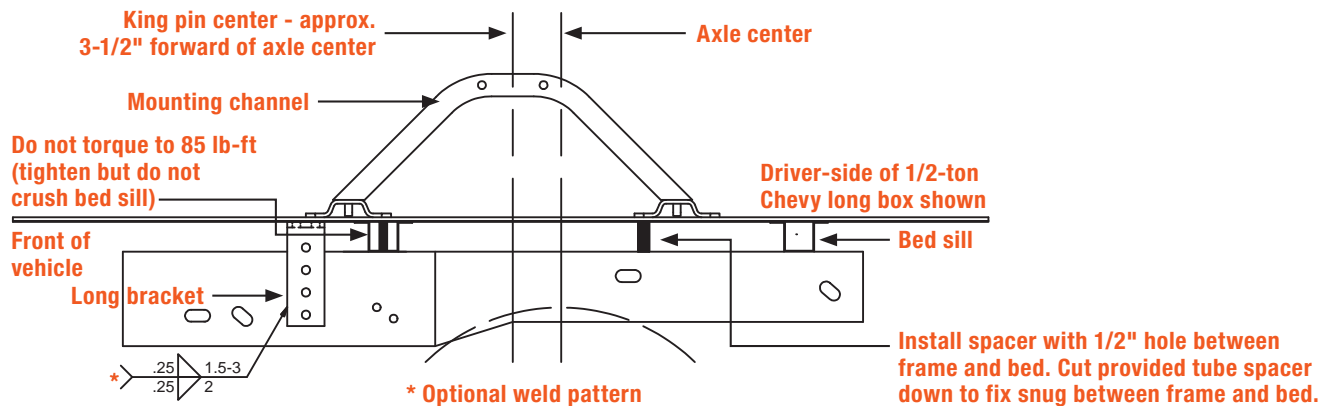
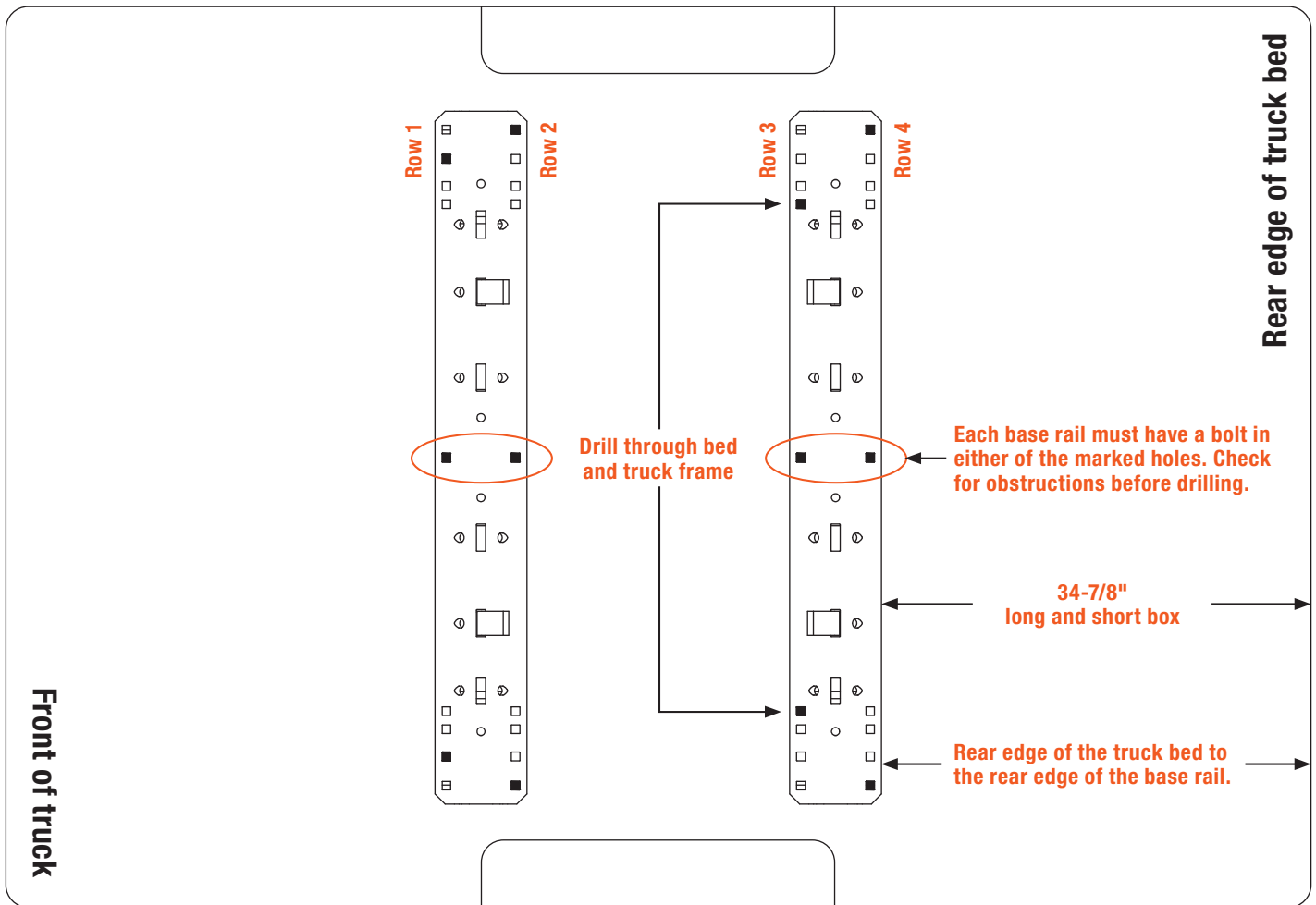

VEHICLE-SPECIFIC INSTALLATION

Chevrolet / GMC 4-door

73 - 87 / 73 - 92 (34" straight with inside shock absorbers)

⚠ WARNING

Read pages 2 - 4 of this installation manual before beginning the installation. Failure to do so could result in significant vehicle damage.

Check for obstructions prior to drilling. Failure to do so could result in damaged fuel or brake lines, structural members, etc.

CURT does its best to communicate tow vehicle manufacturer changes. However, it is ultimately the responsibility of the installer to prevent damage due to installation.

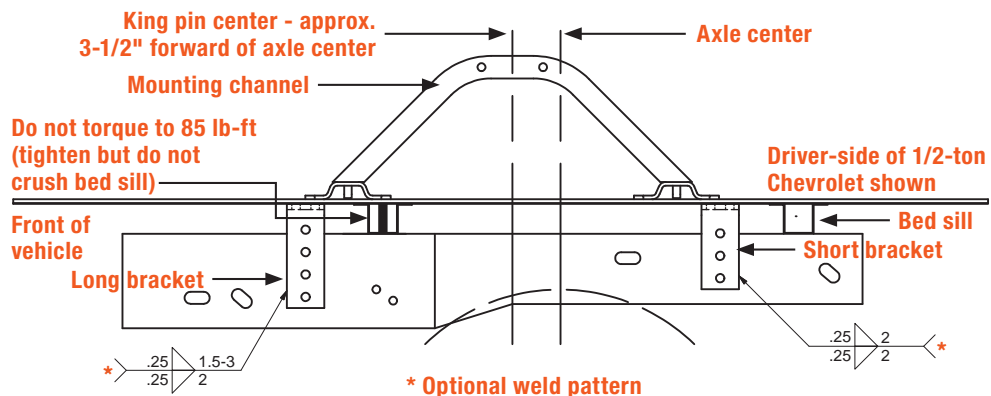
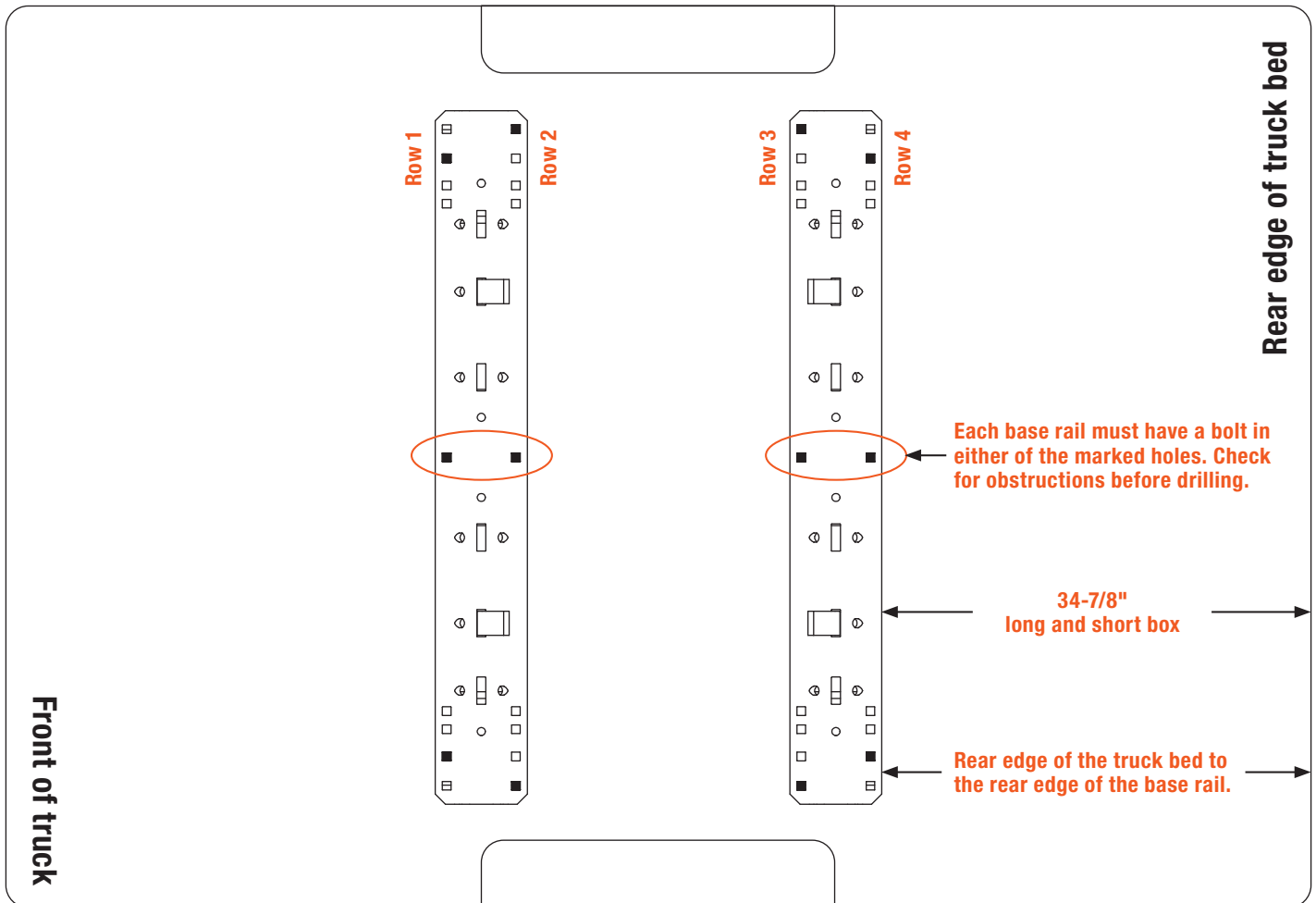

VEHICLE-SPECIFIC INSTALLATION

Ford F-150 / F-250 97 - 03 (8,500 max GVW)
Ford Heritage Edition 2004

⚠ WARNING

Read pages 2 - 4 of this installation manual before beginning the installation. Failure to do so could result in significant vehicle damage.

Check for obstructions prior to drilling. Failure to do so could result in damaged fuel or brake lines, structural members, etc.

CURT does its best to communicate tow vehicle manufacturer changes. However, it is ultimately the responsibility of the installer to prevent damage due to installation.

IMPORTANT NOTES

Long and short brackets on the driver-side may need to be switched to avoid interference with the exhaust hanger.

You may need to move mounting rail location +/- 1/2" to ensure frame brackets do not interfere with bed sills.

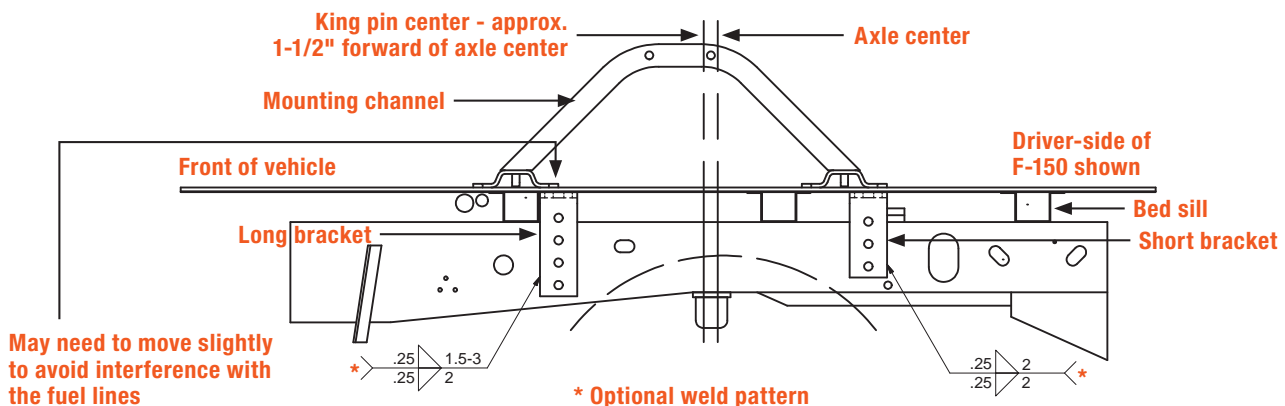
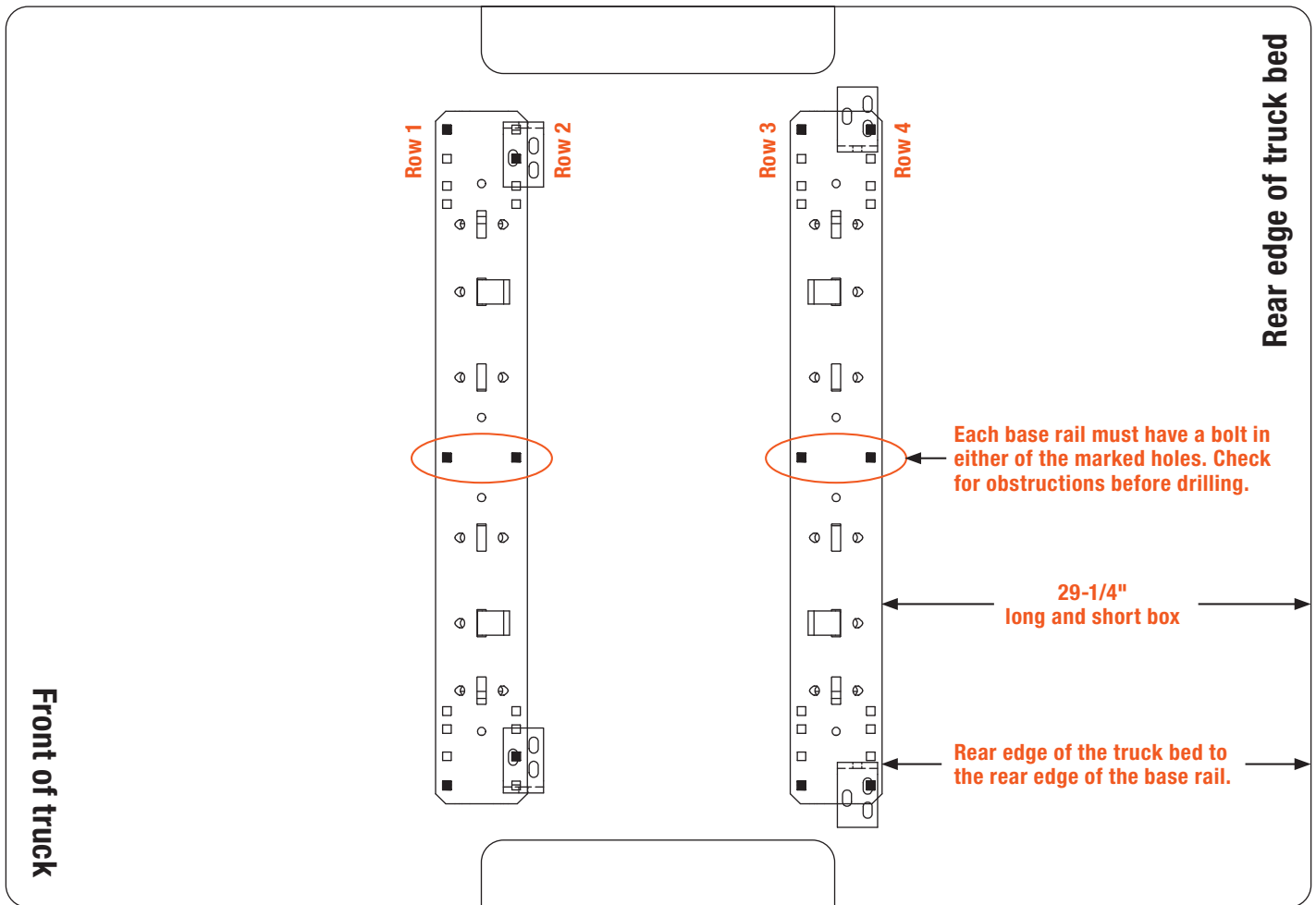

May need to move slightly to avoid interference with the fuel lines

* Optional weld pattern

VEHICLE-SPECIFIC INSTALLATION

Ford F-150 04 - 14 (excluding Heritage Edition)
Requires #16300 bracket kit

⚠ WARNING

Read pages 2 - 4 of this installation manual before beginning the installation. Failure to do so could result in significant vehicle damage.

Check for obstructions prior to drilling. Failure to do so could result in damaged fuel or brake lines, structural members, etc.

CURT does its best to communicate tow vehicle manufacturer changes. However, it is ultimately the responsibility of the installer to prevent damage due to installation.

IMPORTANT NOTES

Do not drill through both walls of the frame. Drill only through the wall to which the bracket is mounted.

Find parallel rows of bed sill spot welds in the bed of the truck. No drilling should be done in the ~4" between parallel rows of spot welds where the bed sill sits.

Step 1

Remove the jounce block from the bottom of the frame on both sides.

Step 2

When the brackets are in place, one of the front two holes should line up with a hole in the frame. A hole will need to be drilled in the frame at the rearward bracket hole.

Step 3

Using the provided fish wire, pull the carriage bolts with bolt plates through the hole in the bottom of the frame where the jounce block was removed and through the rear hole in each bracket.

On the forward brackets, a carriage bolt, spacer and a 1" washer should be pulled through the forward hole. On the rearward brackets a carriage bolt, spacer and 13/16" washer should be pulled through.

Replace the jounce block.

Front of truck

Row 1

Row 2

Row 3

Row 4

Rear edge of truck bed

Drill the two center holes shown in addition to eight holes for the round tube spacer. Install 1/2" carriage bolts, U-shaped spacers above or below the bed to fill the bed corrugation, and bolt plate below the bed with washer and nut.

29-5/16" long and short box

Rear edge of the truck bed to the rear edge of the base rail.

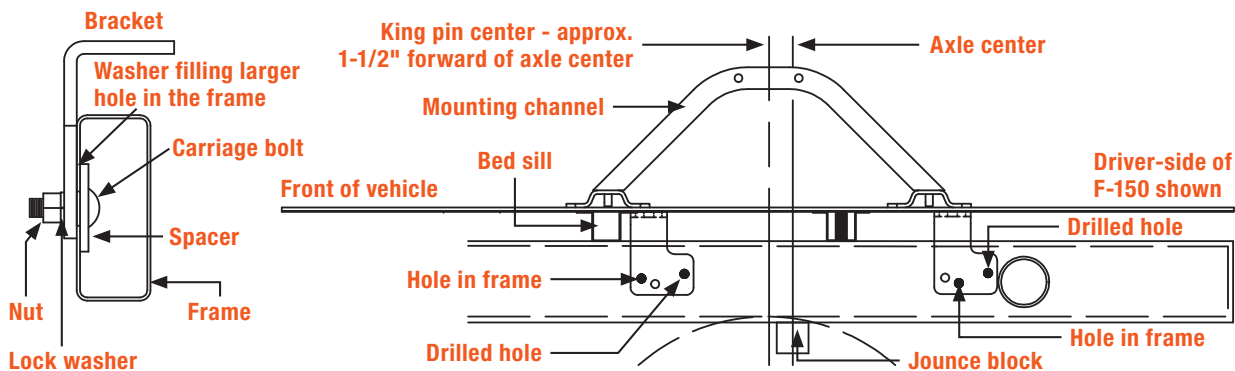

VEHICLE-SPECIFIC INSTALLATION

Ford F-150 and F-250 through 1996 / Ford F-250 1997 (over 8,500 GVW) /
 Ford F-350 through 1997 / Ford F-250, F-350, F-450 Super Duty (excl cab and chassis) 99 - 04

⚠ WARNING

Read pages 2 - 4 of this installation manual before beginning the installation. Failure to do so could result in significant vehicle damage.

Check for obstructions prior to drilling. Failure to do so could result in damaged fuel or brake lines, structural members, etc.

CURT does its best to communicate tow vehicle manufacturer changes. However, it is ultimately the responsibility of the installer to prevent damage due to installation.

IMPORTANT NOTES

On short bed vehicles, attach the driver-side forward bracket on row two to avoid interference with the fuel lines.

On vehicles with overload springs, switch the position of the long and short brackets.

You may need to move the base rail location +/- 1/2" to ensure the frame brackets do not interfere with the bed sills.

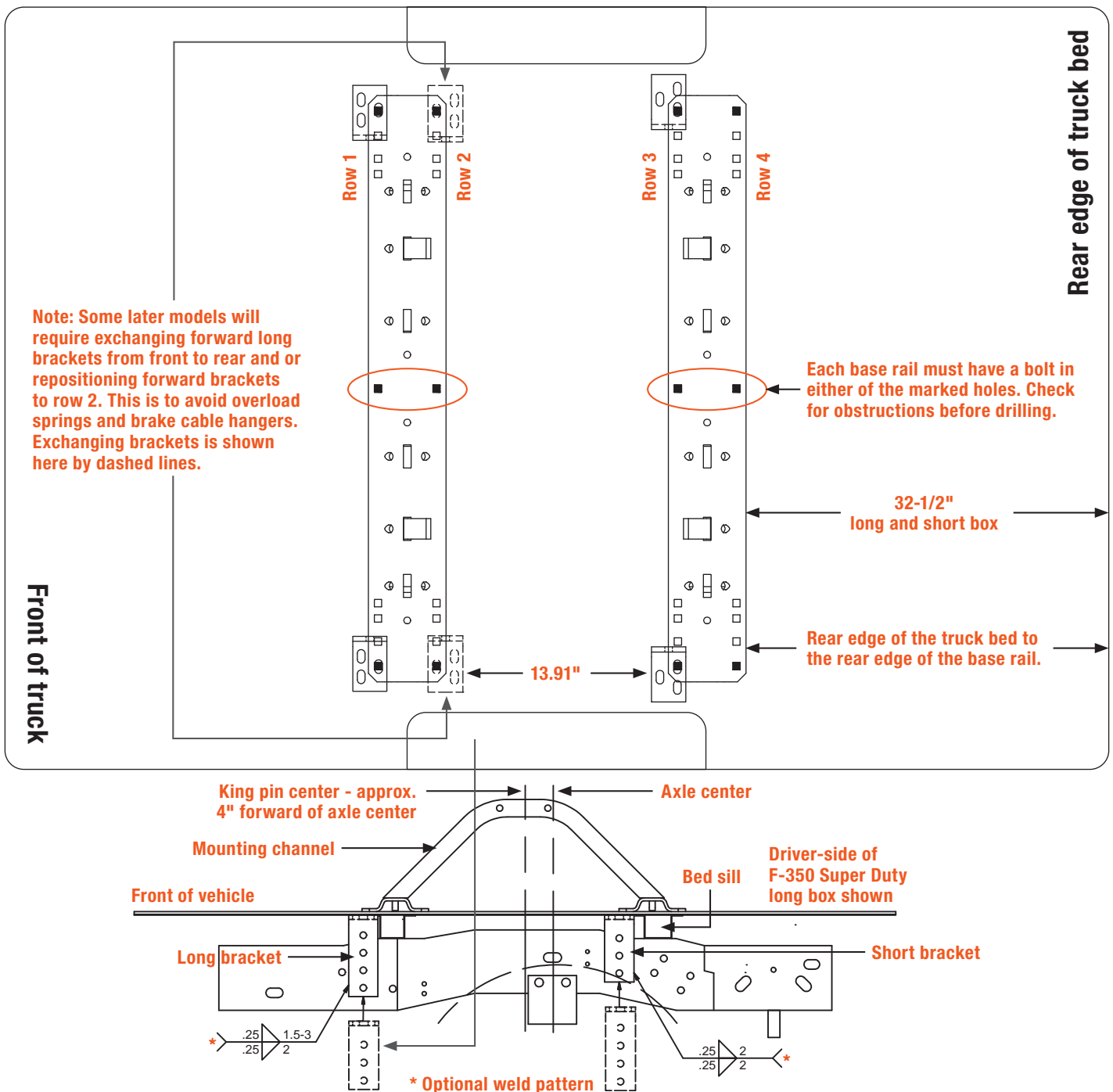

VEHICLE-SPECIFIC INSTALLATION

Dodge Ram 1500 02 - 08

Dodge Ram 2500 03 - 12 (without overload brackets)

⚠ WARNING

Read pages 2 - 4 of this installation manual before beginning the installation. Failure to do so could result in significant vehicle damage.

Check for obstructions prior to drilling. Failure to do so could result in damaged fuel or brake lines, structural members, etc.

CURT does its best to communicate tow vehicle manufacturer changes. However, it is ultimately the responsibility of the installer to prevent damage due to installation.

IMPORTANT NOTES

Do not drill through both walls of the frame. Drill only through the wall to which the bracket is mounted.

Tube spacer and 4-1/2" carriage bolt are used to attach through the rearward bed sill, row 3.

Notes continued in the illustration below

Additional Notes

** The rib neck bolts will need to be pulled through the access holes in the frame with the provided fish wire.

It is very important that the brackets in row 2 are against the rear side of the bed sill, as shown. Due to the dimensional instability in the bed sill placement with the Dodge truck, interference could result when drilling in row 3. Observe the warning note above and double check all areas prior to drilling.

To avoid drilling inside the frame (passenger-side row 3) optional custom bracket #16303 can be purchased. The use of this bracket allows for drilling outside the frame and avoids the exhaust hanger.

* Due to the tubular frames having thinner walls than the previous C-channel frames, extra caution needs to be used when mounting with the optional welding.

Front of truck

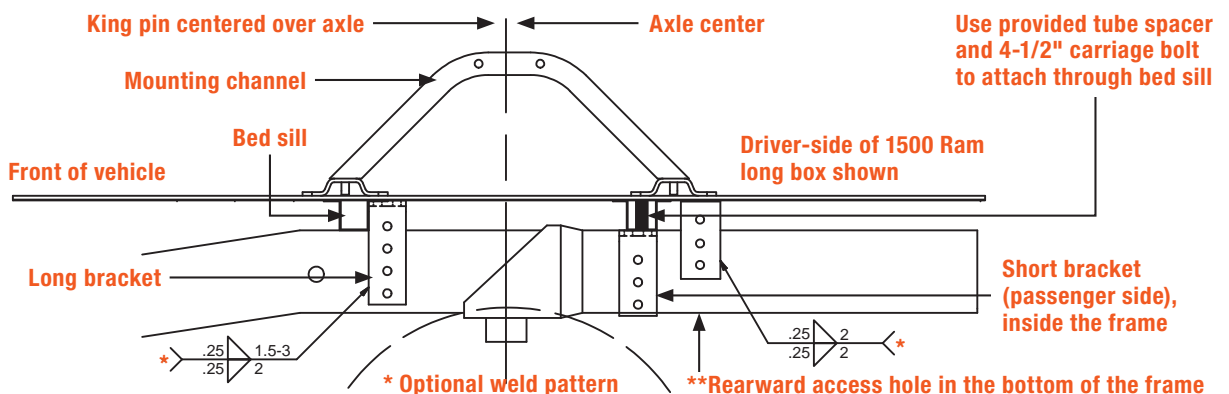
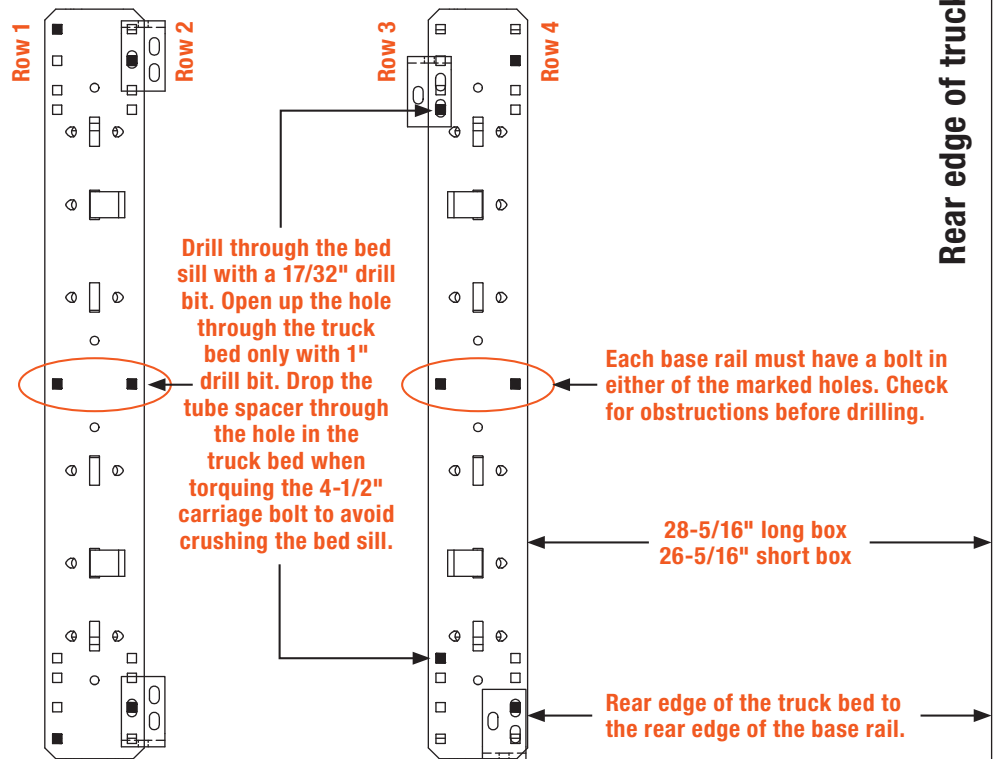

VEHICLE-SPECIFIC INSTALLATION

Dodge 2500 / 3500 (with overload springs) 03 - 12
Requires #16301 bracket kit

⚠ WARNING

Read pages 2 - 4 of this installation manual before beginning the installation. Failure to do so could result in significant vehicle damage.

Check for obstructions prior to drilling. Failure to do so could result in damaged fuel or brake lines, structural members, etc.

CURT does its best to communicate tow vehicle manufacturer changes. However, it is ultimately the responsibility of the installer to prevent damage due to installation.

IMPORTANT NOTES

Do not drill through both walls of the frame. Drill only through the wall to which the bracket is mounted.

Tube spacer and 4-1/2" carriage bolt are used to attach through the rearward bed sill, row 3.

Notes continued in the illustration below

Additional Notes

** The rib neck bolts will need to be pulled through the access holes in the frame with the provided fish wire.

It is very important that the brackets in row 2 are against the rear side of the bed sill, as shown. Due to the dimensional instability in the bed sill placement with the Dodge truck, interference could result when drilling in row 3. Observe the warning note above and double check all areas prior to drilling.

The rear brackets can be mounted to the frame with two bolts in any combination of the three bracket holes.

* Due to the tubular frames having thinner walls than the previous C-channel frames, extra caution needs to be used when mounting with the optional welding.

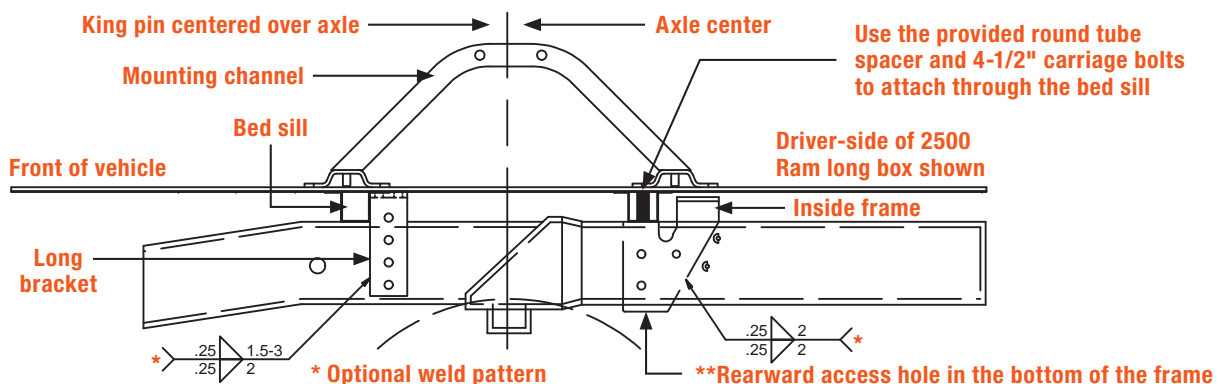
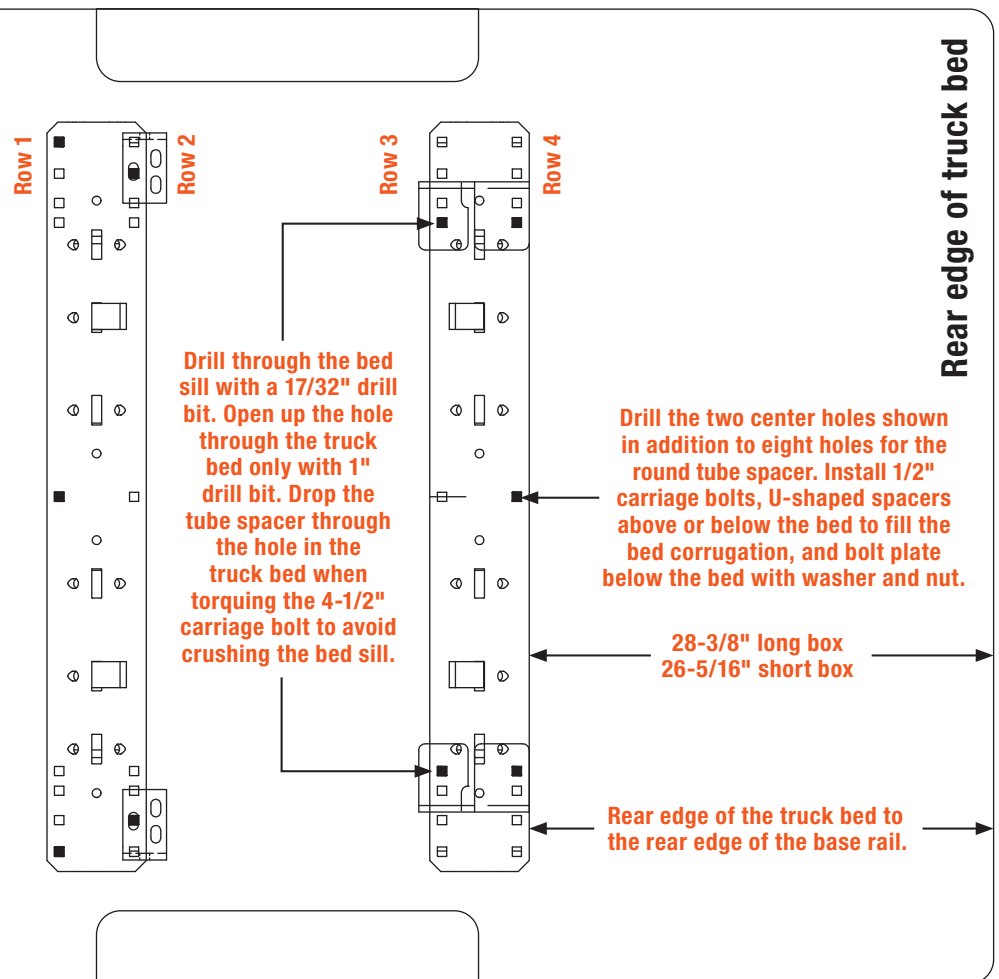

VEHICLE-SPECIFIC INSTALLATION

Dodge 1500 / 2500 (without overload springs) 02 - 08
Requires #16303 custom bracket kit

⚠ WARNING

Read pages 2 - 4 of this installation manual before beginning the installation. Failure to do so could result in significant vehicle damage.

Check for obstructions prior to drilling. Failure to do so could result in damaged fuel or brake lines, structural members, etc.

CURT does its best to communicate tow vehicle manufacturer changes. However, it is ultimately the responsibility of the installer to prevent damage due to installation.

IMPORTANT NOTES

Do not drill through both walls of the frame. Drill only through the wall to which the bracket is mounted.

Tube spacer and 4-1/2" carriage bolt are used to attach through the rearward bed sill, row 3.

Notes continued in the illustration below

Additional Notes

** The rib neck bolts will need to be pulled through the access holes in the frame with the provided fish wire.

It is very important that the brackets in row 2 are against the rear side of the bed sill, as shown. Due to the dimensional instability in the bed sill placement with the Dodge truck, interference could result when drilling in row 3. Observe the warning note above and double check all areas prior to drilling.

* Due to the tubular frames having thinner walls than the previous C-channel frames, extra caution needs to be used when mounting with the optional welding.

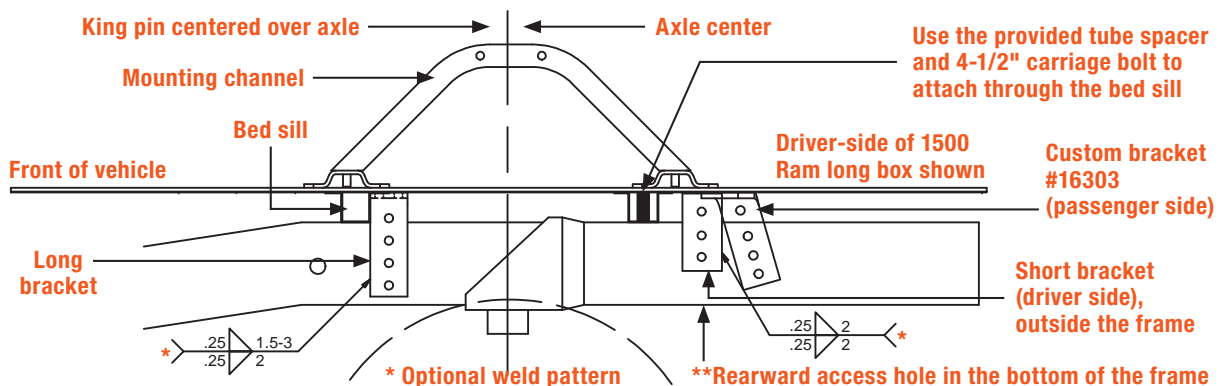
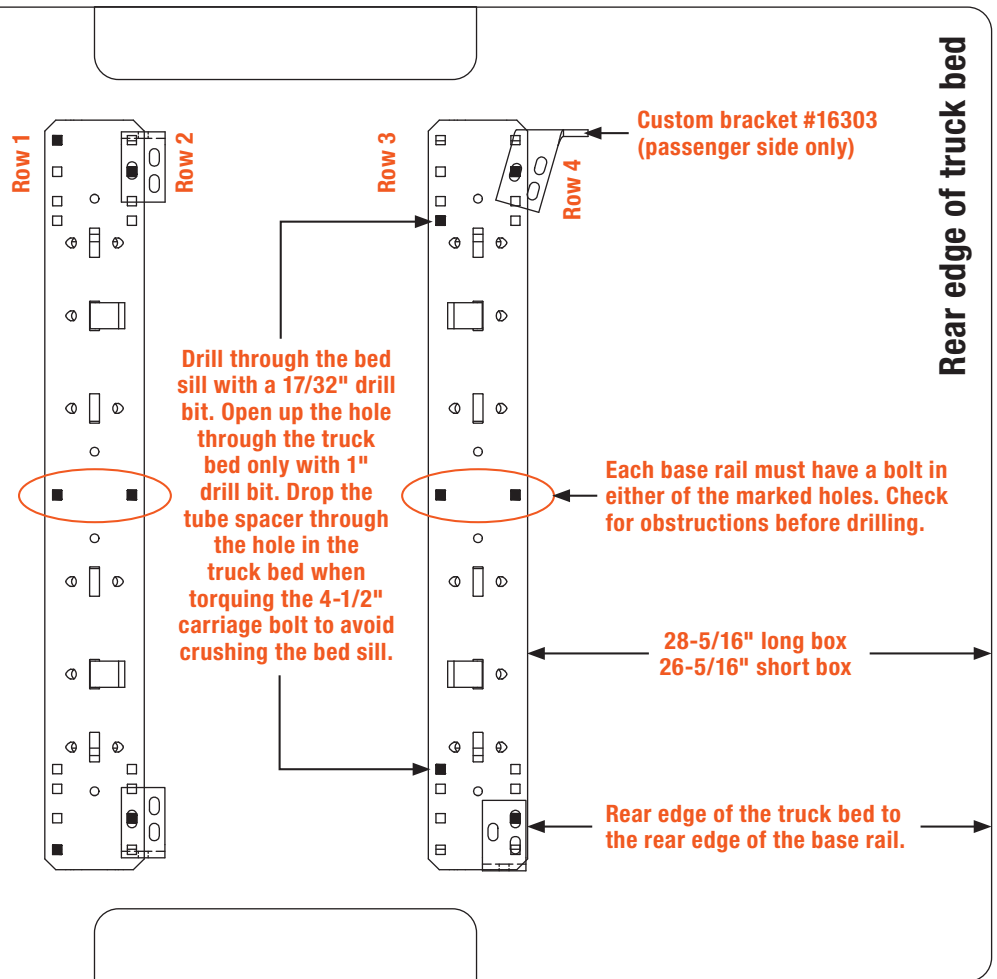

VEHICLE-SPECIFIC INSTALLATION

Dodge Ram 1500 09 - 10 and Ram 1500 11 - 18 (without factory air suspension)
Requires #16305 custom bracket kit

⚠ WARNING

Read pages 2 - 4 of this installation manual before beginning the installation. Failure to do so could result in significant vehicle damage.

Check for obstructions prior to drilling. Failure to do so could result in damaged fuel or brake lines, structural members, etc.

CURT does its best to communicate tow vehicle manufacturer changes. However, it is ultimately the responsibility of the installer to prevent damage due to installation.

IMPORTANT NOTES

Observe warning and double check all areas prior to drilling.

Notes continued in the illustration below

Additional Notes

* The rib neck bolts will need to be pulled through the access holes in the frame with the provided fish wire.

** Do not drill through both walls of the frame. Drill only through the wall to which the bracket is mounted.

*** It may be necessary to notch the ends of bed sill in row 3 to allow access to and the bolting down of base rail hardware.

**** Due to the tubular frames having thinner walls than the previous C-channel frames, extra caution needs to be used when mounting with the optional welding.

Front of truck

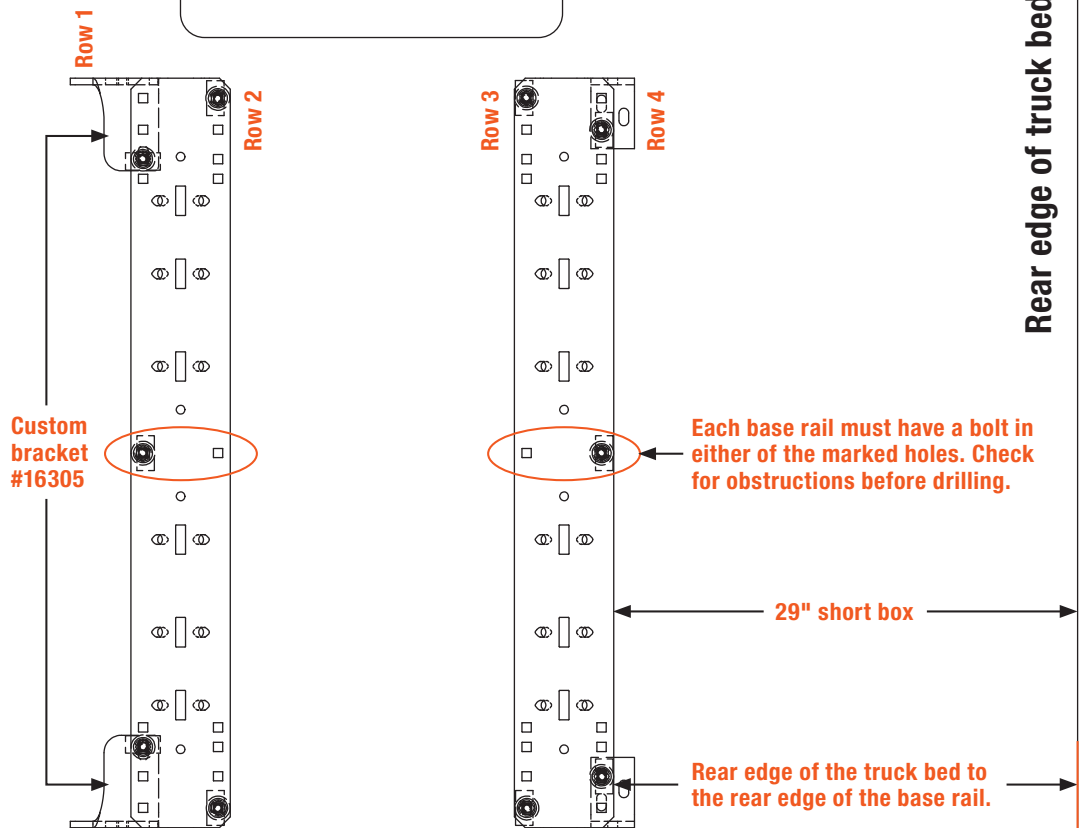

Rear edge of truck bed

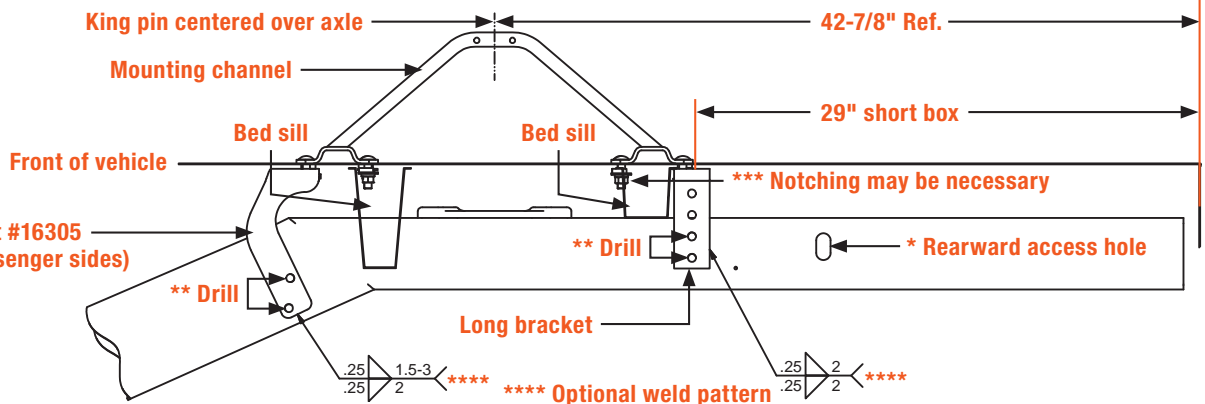

VEHICLE-SPECIFIC INSTALLATION

Dodge 1500 94 - 01

Dodge 2500 / 3500 94 - 02

⚠ WARNING

Read pages 2 - 4 of this installation manual before beginning the installation. Failure to do so could result in significant vehicle damage.

Check for obstructions prior to drilling. Failure to do so could result in damaged fuel or brake lines, structural members, etc.

CURT does its best to communicate tow vehicle manufacturer changes. However, it is ultimately the responsibility of the installer to prevent damage due to installation.

IMPORTANT NOTES

It is very important that the brackets in row 2 are against the forward side of the bed sill, as shown. Due to the dimensional instability in the bed sill placement with the Dodge truck, interference could result when drilling in rows 3 and 4. Observe the warning note above and double check all areas prior to drilling.

You may need to move the base rail location +/- 1/2" to ensure the frame brackets do not interfere with the bed sills.

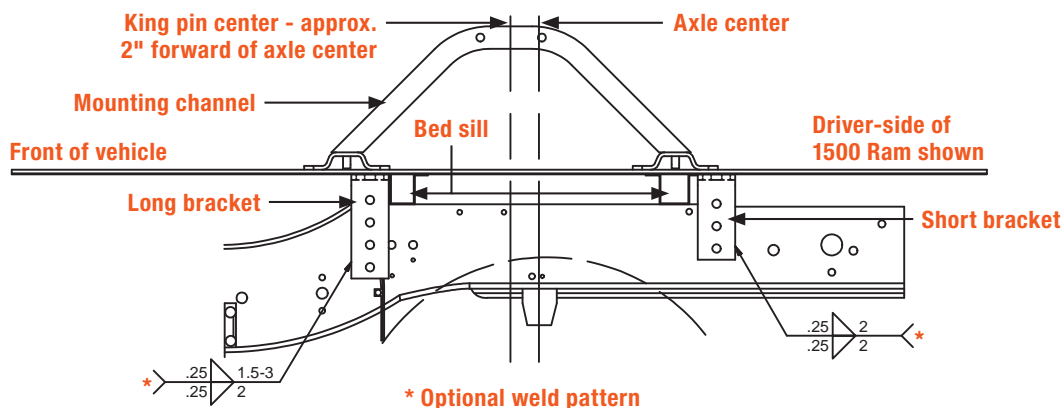
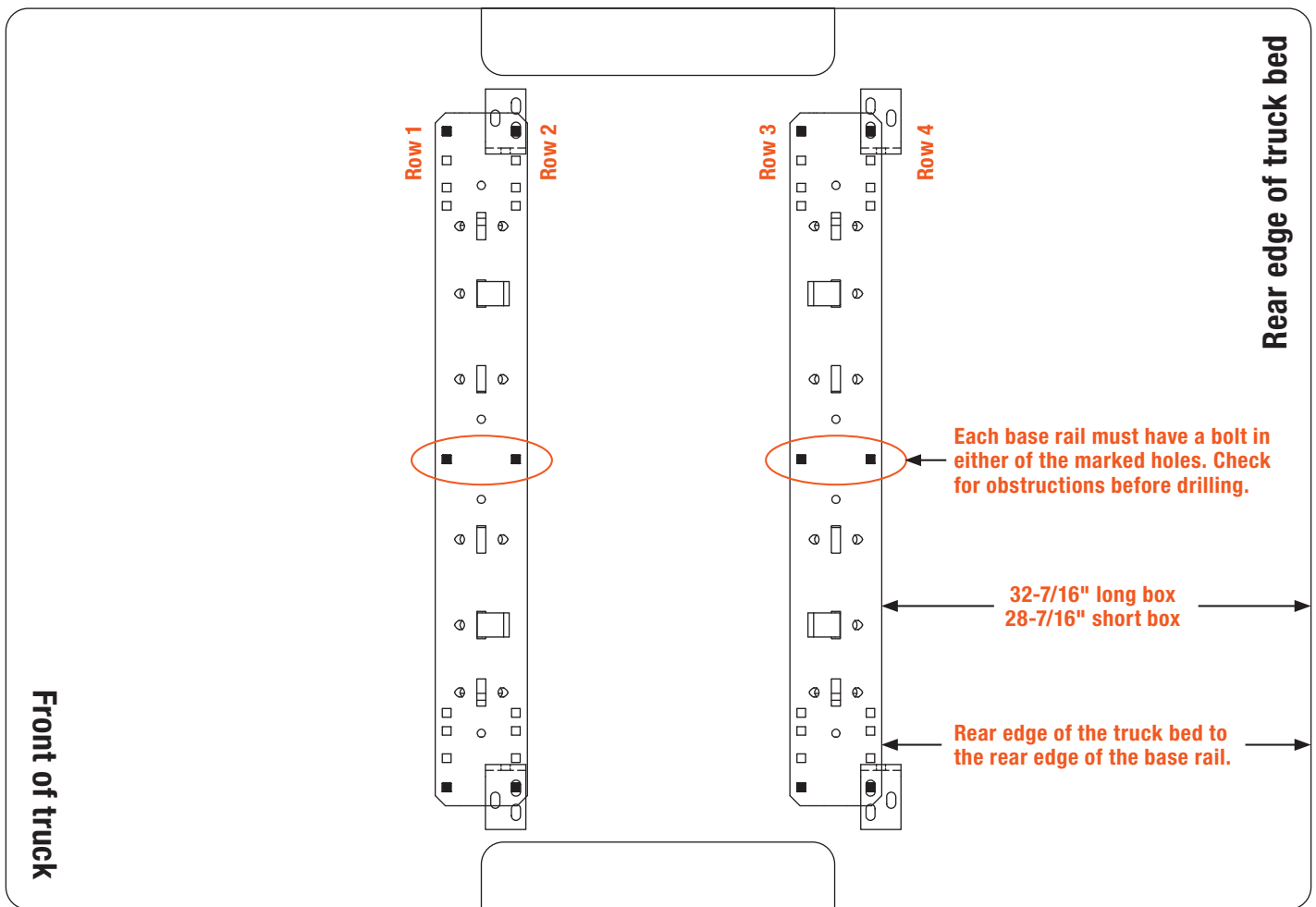

VEHICLE-SPECIFIC INSTALLATION

Dodge full size through 1993

⚠ WARNING

Read pages 2 - 4 of this installation manual before beginning the installation. Failure to do so could result in significant vehicle damage.

Check for obstructions prior to drilling. Failure to do so could result in damaged fuel or brake lines, structural members, etc.

CURT does its best to communicate tow vehicle manufacturer changes. However, it is ultimately the responsibility of the installer to prevent damage due to installation.

IMPORTANT NOTES

You may need to move the base rail location +/- 1/2" to ensure the frame brackets do not interfere with the bed sills.

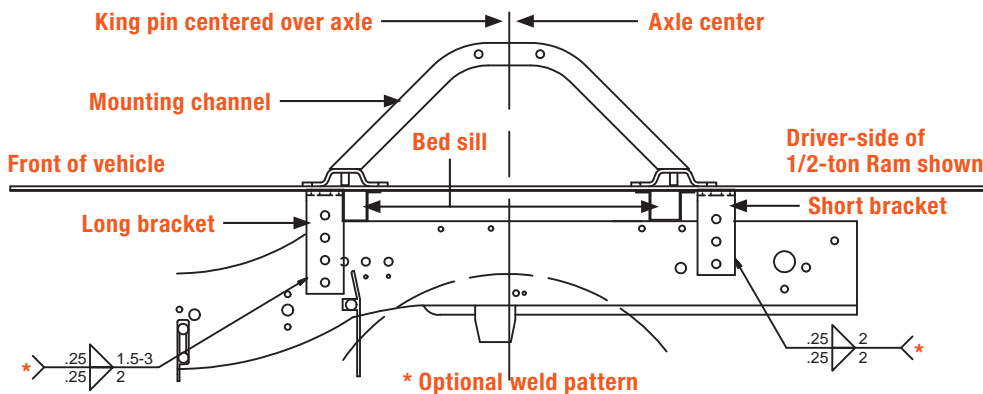
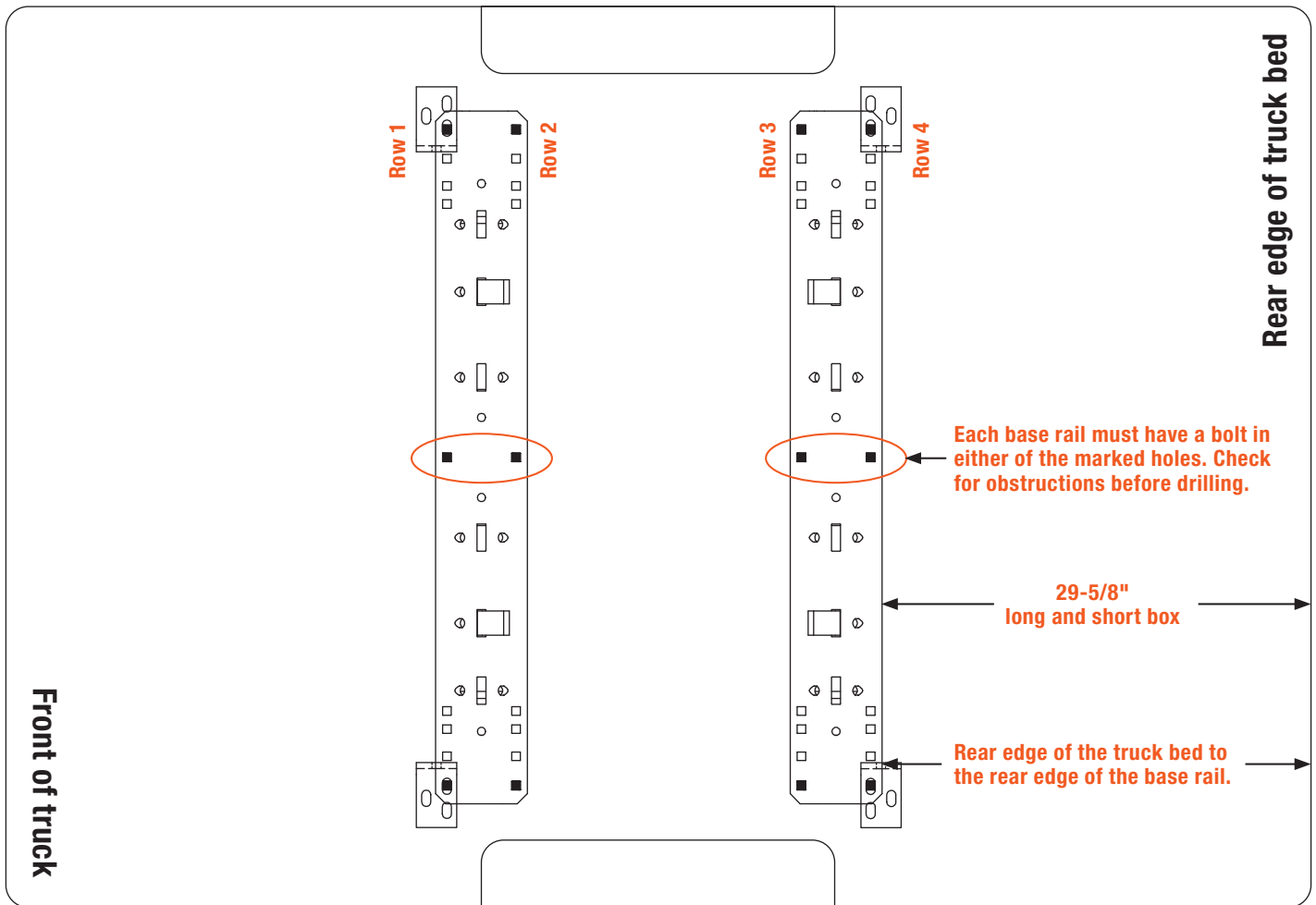

VEHICLE-SPECIFIC INSTALLATION

Dodge Dakota 94 - 04

⚠ WARNING

Read pages 2 - 4 of this installation manual before beginning the installation. Failure to do so could result in significant vehicle damage.

Check for obstructions prior to drilling. Failure to do so could result in damaged fuel or brake lines, structural members, etc.

CURT does its best to communicate tow vehicle manufacturer changes. However, it is ultimately the responsibility of the installer to prevent damage due to installation.

IMPORTANT NOTES

Find parallel rows of bed sill spot welds in the bed of the truck. No drilling should be done in the ~4" between parallel rows of spot welds where the bed sill sits.

Cut 1" from the top flange of the brackets.
Under bed mounting brackets with flanges facing out.

Put the rear brackets on row 3 for models 97 to current.
Put brackets on row 4 for models 96 and earlier.

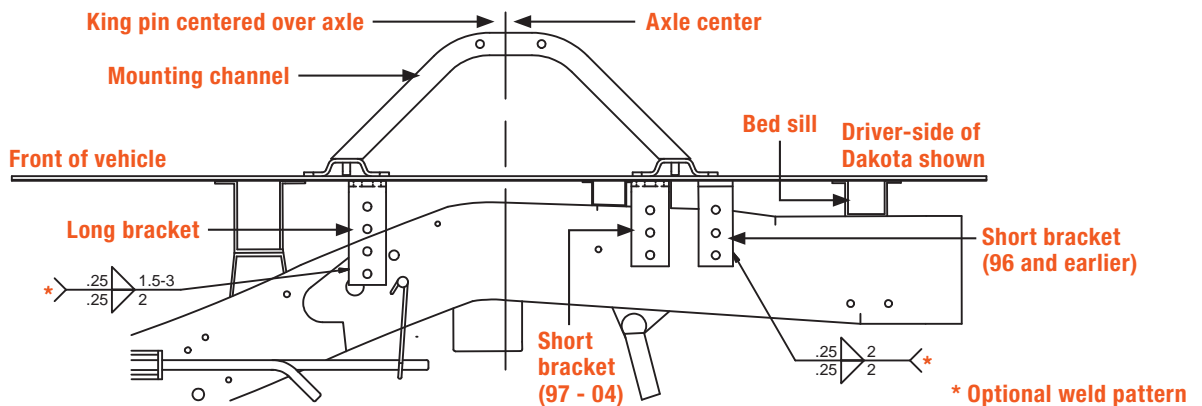
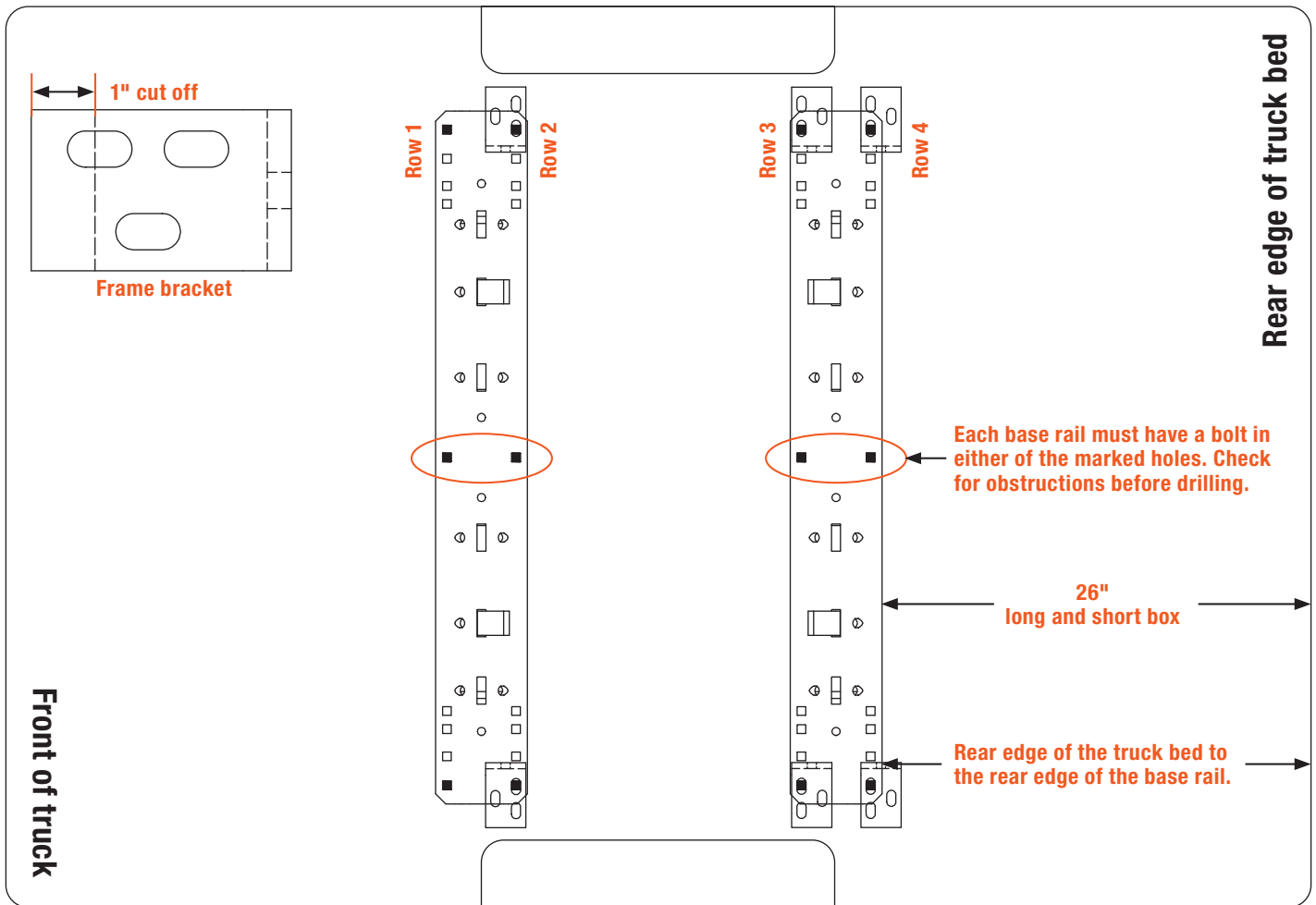

VEHICLE-SPECIFIC INSTALLATION

Toyota Tundra, standard cab 00 - 06 (long box only)

⚠ WARNING

Read pages 2 - 4 of this installation manual before beginning the installation. Failure to do so could result in significant vehicle damage.

Check for obstructions prior to drilling. Failure to do so could result in damaged fuel or brake lines, structural members, etc.

CURT does its best to communicate tow vehicle manufacturer changes. However, it is ultimately the responsibility of the installer to prevent damage due to installation.

IMPORTANT NOTES

Part #16302 spacer kit is required. Stack one 3/16" and one 5/16" slotted spacer, as required, to avoid crushing the truck bed.

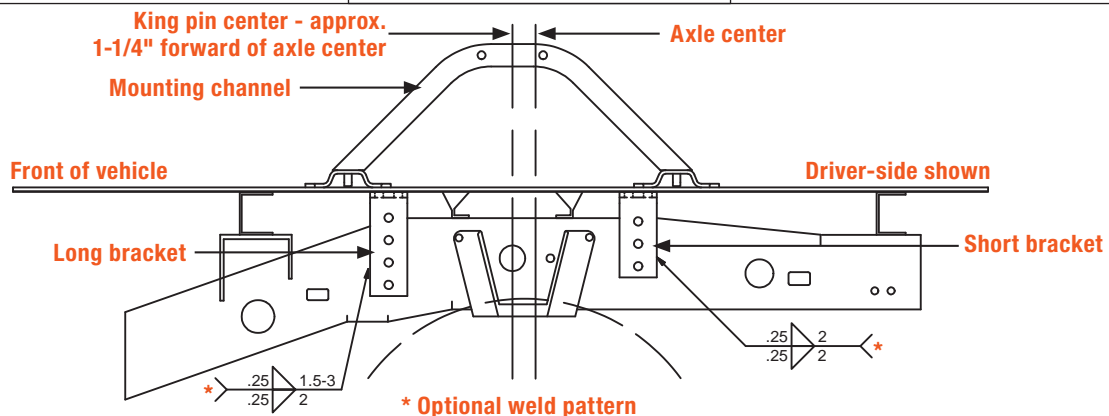
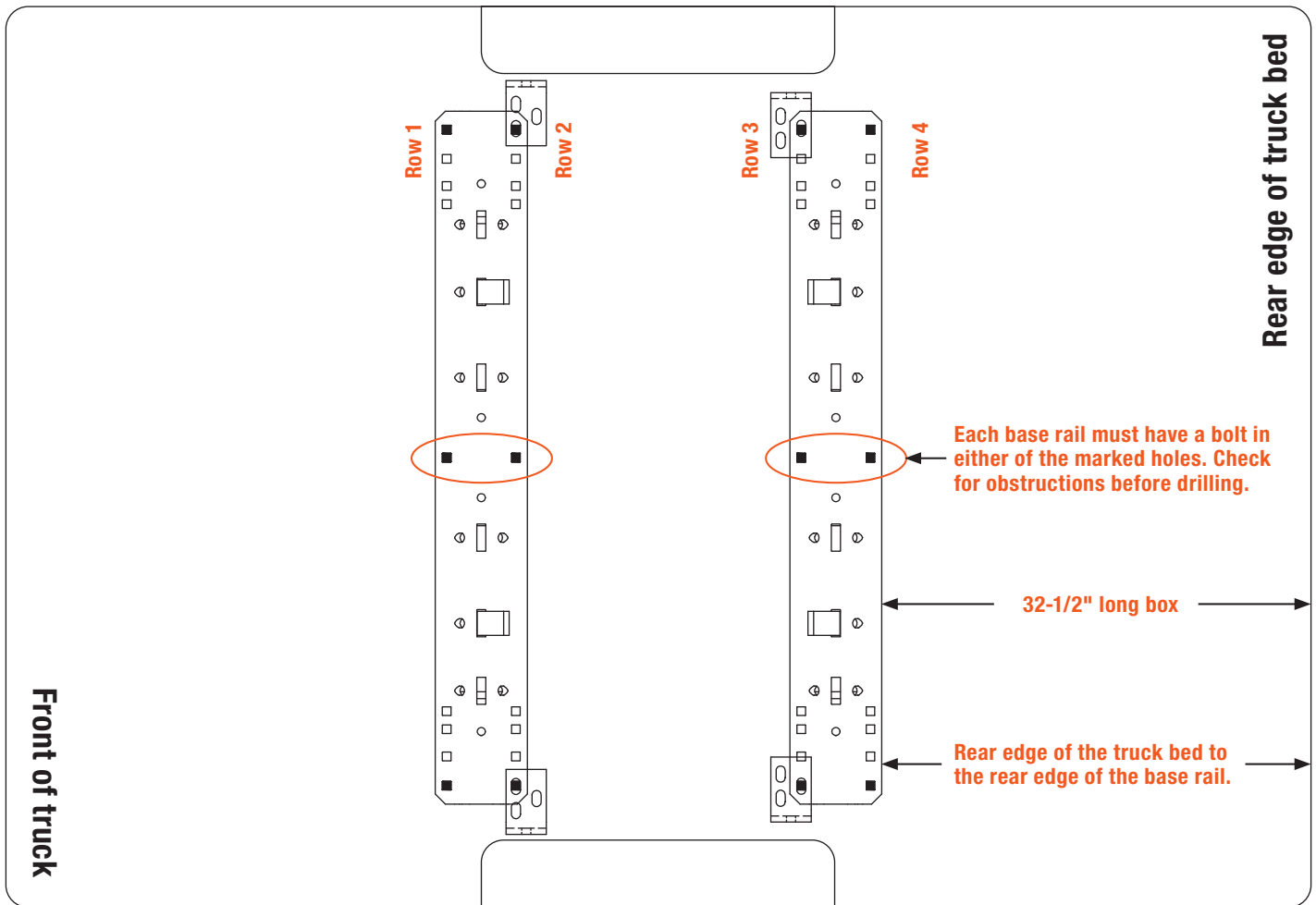

VEHICLE-SPECIFIC INSTALLATION

Toyota Tundra 07 - 08, excluding CrewMax (6.5' and 8' beds)

⚠ WARNING

Read pages 2 - 4 of this installation manual before beginning the installation. Failure to do so could result in significant vehicle damage.

Check for obstructions prior to drilling. Failure to do so could result in damaged fuel or brake lines, structural members, etc.

CURT does its best to communicate tow vehicle manufacturer changes. However, it is ultimately the responsibility of the installer to prevent damage due to installation.

IMPORTANT NOTES

Use the #16304 add-on kit with the #16100 universal kit.

The mounting holes for row 3 go through the inside of the bed sill. Make sure it lines up correctly. Drill through the bed and the top of the frame on both sides. For the row 4 passenger-side attachment, drill through the bed and top of the frame as well.

Notes continued in the illustration below

Additional Notes

The rear rail on the passenger side is secured directly to the frame with 3" carriage bolts provided in the #16304 kit.

For the row 3 attachment, a tube spacer should be placed inside the bed sill on top of the frame and under the bottom of the bed. Line up the spacer with the drilled hole before inserting the carriage bolt. Repeat for both sides. See figure 1.

For the row 4 passenger-side attachment, stack two 1/2" spacers and a beveled washer, provided in the #16304 kit, to fill the gap between the bed and the frame. Use another beveled washer, conical toothed washer, and hex nut to fasten the 3" carriage bolt in place. See figure 1.

Install the long brackets on the front base rail and the short bracket on the rear driver-side base rail using the 1-3/4" carriage bolts provided in the #16304 kit. All other attachments to the bed use 2" carriage bolts from the #16100 base rail kit.

