

INSTALLATION INSTRUCTIONS

WARNING: NEVER EXCEED YOUR VEHICLE MANUFACTURER'S RECOMMENDED TOWING CAPACITY

RAM OEM COMPATIBLE 5TH WHEEL LEGS

Provide this manual, in its entirety, to the end-user



PARTS LIST

Item#	Qty	Description
1	1	Passenger side leg assembly
2	1	Driver side leg assembly
3	1	Cross support weldment
4	2	Hex head cap screw, M14 x 75, CL8.8
5	2	Washer, flat, M14
6	2	Washer, lock, M14
7	4	Nulock nut, M14 x 2, CL10.9

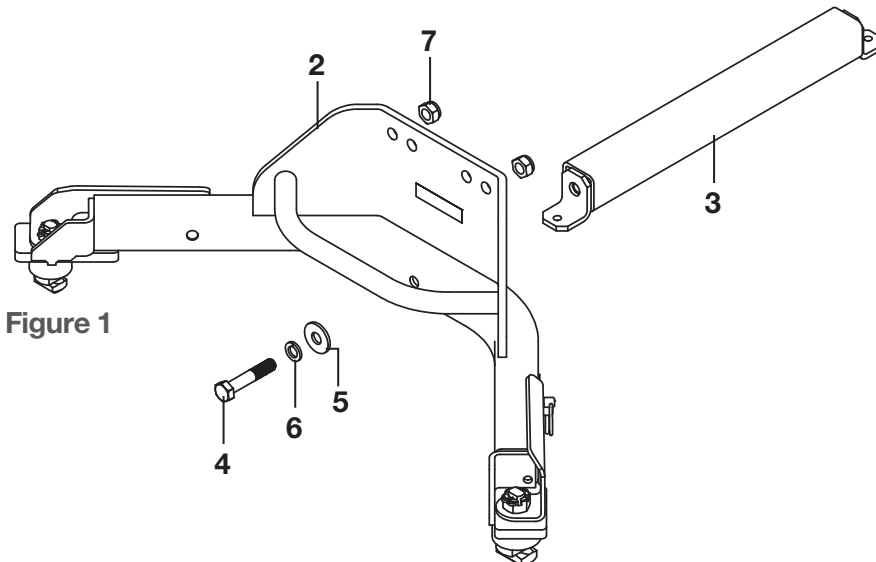
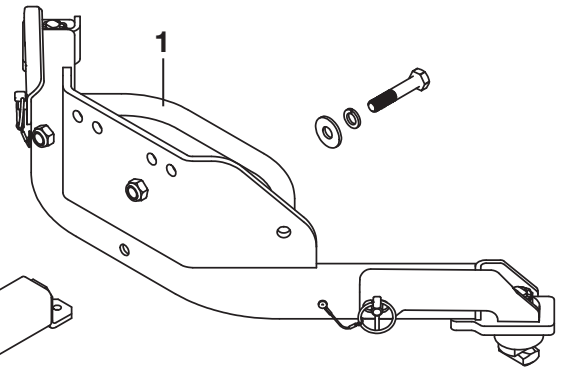

Figure 1

WARNINGS

Provide this manual, in its entirety, to the end-user. Read and understand instructions before using this product. Fully instruct and demonstrate the operation of this 5th wheel hitch to the end user. Include the importance of observing all warnings contained herein, including warning labels on 5th wheel hitch mid section. Serious injury or death may result if the warnings below are not observed.

To avoid serious injury, do not expose hands, body parts or clothing between the truck and trailer or the truck's bed sides and trailer. Extreme care should be observed to avoid serious injury to self, property and observers.

Never exceed the rated towing capacity of the tow vehicle. Trailer and contents combined must not exceed tow vehicle, hitch and / or trailer tow ratings. Exceeding rated capacity may result in separation and / or may result in damage to 5th wheel hitch, towing vehicle, trailer or cause death or serious injury.

Never position yourself or others under the trailer's kingpin area (danger zone) during coupling and uncoupling. Improperly coupled trailers can separate and drop without notice.

ASSEMBLY

Step 1

Prepare the 5th wheel head unit for installation by locating the hardware package containing four M14 hex bolts and flat washers. The 16021 RAM OEM legs are compatible with the following CURT 5th wheel heads: 16520, 16545, 16530, 16515.

Step 2

Select a set of mounting holes that will allow sufficient clearance between the 5th wheel trailer and the sides of the tow vehicle. Begin assembling the legs to the 5th wheel hitch head using the M14 bolts and M14 washers (provided with 5th wheel head unit) through the selected mounting holes and loosely secure them with the nylock nuts (#7) provided in the 16021 hardware kit.

NOTE: Position the leg assembly with the operating instruction label on the driver side of the tow vehicle. The large locking feet on the 16021 will match the large rear mounts in the truck bed.

Figure 2

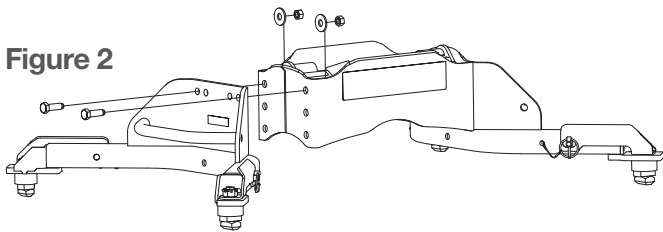

Step 3

With the legs in position, locate the cross support weldment (#3). Loosely attach the cross support between the two leg assemblies (#1, #2) with the provided M14 x 75 hex bolts (#4), lock washers (#6) and flat washers (#5). See Figure 3.

ASSEMBLY (CONT)

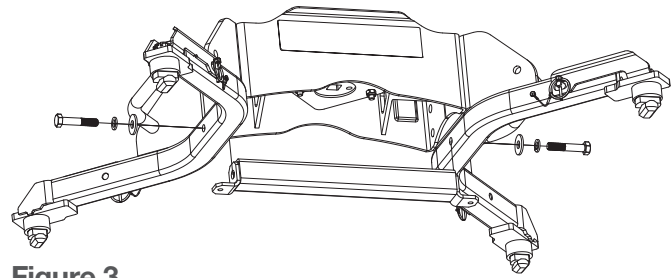

Figure 3

Step 4

Remove the four lynch pins securing the locking handles to the legs. Swing all four handles completely open and lower the legs into position in the bed of the truck. Ensure all four locking bolts and spacers drop into the mounting holes before attempting to close the handles. See Figure 4.

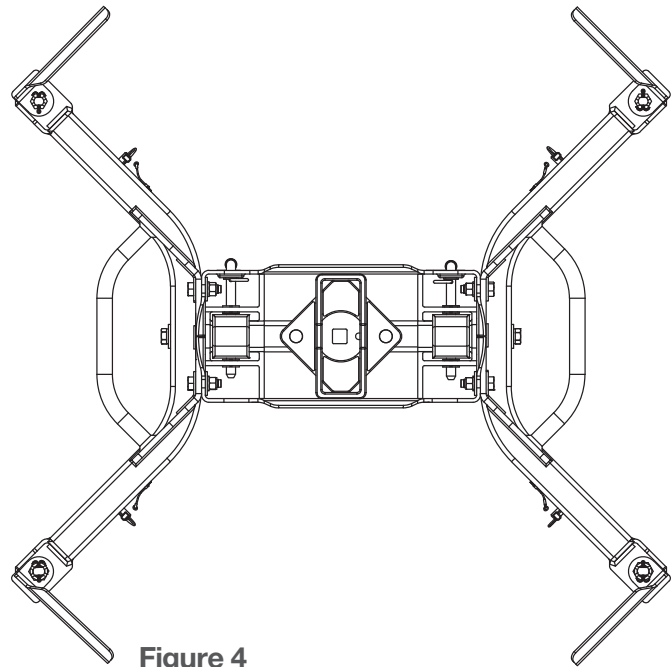

Figure 4

Step 5

With the 16021 in position, torque all six M14 bolts to 100 ft-lbs. Re-install the 5th wheel head if it was removed to ease installation.

Step 6

With the legs secured and positioned in truck bed mounts, rotate the handles back to the closed position. Secure the handles by re-inserting all four lynch pins. **NOTE:** Slight resistance should be felt as the handles are rotated closed. If the handle will not close with moderate pressure, adjustments must be made to the locking T-bolt; see 'T-bolt Adjustment'.

WARNING: Forcing the handle closed may damage the locking bolt and handle, possibly resulting in trailer detachment.

Step 7

Confirm all four locking bolts are engaged in the truck bed mounts and the castle nuts are secured with the cotter pins. Finally, double check to ensure all four handles are securely locked with the lynch pins. The 16021 is now installed and ready for use.

T-BOLT ADJUSTMENT

Step 1

The locking T-bolts have been pre-installed to ease installation of the 16021. Due to possible variation in the trucks mounting locations, some adjustments may be required. If one or more of the locking handles will not close, begin adjustment by removing the cotter pin securing the castle nut above the handle. See Figure 5.

Step 2

Loosen the castle nut a quarter-turn while pressing down on the T-bolt.

Step 3

Reattempt to close the locking handle. If the handle closes, resecure the castle nut with the removed cotter pin from Step 1. If the handle does not close, repeat Step 2.

