

INSTALLATION INSTRUCTIONS

WARNING: NEVER EXCEED YOUR VEHICLE MANUFACTURER'S RECOMMENDED TOWING CAPACITY

FORD OEM COMPATIBLE 5TH WHEEL LEGS

Provide this manual, in its entirety, to the end-user



PARTS LIST

Item#	Qty	Description
1	2	Leg weldment
2	4	Bolt, locking
3	2	Handle, left
4	2	Handle, right
5	4	Flat washer
6	4	Castle nut
7	4	Puck
8	2	Safety pin, 3/8" x 1 3/4" long
9	4	Cotter pin

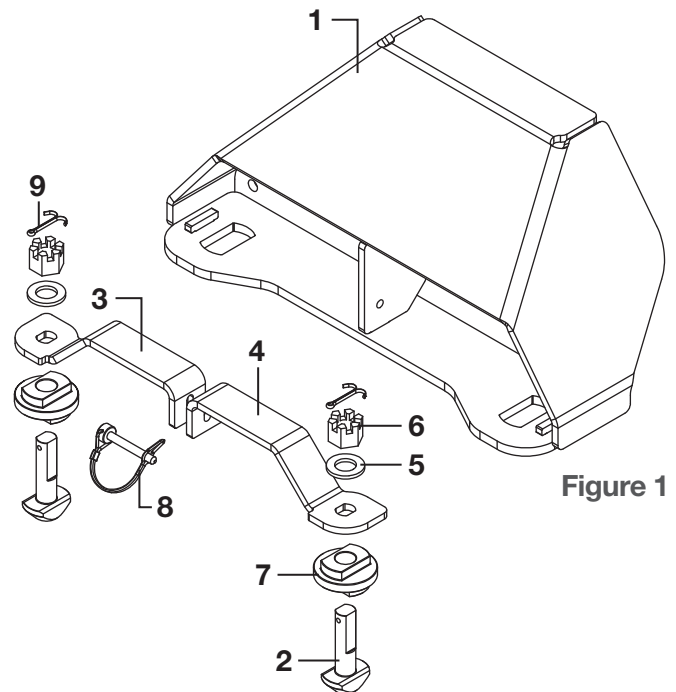

Figure 1

WARNINGS

Provide this manual in its entirety to the end-user. Read and understand instructions before using this product. Fully instruct and demonstrate the operation of this 5th wheel hitch to the end user. Include the importance of observing all warnings contained herein, including warning labels on 5th wheel hitch mid section. Serious injury or death may result if the warnings above are not observed.

To avoid serious injury, do not expose hands, body parts or clothing between the truck and trailer or the truck's bed sides and trailer. Extreme care should be observed to avoid serious injury to self, property and observers.

Never exceed the rated towing capacity of your vehicle. Trailer and contents combined must not exceed tow vehicle, hitch and/or trailer tow ratings. Exceeding rated capacity may result in separation. Exceeding rated capacity may result in damage to 5th wheel hitch, towing vehicle, trailer and or cause serious injury or death.

Never position yourself or others under the trailer's kingpin area (danger zone) during coupling and uncoupling. Improperly coupled trailers can separate and drop without notice.

ASSEMBLY

Step 1

Remove the latch pin securing the lock handles in the closed position and open the handles 90°.

Step 2

Remove all four cotter pins securing the castle nuts. Loosen the castle nuts until you can achieve a minimum of a 1/8" clearance between the lock bolt and the bottom surface of the puck.

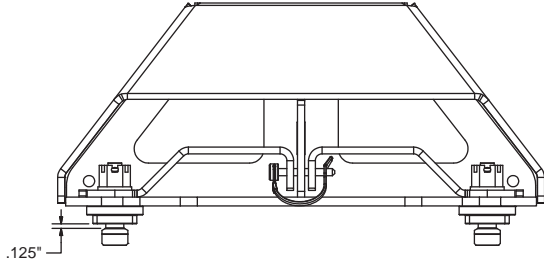

Figure 2

Step 3

Assemble the legs loosely to 5th wheel head using the 14mm hardware provided with the hitch and lower the assembly onto the factory mount position in the truck bed.

Step 4

With the hitch in position, finish securing the legs to the head by tightening the bolts from step 3 to 100 ft-lbs.

Step 5

Adjust the castle nuts tension until the locking bolt (#2) is snug when handles (#3, #4) are rotated to the lock position. Do not over tighten the castle nuts. The handles should close with moderate hand pressure only. Forcing the handles to the closed position will strip the handles and result in hitch failure.

Step 6

With the castle nuts adjusted to the proper height for each lock handle, re-install the cotter pins removed in step 1.

Step 7

Close all four locking handles and secure them using the provided safety pins (#8).